

# CITY OF RIPON

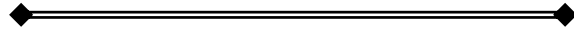

## STANDARD SPECIFICATIONS

AND

## STANDARD DETAILS



**CITY OF RIPON**  
**STANDARD SPECIFICATIONS AND STANDARD DETAILS**

**INTRODUCTION**

The purpose of these Standards is to provide certain minimum requirements to be used in the design and drawing of plans for public improvements such as street work, sanitary sewers, water lines, and storm sewers. It makes reference to, and is to be used in conjunction with the latest Standard Specifications of the State of California (Caltrans). It is intended to serve as a guide in the preparation of contract drawings.

The following standards generally represent minimum values. The word "minimum" implies the lowest acceptable limit in design.

These standards intend to cover only normal situations encountered in design. It can be expected that many engineering problems will arise which will not be completely covered. Therefore, any items or situation not included shall be designed in accordance with accepted engineering practice, the Caltrans Standard Specifications, or as directed by the Ripon City Engineer.

The General Conditions stated herein are written as they shall apply for projects on which the City of Ripon is the Owner, although they may be utilized on other projects in which the City is not the Owner.

***Latest Edition***  
April 16, 2007

# CITY OF RIPON STANDARD SPECIFICATIONS

## TABLE OF CONTENTS

<b>SECTION</b>	<b>DESCRIPTION</b>	<b>PAGE</b>
<b>10-00</b>	<b>TRENCHING AND BACKFILLING.....</b>	<b>1</b>
10-01	TRENCHING.....	1
10-02	DEWATERING OF TRENCH.....	2
10-03	BACKFILLING IN AREAS WITHIN STREET RIGHTS-OF-WAY.....	2
10-04	BACKFILLING IN AREAS NOT WITHIN STREET RIGHTS-OF-WAY....	3
10-05	REPLACEMENT OF PAVING.....	4
10-06	RELATIVE COMPACTION TESTING.....	4
<b>11-00</b>	<b>STORM SEWER CONSTRUCTION.....</b>	<b>5</b>
11-01	MATERIAL.....	5
11-02	PIPE INSTALLATION.....	7
11-03	CAST-IN-PLACE CONCRETE PIPE.....	7
<b>12-00</b>	<b>SANITARY SEWER CONSTRUCTION.....</b>	<b>12</b>
12-01	MATERIAL.....	12
12-02	INSTALLATION OF PIPE.....	16
12-03	SERVICE CONNECTIONS.....	17
12-04	INFILTRATION ALLOWANCE.....	18
12-05	TESTING.....	18
12-06	BACKFILLING.....	19
12-07	TELEVISIONING OF SANITARY SEWER.....	19
<b>13-00</b>	<b>CURB, GUTTER AND SIDEWALK CONSTRUCTION.....</b>	<b>21</b>
13-01	MATERIALS.....	21
13-02	OBSTACLES.....	22
13-03	GRADING.....	22
13-04	SETTING FORMS.....	22
13-05	CONCRETE.....	22
13-06	TESTING FLOW LINES.....	23
13-07	CURING.....	23
13-08	TOLERANCE.....	23
13-09	BACKFILL.....	23
13-10	CUTTING EXISTING PAVEMENT SURFACE.....	23
<b>14-00</b>	<b>STREET CONSTRUCTION.....</b>	<b>24</b>
14-01	MATERIAL.....	24
14-02	SUBGRADE.....	24

14-03	PLACING OF SUBBASE AND BASE COURSE .....	24
14-04	PLACING PRIME COAT OR PAINT BINDER.....	24
14-05	PLACING OF PAVEMENT.....	25
14-06	WATER FOR USE ON THE JOB.....	25
14-07	DUST CONTROL.....	25
14-08	SEAL COAT (RUBBER LATEX) .....	25
14-09	DESIGN PARAMETERS FOR ALL NEW STREETS .....	25
<b>15-00</b>	<b>WATER DISTRIBUTION SYSTEM.....</b>	<b>26</b>
15-01	MATERIAL .....	26
15-02	PIPE INSTALLATION .....	30
15-03	TESTS AND TOLERANCES.....	31
15-04	THRUST BLOCKS.....	31
15-05	DISINFECTION OF SYSTEM.....	31
15-06	FIRE HYDRANTS .....	32
15-07	BACKFILLING.....	33
15-08	TRACER WIRE .....	33
<b>16-00</b>	<b>NONPOTABLE WATER SYSTEM .....</b>	<b>34</b>
16-01	INTRODUCTION.....	34
16-02	TRANSMISSION / DISTRIBUTION LINES .....	34
16-03	CANAL WATER .....	35
16-04	PUMPING .....	35
16-05	ON-SITE APPLICATIONS.....	36
16-06	SYSTEM MANAGEMENT.....	41
<b>17-00</b>	<b>STORM WATER POLLUTION PREVENTION .....</b>	<b>46</b>
17-01	NOTICE OF INTENT, WDID, AND SWPPP.....	46
17-02	STORM DRAIN INLET PROTECTION .....	46
17-03	FIBER ROLLS.....	47
17-04	STABILIZED CONSTRUCTION ENTRANCE .....	47
17-05	CONCRETE WASHOUT AREAS.....	48
17-06	STREET SWEEPING AND VACUUMING .....	48
17-07	PORTA POTTY LOCATIONS .....	49
17-08	SILT FENCING	
<b>APPENDIX A</b>	<b>.....</b>	<b>50</b>
<b>APPENDIX B</b>	<b>.....</b>	<b>53</b>
B-01	GENERAL.....	53
B-02	PRELIMINARY INVESTIGATION .....	53
B-03	SERVICE APPLICATION.....	53
B-04	CONTROL OF DESIGN.....	54
B-05	EXAMPLE DESIGN AND INSPECTION CONTROL PROCEDURES ..	55
B-06	GRANTING OF EASEMENT TO THE CITY .....	57
B-07	DEDICATION OF OFF-SITE FACILITIES TO CITY.....	57
B-08	GUARANTEES .....	57
B-09	ISSUING OF USER PERMIT (SERVICE AGREEMENT) .....	57
B-10	ESTABLISHING SERVICE CONNECTIONS.....	57
B-11	SERVICE START UP.....	57

# ***CITY OF RIPON STANDARD SPECIFICATIONS***

## **DETAILED SPECIFICATIONS**

### **10-00 TRENCHING AND BACKFILLING**

#### **10-01 TRENCHING**

**10-01a Excavation:** The excavating of the trenches shall include the removal of all earth, rock, stone, concrete, pavement, and all other surface and underground materials and obstructions encountered. All trenches shall be excavated true to the line and grade shown on the Plans and as established by the Engineer. Trenches shall be excavated to a width of one and two tenths (1.2) times the external diameter of the pipe to be laid therein plus twelve (12) inches.

**10-01b Grading:** The bottom of the trench shall be graded to the exact grade and shape as shown on the Plan and established by the Engineer. The methods to be used by the Contractor to transfer the grades from the point established by the Engineer to the bottom of the trench shall meet the approval of the Engineer.

Cross-cuts or bell holes of sufficient size and depth shall be excavated across the trench in such positions and at such location that the pipe will not rest upon any part of the bell or coupling at the joint. The pipe shall be supported uniformly along the entire length of the pipe between the bells or couplings. Cross-cut or bell holes shall not be excavated for more than six (6) joint lengths ahead of pipe laying.

**10-01c Safety:** All trenching shall be excavated in accordance with the latest revisions of the Trench Construction Safety Orders of the State of California, Department of Industrial Accident Commission, and shall be shored and braced when necessary.

**10-01d Unstable Material in Trenches:** Where mud, sand, peat or any other unstable material is encountered at or within three (3) inches of the bottom grade of any trench, such unstable material shall be removed to a depth of at least six (6) inches below the established grade and the trench brought to the established grade by the placing and thoroughly tamping in place a material suitable to the Engineer.

**10-01e Utilities:** All utility lines, conduits or structures encountered in, across or near the trench excavation shall be properly protected and supported during trench excavation. The Contractor shall be responsible for any damage or injury to such pipes, conduits or structures and shall replace and/or repair at his own expense any such damage or injury using like materials as approved by the Engineer.

**10-01f Neat Lines of Trench:** Excavation inadvertently carried below the established grade shall be brought to the established grade by the placing and compacting of suitable materials as approved by the Engineer.

**10-01g Transfer of Grades:** The methods to be used by the Contractor to transfer the grades from the control points established by the Engineer to the bottom of the trench shall meet the approval of the Engineer.

**10-01h Pavement Saw Cut:** All pavement removals shall be made on straight line saw cuts a minimum of 1-1/2 inches deep. If proposed cut line is less than three feet from an existing cut line, expansion joint or edge, the existing pavement shall be removed to cut lines, expansion joint or edge or as directed by the City Engineer.

## **10-02 DEWATERING OF TRENCH**

**10-02a Determining Water Table Height:** The Contractor shall first visit the site of the work and satisfy himself and the Engineer as to the position of the existing groundwater table. If, in the opinion of the Engineer, the groundwater table lies at an elevation high enough for interference with the laying of pipe, the Contractor shall, prior to the actual digging of the trench, dewater the area involved.

**10-02b Methods:** The dewatering of the area shall be accomplished by the installation of shallow wells with portable pumping units or alternate methods for wet ground construction which maintain a dry work area. These wells shall be at such depths as to drain the lowest point of the proposed line and shall be spaced along the line in sufficient number to insure a dry trench. All proposed methods must be submitted to the City Engineer for approval.

## **10-03 BACKFILLING IN AREAS WITHIN STREET RIGHTS-OF-WAY**

**10-03a Backfill Over Pipes:** No backfilling shall be done prior to the approval of the Engineer. Partial backfilling shall be done by hand, using extreme care not to disturb the line or grade of the pipe. The material for this initial backfill shall be selected from the finest earth in the excavated materials. The initial backfill shall be placed and thoroughly tamped equally on both sides of the pipe in equal depths, as approved by the Engineer to a relative compaction equal to 90%. Method for determining relative compaction shall be based upon ASTM dry density method.

The backfill from a point three (3) feet below subgrade to subgrade shall be placed in accordance with Section 19-3.06, of California Standard Specifications and the relative compaction shall not be less than 95%, but the lifts may be greater than eight (8) inches, provided that compaction methods proposed by the Contractor are approved by the Engineer.

In deep trenches, the backfill from a point one (1) foot above the top of the pipe to a point three (3) feet below subgrade may be placed and compacted by flooding (must have recommendation by a geotechnical consultant) with water in layers not exceeding two (2) feet in depth. The material comprising this backfill shall have a minimum relative compaction of 90%. No jetting.

**10-03b Structures:** Backfill around manholes, lampholes and other structures shall be a homogeneous mass of material uniformly distributed around all parts of the structures. The bottom portion of the backfill shall be placed and thoroughly tamped equally on all sides of the structure in equal depths, as approved by the Engineer, or flooded with water in layers not exceeding two (2) feet, to a point three (3) feet below subgrade. This material comprising the backfill of the bottom portion shall be of relative compaction equal to that of the undisturbed soil adjacent to the areas to be backfilled. The backfill from a point three (3) feet below subgrade to subgrade shall be placed in accordance with Section 19-03.06, of California Standard Specifications and the relative compaction shall not be less than 95%, but the lifts may be greater than eight (8) inches, provided that compaction methods proposed by the Contractor are approved by the Engineer.

**10-03c Unstable Materials:** When native material, in the opinion of the Engineer, is unsuitable for use as backfill, it shall be disposed of as directed by the Engineer and suitable imported material approved by the Engineer shall be furnished by the Contractor for the backfill.

#### **10-04 BACKFILLING IN AREAS NOT WITHIN STREET RIGHTS-OF-WAY**

**10-04a Backfill Over Pipes:** No backfilling shall be done prior to the approval of the Engineer. Partial backfilling shall be done by hand, using extreme care not to disturb the line or grade of the pipe. The material for this initial backfill and the compaction procedure shall be the same as the mentioned in Section 10-03a for initial backfill for pipes within street rights-of-way.

The remaining backfill may be placed and compacted by flooding or jetting with water in layers not exceeding two (2) feet in depth. The material comprising this backfill shall have the same relative compaction as the undisturbed soil adjacent to the area to be backfilled.

**10-04b Structures:** Backfill around manholes and other structures shall be a homogeneous mass of material uniformly distributed around all parts of the structure. The backfill shall be placed and thoroughly tamped equally on all sides of the structure in equal depths, as approved by the Engineer, or flooded with water in layers not exceeding two (2) feet in depth. This backfill shall be of a relative compaction equal to that of the undisturbed soil adjacent to the areas to be backfilled.

## **10-05 REPLACEMENT OF PAVING**

Whenever pavement is removed in the installation of utility lines and appurtenant structures within City streets, the pavement shall be replaced, after proper backfilling, with a minimum of six (6) inch thick asphalt concrete surface. Base rock will be required equal to that which exists at the trench cut. Driveways or other surfaced areas shall be resurfaced with a material of equal quality and of equal thickness to that which exists.

## **10-06 RELATIVE COMPACTION TESTING**

ASTM D1557 (dry density) shall be used to determine the relative compaction of untreated and treated soils and aggregates.

This compaction method covers the determination of the relationship between the moisture content and density of soils and soil-aggregate mixtures.

California test 216F (Caltrans) is also acceptable for determination of the relative compaction of untreated and treated soils and aggregates.



## 11-00 STORM SEWER CONSTRUCTION

### 11-01 MATERIAL

#### 11-01a Pipe:

- (1) **Reinforced Concrete Pipe** - Reinforced concrete pipe shall conform to Caltrans Section 65 and shall be Class III, unless otherwise shown on the Plans.
- (2) **Cast-In-Place Concrete Pipe (Must have special approval of City Engineer)**- See Section 11-03 for material specification.
- (3) **Smooth Interior Corrugated Polyethylene Pipe (Must have special approval of City Engineer)**- This specification applies to high density polyethylene corrugated pipe with an integrally formed smooth waterway. Nominal sizes for which this specification is applicable are 4 - 48 inch diameter. Sizes 4 - 36 inch (N-12) shall have a full circular cross-section, with an outer corrugated pipe wall and an essentially smooth inner wall (waterway). Corrugations for these sizes may be either annular or spiral. Sizes 42 and 48 inch (N-12 HC) shall consist of an essentially smooth waterway braced circumferentially with circular ribs which are formed simultaneously with an essentially smooth outer wall. All sizes shall conform to the AASHTO classification "Type S" (which describes pipe with a smooth waterway).

Pipe manufactured for this specification shall comply with the requirements for test methods, dimensions, and markings found in AASHTO Designations M252 and M294'. Pipe and fittings shall be made from virgin PE compounds which conform with the requirements of cell class 324420C as defined and described in ASTM D3350.

The minimum parallel plate stiffness values when tested in accordance with ASTM D2412 shall be as follows:

<u>Diameter</u>	<u>Pipe Stiffness</u>
4" (100 Mm)	50 psi (340 kPa)
6" (150 mm)	50 psi (340 kPa)
8" (200 mm)	50 psi (340 kPa)
10" (250 mm)	50 psi (340 kPa)
12" (300 mm)	50 psi (340 kPa)
15" (375 mm)	42 psi (290 kPa)
24" (600 mm)	34 psi (240 kPa)
30" (750 mm)	28 psi (200 kPa)
36" (900 mm)	22 psi (1 50 kPa)

42" (1 050 MM)	419 psi (1 40 kPa)
48" (1200 mm)	17 psi (4 120 kPa)
18" (450 mm)	40 psi (280 kPa)

The fittings shall not reduce or impair the overall integrity or function of the pipe line. Fittings may be either molded or fabricated. Common corrugated fittings include in-line joint fittings, such as couplers and reducers, and branch or complimentary assembly fittings such as tees, wyes, and end caps. These fittings may be installed by various methods, such as snap-on, screw-on, bell and spigot, and wrap around. Couplings shall provide sufficient longitudinal strength to preserve pipe alignment and prevent separation at the joints. Only fittings supplied or recommended by the pipe manufacturer shall be used. Where designated on the plans, a neoprene or rubber gasket shall be supplied.

Installation of the pipe specified above shall be in accordance with CALTRANS Section 64 and ASTM Recommended Practice D2321. Also note that Class 2 AB bedding shall be used up to the spring line in all applications of this type of pipe.

All catch basin laterals are required to be 18" RGRCP. No exceptions will be made.

**11-01b Jointing Material for Concrete Pipe:** Cement, sand and water for jointing mortar shall conform to the requirements for these materials as specified in Section 90-2, California Standard Specifications. Cement mortar shall consist of one (1) part Portland Cement and two (2) parts sand. The consistency of the joint mortar shall be such that it will adhere readily to the pipe and can be easily squeezed out at the joints. All mortar shall be used within thirty (30) minutes after mixing with water, and all parts of the pipe to be in contact with the mortar shall be washed clean and thoroughly wetted to ensure proper bond.

**11-01c Concrete Material For Manholes and Catch basins:** The concrete material for manholes and catch basins shall conform to Class B Portland Cement Concrete with a one and one-half (1 ½) inch maximum combined aggregate grading produced and mixed in accordance with Sections 90-2 and 90-3, California Standard Specifications.

**11-01d Manhole Frame and Cover and Catch basin Frame:** The manholes and catch basin frames and cover shall conform to ASTM Specifications, Serial Designation A48-62 for Gray Cast Iron.

**11-01e Catch basin Grates:** All catch basin grates shall be steel black asphalt coated with chain and hot-dipped galvanized.

## **11-02 PIPE INSTALLATION**

**11-02a Laying Pipe:** Pipe laying shall begin at the lowest end of the trench and be laid up grade of the trench. The flow lines of all pipes shall be placed on the exact grade. Tongue and groove pipe shall be laid with the groove upstream. A shallow excavation shall be made underneath the pipe at the joint and the resulting space filled with mortar, into which the second pipe beds when laid. The groove end of the first pipe shall be thoroughly cleaned with a wet brush and a layer of soft mortar applied to the bottom half of the groove. The tongue end of the second pipe shall be thoroughly cleaned with a wet brush and while in a horizontal position, a layer of soft mortar shall be applied to the upper half of the tongue. The tongue end of the second pipe shall then be inserted into the groove end of the first pipe until the mortar is squeezed out on the interior and exterior surfaces. The interior surface of the pipe at the joint shall then be brushed smooth. Mortar shall then be placed around the joint forming an exterior band. As soon as the joint is inspected by the Engineer it shall be covered by damp earth to protect the fresh mortar.

**11-02b Manhole Installation:** Manholes shall be constructed of precast units, and of the dimensions shown on the Plans and shall be built or set true to line and grade. Wrought Iron Steps shall be installed in the manholes in the number and at the locations shown on the Plans. If no steps are shown on the Plans, steps shall not be required.

**11-02c Installation of Catch basins:** Before pouring any gutter around the catch basin, the exterior walls of the catch basin shall be thoroughly cleaned so the concrete of the gutter will securely bond to the catch basin.

## **11-03 CAST-IN-PLACE CONCRETE PIPE**

**11-03a Description:** Cast-in-place monolithic concrete pipe shall consist of Portland cement concrete placed in a prepared trench at the locations shown on the plans, as specified in these specifications and the special provisions, and as directed by the Engineer. All cast-in-place concrete pipe shall be constructed, tested, and inspected in accordance with the American Concrete Institute, sections ACI 346-90 and ACI 346R-90.

**11-03b Materials:** The pipe shall be constructed of Class A Portland cement concrete conforming to the provisions in Caltrans Section 90, "Portland Cement Concrete".

The combined aggregates for pipes 48 inches or less in diameter shall conform to the grading limits for the one inch, maximum size specified in Caltrans Section 90-3.04, "Combined Aggregate Gradings". For pipe larger than 48 inches in diameter, the combined aggregates shall conform to the grading limits for the 1 ½-inch, maximum size specified in the Caltrans Section 90-3.04.

Penetration shall not exceed 1 ½ inches when determined by California Test 533. The minimum wall thickness for the various sizes of pipe shall conform to the following table:

Internal Diameter	Wall Thickness
24" .....	3"
27" .....	3"
30" .....	3"
33" .....	3 ½"
36" .....	3 ½"
42" .....	4"
48" .....	5"
54" .....	5 ½"
60" .....	6"
66" .....	6 ½"
72" .....	7"
78" .....	7 ½"
84" .....	8"

**11-03c Pipe Making Equipment:** The pipe shall be constructed with equipment specially designed for constructing cast-in-place monolithic concrete pipe. The equipment shall be acceptable to the Engineer and the Contractor may be required to furnish evidence of successful operation on other work of the equipment he proposes to use. Equipment not

suitable to produce the quality of work required for the pipeline will not be permitted to operate on the work.

**11-03d Excavation:** Excavation shall conform to the provisions in Caltrans Section 19-3, "Structure Excavation and Backfill".

The trench shall be excavated to the lines and grades established by the Engineer. The finished trench invert area will be shaped to the external diameter of the pipe and be graded to provide a full firm uniform bearing throughout the bottom 180 degrees of the pipe. The trench width will not exceed the outside diameter of the pipe plus 2 inches to a height equal to the top of the pipe. The shape and size of trench must be maintained, if due to sandy or poor soil conditions the proper trench cannot be maintained, then this type of construction will not be permitted. For these unacceptable sections of trench pre-cast concrete pipe (RCP) must be substituted.

The trench will be kept free of rocks, mud, sloughed material, debris and water, standing or running. Any voids will be backfilled and compacted to 90% relative compaction.

**11-03e Construction:** All water, which may have entered the trench, shall be removed before constructing the pipe. All surfaces against which concrete is to be placed shall be free of standing water, mud, and debris.

Surfaces against which concrete is to be placed shall be thoroughly moistened with water, if necessary, so that moisture will not be drawn from the freshly placed concrete.

The concrete shall be placed around the full circumference of the pipe by means of traveling forms in one operation. When metal forms are used they shall be of sufficient strength to withstand vibrating or tamping the concrete and to permit workmen to walk on the forms without causing springing or bulging at any point.

The forms shall not vary more than 0.04-foot from the lower edge of a straightedge laid parallel to the center line of the form and shall be free of any holes larger than 0.05-foot in greatest dimension.

The concrete shall be vibrated, rammed, tamped or worked with suitable appliances until the concrete has been consolidated to the maximum practicable density, free of rock pockets, and closes snugly against all surfaces of forms. The concrete shall completely fill the form.

When placing operations cease for any reason, the end of the pipe shall be left rough with a slope of approximately 45 degrees, with 24 inch No. 4 dowels inserted one foot into the center of the pipe wall at approximately 18 inch intervals. The ends of the pipeline shall be covered with suitable material, to maintain a humid condition within the pipe.

Construction joints used for connections to another pipe or at junction structures will be made by squaring off the end of the pipe. An excavation will be made along the sides and bottom of the pipe to permit casting of the concrete collar. The collar will have a minimum thickness of 1-1/2 times the wall thickness, it shall have a length of 24 inches centered on the joint.

After the removal of forms, the inside of the pipe will be inspected and any required repairs shall be made. All porous and fractured concrete shall be removed by chipping openings into the concrete pipe as directed by the Engineer. The chipped openings and any holes cut in the pipe for inspection or to facilitate removing the forms shall be repaired by filling with concrete or dry patching mortar.

The contractor shall conform to all applicable occupational safety and health standards, rules, regulations and orders established by the State of California. See Standard Specification for Cast-In-Place Non-reinforced Concrete Pipe, Chapter 5 of ACI 346-90 for further detail.

The flow line grade of the finished pipe shall not vary more than 0.10-foot from the grade line established by the Engineer.

The finished surface of the concrete pipe shall be substantially free of fractures, cracks and roughness.

**11-03f Curing and Protecting Concrete:** The concrete forming the cast-in-place concrete pipe shall be cured by backfilling over the pipe or by backfilling over the pipe after application of either a waterproof membrane or a pigmented curing compound as provided in Caltrans Section 90-7, "Curing Concrete". Hand spraying of the compound will be permitted. During the period following the placement of the concrete, the ends of the pipeline shall be covered with suitable material to maintain a humid condition within the pipe for a minimum of 7 days.

If the Contractor elects to cure the pipe by backfilling without applying curing compound or membrane, the backfill material shall be placed to an approximate depth of one foot over the top of the pipe. If the Contractor elects to cure the pipe by backfilling after application of either curing compound or membrane, the backfill material shall be placed to an approximate depth of 0.5-foot over the top of the pipe. Under either method, such backfill shall be placed immediately after the concrete has hardened sufficiently to prevent injury to the pipe during backfilling operations. Only soft, damp, and loose material shall be used for backfill material.

The concrete pipe shall be protected as provided in Caltrans Section 90-8, "Protecting Concrete".

**11-03g Backfill:** Initial backfill shall be placed primarily to cure and protect the concrete, refer to ACI 346-90 Chapter 8. Total backfill may be placed 48 hours after the pour, yet it shall not be allowed to free fall, nor shall equipment be permitted on the pipe. Water jetting of the backfill shall be permitted after 72 hours. Mechanical compaction in lifts may be performed when the concrete has attained a strength of 2,250 psi.

**11-03h Testing:** The contractor shall be responsible for conducting the two following required tests: (1) All lines shall be televised in accordance with the City standard for testing sanitary sewer lines. (2) Hydrostatic test per the following specification:

No sooner than twenty-eight days after the PIPELINE has been installed or when the concrete has obtained a compressive strength of 2,500 psi, the pipeline shall be tested. The PIPELINE shall be tested between each control structure. Fill the PIPELINE with water (not less than 50 degrees F in temperature) to the maximum design head (street centerline elevation) or 7 feet of head whichever is greater. Maintain a full pipe for 48 hours. If leaks are evident, the line shall be drained and the leaks repaired by and at the expense of the Contractor. After the leaks have been repaired, refill the line to the aforementioned head and test for a minimum of 8 hours. During the test period, the leakage rate shall not exceed 750 gallons per inch of diameter per mile per 24 hours. If the line fails the hydrostatic test, the Contractor shall drain the line, repair all imperfections, and retest the line as described above.

**11-03i Measurement:** The length of cast-in-place concrete pipe to be paid for will be the slope length designated by the Engineer. Pipe placed in excess of the length designated will not be paid for.

**11-03j Payment:** The contract price paid per linear foot for cast-in-place concrete pipe shall include full compensation for furnishing all labor, materials, tools, equipment, and incidentals, and for doing all the work involved in constructing the pipeline, complete in place, including structure excavation and loose backfill as shown on the plans, and as specified in these specifications and in the special provisions, and as directed by the Engineer.

**11-04 Storm Drain Televising:** All storm drain pipelines shall be televised regardless of material type and shall be submitted in CD format.

## 12-00 SANITARY SEWER CONSTRUCTION

### 12-01 MATERIAL

#### 12-01a Pipe:

- (1) **Clay Sewer Pipe** - Vitrified clay pipe shall conform to the Specifications for extra strength pipe of A.S.T.M. Designation C-700 and C-301.
- (2) **Polyvinyl Chloride (PVC) Gravity Sewer Pipe** - Fittings shall be manufactured in accordance with A.S.T.M. D-3034, SDR--26 minimum wall thickness. The City Engineer may require special bedding standards. Depth and soil conditions will be taken into consideration.
- (3) **Cast Iron & Ductile Iron Pipe** - Cast iron pipe shall comply with ANSI A 21.6 (AWWA C106) for pipe cast in metal molds or ANSI A 21.8 (AWWA C108) for pipe cast in sand lined molds.

Ductile iron pipe shall comply with ANSI A 21.51 (AWWA C151).

**12-01b Fittings:** All wye branches and other fittings shall be of the same material and shall meet the same requirements as the pipe on which they are used. All wye branches shall be 45 degree angle and shall be capped.

#### 12-01c Joints:

- (1) **Vitrified Clay Pipe** - Either polyvinyl chloride or polyurethane compression joints may be used. Materials shall conform to A.S.T.M. Designation C-425.

Joints shall contain two sealing components, one bonded to the outside of the spigot and the other bonded to the inside of the socket. Sealing components shall be a plasticized polyvinyl chloride compound or polyurethane elastomer bonded to pipes and fittings at the pipe factory, and shall be cured to a uniform hardness and compressibility. The sealing components shall be shaped, sized, bonded, and cured in such a manner as to form a tight, dense, and homogeneous compression coupling when the joint is assembled. Any imperfection in the sealing components will be cause for rejection.

Upon installation, the mating surfaces shall be wiped clean of dirt and foreign matter, then an approved lubricant shall be applied to the joint surfaces. The spigot shall be positioned inside the socket and the joints shoved home. For large



diameter pipe, a lever attachment or bar cushioned with a wooden block shall be used to shove the joint into place.

In no case shall a bar be used on an unprotected joint surface. Mating surfaces shall be in tight contact with each other upon completion of the joint installation.

Polyvinyl chloride joints may be used on curves, provided that the radius of curvature is not less than shown in the following table, unless beveled pipe or shorter lengths are provided:

Pipe Size, Inches	Maximum Pipe Length, Feet	Minimum Radius of Curvature, Feet	Maximum Deflection
6	5	100	2 00'
8	5	100	2 00'
8	6	115	2 00'
10	5	185	1 33'
10	6	220	1 33'
12	6	215	1 20'
12	6	260	1 20'
15	5	275	1 03'
15	6	330	1 03'

Polyurethane joints may be permitted for use on curves, provided that the radius of curvature is not less than shown in the following table, unless beveled pipe or shorter lengths are provided:

Pipe Size, Inches	Maximum Pipe Length, Feet	Minimum Radius of Curvature, Feet	Maximum Deflection
6	5	100	2 00'
8	5	100	2 00'
8	6	115	2 00'
10	5	170	1 41'
10	6	205	1 41'
12	5	150	1 54'
12	6	180	1 54'
15	5	190	1 32'
15	6	225	1 32'
18	5	225	1 16'
18	6	275	1 16'

21	5	265	1 06'
21	6	315	1 06'
24	5	240	1 12'
24	6	290	1 12'
27	5	270	1 04'
27	6	325	1 04'
30	5	300	0 58'
30	6	360	0 58'
33	5	275	1 03'
33	6	330	1 03'
36	5	295	0 59'
36	6	355	0 59'
39	5	325	0 54'
39	6	385	0 54'
42	5	345	0 50'
42	6	415	0 50'

**(2) Polyvinyl Chloride Sewer Pipe -**

1. All joints shall be integral wall bell and spigot configuration, factory formed. All rubber rings shall conform to A.S.T.M. F-477.
2. Reducing wyes from service laterals shall be in line bell and spigot type, factory molded.
3. Assembly of all joints shall conform to A.S.T.M. P3212.
4. Saddle fittings for lateral connection will be permitted; solvent welded.
5. Manhole connections shall be by rubber ring water stop installed on pipe and cast in center of manhole wall or four (4) inches from outside face of manhole base. Pipe section on water stop at manhole shall have bell flush with outside of manhole or no more than ten (10) inches outside manhole.

**Deflection Test for PVC Sewer Pipe -** The Contractor shall furnish all equipment needed to complete this test. The cost for the deflection test shall be included in the unit price bid for the sanitary sewer pipe. Deflection test shall be conducted after the placement and densification of backfill.

Pipe Size & Type	Base I.D.	Allowable Deflection Based on Base I.D.
6" PVC	5.742	5½%
8" PVC	7.665	5%
10" PVC	9.563	5%
12" PVC	11.361	4½%
15" PVC	13.898	4%
18" PVC	16.976	4%

At the Contractor's expense, all locations with deflection greater than allowable shall be excavated, repaired or replaced, backfilled and retested.

**(3) Ductile Iron Pipe** - Ductile iron pipe joints shall comply with the following requirements for the types specified on the Plans.

<u>Type of Joint</u>	<u>Specification</u>
Rubber Gasket Push-on Joint	ANSI A21.11 (AWWA C111)
Mechanical Joint	ANSI A21.11 (AWWA C111)
Flanged Joint	ANSI B16.1, B.16.2 and A21.10 (AWWA C110)
Flanged Joint (Threaded Flanges)	ANSI B2.1.

All rubber gasket, push-on, mechanical and flanged joint fittings for ductile iron pipe shall be manufactured in accordance with ANSI A21.10 (AWWA C110).

**Slip-on Joint** - The gasket and gasket seal inside the socket shall be wiped clean before the gasket is inserted. A thin film of soft vegetable soap compound shall be applied to the gasket and the outside of the spigot end of the pipe. The spigot shall then be positioned inside the socket and shoved home. Lubricant other than that furnished with the pipe shall not be used unless approved by the Engineer.

**Mechanical Joints** - The outside of the spigot and the inside of the socket shall be thoroughly cleaned of foreign matter. The gland and gasket shall then be slipped onto the spigot end of the pipe. The gasket shall be pressed evenly into the socket only after the spigot is seated in the socket. The gland shall be brought up evenly by tightening alternately the nuts spaced 180 degrees apart. Bolts and nuts shall be coated with mastic following tightening.

**Flanged Joints** - Flanged joints shall be firmly and fully bolted with machine bolts of proper size. Full circle reinforced

neoprene rubber gaskets 1/16" thick shall be used at all flanged joints. Bolts and nuts shall be coated with mastic following tightening.

**12-01d Cement Mortar:** Cement mortar shall consist of two (2) parts sand and one (1) part cement. The mortar shall be used within thirty (30) minutes after the ingredients are mixed with water.

**12-01e Cement:** Cement for mortar and all other purposes shall be Type II Portland Cement in accordance with ASTM Serial Designation C-150-60.

**12-01f Sand:** Sand for mortar shall conform to the fine aggregate specifications of Section 90-2 of California Standard Specifications.

**12-01g Water:** Water for mixing mortar shall conform to Section 90-2 of California Standard Specifications.

**12-01h Concrete materials for Manholes, Main Line Cleanouts, and Encasements:** The concrete materials, the proportioning, the mixing and other requirements for the concrete shall be in accordance with Section 90-2 and Section 90-3 of the California Standard Specifications for Class B concrete with a 3/4 inch maximum combined aggregate mix.

**12-01i Manhole and Main Line Cleanout Frames and Covers:** Cast iron manhole and/or main line cleanout frames and covers shall be manufactured, tested and otherwise furnished in accordance with the Standard Specifications for Gray Iron Castings ASTM Serial Designation A-48-60. The contact surfaces of frames and covers shall be machined so as to produce a perfect contact around the entire seat.

**12-01j Markers:** Markers for wye branches on ends of house sewer laterals at property lines shall be ferrous metal stakes not less than twenty-four (24) inches long and being a flat or crimped bar not less than 1/4 inch thick by one (1) inch wide.

## **12-02 INSTALLATION OF PIPE**

**12-02a Handling of Pipe:** The pipe shall at all times during loading, unloading, moving and laying operation, be handled with care. Only methods of handling as approved by the Engineer shall be used in these operations. When using mechanical equipment, extreme care shall be used to avoid damage or scarring by placing of hooks, chains or other devices on the ends of the pipe.

**12-02b Cleaning of Pipe:** The inside of all couplings and the matched ends of all pipe to be coupled, and the inside of all pipe shall be free from dirt, grease or other deleterious material. The open ends of all pipe previously laid shall be adequately plugged whenever pipe laying operations are completed at the end of each work day or suspended for any reason.

**12-02c Grade and Alignment:** All pipe shall be laid true to the line and grade shown on the Plans. The methods used to transfer the grade from the control points established by the Engineer to the point of pipe laying in the trench shall be subject to the approval of the Engineer. The pipe shall not deviate from the established line for straight pipe alignment to the extent that a light placed in a lamphole or manhole cannot be clearly seen from the next adjacent manhole. For lines with curved alignment the deviation from the established line as determined by the Engineer before backfilling shall not exceed one-fourth (1/4) of the inside diameter of the pipe. The deviation from the established grade of the pipe shall not at any place exceed one-quarter (1/4) inch in any one length of pipe or at any point on the line.

**12-02d (1) Pipe Joints (Wedge-Lock or equal):** Before joining, each pipe shall be cleaned of all deleterious substances. The spigot shall be firmly pressed against the seat of the bell of the preceding pipe. The clay pipe and plastisol joint shall be protected against damage during the jointing operation.

**(2) Plain End Vitrified Clay Pipe:** Before joining, each pipe shall be cleaned of all deleterious substances, the coupling shall be placed on the end of the pipe section in place, the next pipe section brought into the coupling insuring that the rubber stop ring is in contact with both sections of pipe, the steel compression bands shall then be tightened sufficiently to make a watertight joint. The mortar sealant, if required, shall not be poured into the coupling housing before the sewer line has been tested for leakage.

**12-02e Encasements:** All wye branches, certain portions of lamphole structures, and other piping when shown on the Plans shall be encased in concrete of the dimensions shown on the Plans or in the Standard Details.

## **12-03 SERVICE CONNECTIONS**

The locations of all sewer services extended to the lot shall be marked by placing a sewer cleanout to the ground surface at the time of backfilling. Said end of service shall extend a maximum of fifty-four (54) inches and a minimum of forty-eight (48) inches beyond the rear edge of the sidewalk in streets having sidewalks adjacent to the curb and shall have a maximum of twelve (12) inches and a minimum of six (6) inches beyond the rear edge of sidewalks that are separated from the curb by a planter strip.

The location of every service shall be marked with an "S" directly above the service at the face of curb, the "S" to be one and one-half (1 ½) inches in height and one-quarter (1/4) inch in depth.

A clean out shall be installed on the sewer service at the rear edge of sidewalk or within the planter strip, as applicable (see Standard Drawings for installation details). Said clean out shall consist of a combination wye

and eighth bend riser, and clean out with plug. The property developer shall provide and install the clean out and box.

The location of every house sewer as measured from the next manhole downstream shall be stationed on the record drawings and delivered to the Engineer.

#### **12-04 INFILTRATION ALLOWANCE**

The allowable infiltration shall not exceed 100 gallons per inch of diameter, per mile of pipe, per 24 hours.

#### **12-05 TESTING**

Cleaning and testing shall be performed just prior to asphalt paving. Before sewer lines are accepted, they shall be cleaned with a Wayne Sewer Cleaning Ball, or approved equal, and all stoppage of foreign matter shall be removed by the Contractor.

Upon completion of cleaning, sewer lines shall be tested by either of the methods as outlined below.

**12-05a Water Test:** The section or sections of the pipe to be tested shall be selected by the Engineer. If, in any section tested, the leakage exceeds 200 gallons per inch of diameter, per mile of pipe, per 24 hours, all pipe shall be tested and leakage corrected at the expense of the Contractor.

The leakage test shall consist of plugging off the particular section between manholes and filling the section with water to a point in the upper manhole four (4) feet above the invert grade at the midpoint of the section being tested. After the water has stood four (4) hours, the water level will be recorded by the Engineer. After and additional two (2) hours, the water level will again be checked by the Engineer, who will calculate the leakage.

Branch sewers shall be plugged at their upper end if the test head would cause them to overflow.

Upon completion of the test, the test plugs in the sewer shall be removed.

Water for the above tests will be furnished by the City of Ripon, at points to be designated by the Engineer. If trucking is necessary, it shall be furnished by the Contractor.

**12-05b Air Tests:** The section of pipe to be tested shall be isolated by completely blocking all outlets in the section under test. Careful attention must be given to the bracing of all plugs, as the line will be under pressure. One of the plugs used at the manhole must be equipped for an air inlet to fill the line from the air compressor. The air compressor which feeds air into the pipe section must be equipped to control the air entry rate and to prevent the pressure from exceeding 5.0 pounds per square inch. The air

compressor shall be fitted with a blow-off valve set to operate a 5.0 pounds per square inch to prevent an increase in pressure which would be hazardous to the pipe line.

After the pipe has been wetted, the air shall be allowed to slowly fill the pipe line until a constant pressure of 4.0 pounds per square inch is maintained. At this point, the air compressor shall be controlled so that the internal pressure in the line is maintained between 4.0 and 3.5 pounds per square inch for at least two (2) minutes to permit the temperature of the entering air to equalize with the temperature of the pipe wall. During the two-minute stabilization period, all of the plugs and exposed fittings shall be checked for tightness with a soap solution. If leakage is found at such points, the pressure in the line should be released, and the plugs tightened to stop the leakage. If it is necessary to bleed off the air to repair a faulty plug, a new two-minute interval must be allowed when the line has been refilled.

When the temperature of the air has reached equilibrium with that of the pipe wall, the air source shall be disconnected. Before disconnecting the air supply, the pressure shall be at 4.0 pounds per square inch. The gauge is then watched until the air pressure reaches 3.5 pounds per square inch. When the pressure has reached 3.5, a stop watch will be started and stopped when the pressure has reached 2.5 pounds per square inch. The time required, as shown on the watch, for the loss of 1.0 pounds per square inch at an average pressure of 3.0 pounds per square inch, is used to calculate the rate of air loss.

The pipe line may be considered to have passed the air loss test successfully if the loss of air is not greater than a rate of 0.0030 cubic feet per minute per square foot of internal pipe surface. For any reach of sewer being tested, the line is also acceptable when the loss of air is greater than 0.0030 cubic feet per minute per square foot of internal pipe surface, but the total rate of air loss from the entire section does not exceed two (2) cubic feet per minute.

The Contractor shall furnish all equipment needed to complete this test. The cost for the air test shall be included in the unit price bid for the sewer pipe.

#### **12-06 BACKFILLING**

Backfilling shall be done as specified in Sections 10-03 and 10-04 as applicable.

#### **12-07 TELEVISIONING OF SANITARY SEWER**

Following the placement and compaction of backfill and completion of other required testing, but just prior to the placing of pavement, the Contractor shall televise all sewer lines for conformance to the Plans and Specifications. A CD of the televising shall be delivered to the Engineer

within a week of televising. If defective pipes or conditions are discovered, they shall be corrected at no cost to the City. Any corrective work proposed shall be approved by the Engineer.

The City may also televise sewer lines prior to the expiration of the one year warranty. If a defective condition is subsequently found, it shall be presumed to be caused by defective workmanship or materials. The Developer and/or Contractor shall be notified and shall correct the work in a manner approved by the Engineer.

**12-07a Defective work includes, but is not limited to:**

1. Cracks or breaks in the pipe.
2. Joints offset more than 3/8" or 1% of the inside diameter, whichever is greater.
3. Protruding, folded or otherwise deformed gaskets.
4. Standing water exceeding the following (based on loss of 10% of the pipe area):

6" dia.	1"
8" dia.	1-1/8"
10" dia.	1-1/2"
12" dia.	1-3/4"
15" dia.	2-1/8"
18" dia.	2-5/8"



## **13-00 CURB, GUTTER AND SIDEWALK CONSTRUCTION**

### **13-01 MATERIALS**

**13-01a Forms:** The forms may be either wood or metal. The forms shall be equal in depth to the full depth of the concrete to be poured adjacent to the forms above subgrade.

**13-01b Expansion Joint Material:** The expansion joint material shall consist of made-up felt walls with an asphaltic filler conforming to ASTM Serial Designation D1751-60T and shall not be less than 3/8 inch or greater than 1/2 inch in thickness. The joint material shall be of sufficient depth and width to extend entirely through the concrete work involved.

**13-01c Concrete Materials:** The concrete shall be Class B Portland Cement Concrete made with one and one-half (1 1/2) inch maximum grading, in accordance with Section 90-3.04, California Standard Specifications. Only enough water shall be added to produce a workable plastic mix and in no case shall the slump exceed three (3) inches when measured by the Standard ASTM method C143-58. One (1) pound of lamp black per cubic yard of concrete shall be added to the concrete to produce a uniform gray color.

**13-01d Dowel Bars:** Dowel bars shall consist of 5/8" x 24" plain steel bars manufactured in accordance with ASTM Serial Designation A15-62T, Billet Steel Bars for Concrete Reinforcement, hard grade.

**13-01e Base Material:** The base material used under the curb, gutter and/or sidewalk shall be compacted to a minimum relative compaction of 95%. Native material may be used for a cushion if it meets the following requirements:

The material shall be a granular, sandy nature, free of vegetation and silt or clay, and shall have a minimum R-Value of 50, as determined by the Resistance Value Test in current use by the State of California, Department of Transportation.

**13-01f Lamp Black:** Lamp black shall conform in all respects to the latest revision of ASTM Serial Designation D209-47.

**13-01g Dowel Wrapping Paper:** Wrapping paper shall be basic 25 pound waxed clear paper equal in quality to "Kleerwrap" as manufactured by the Zellerbach Paper Company.

**13-01h Dowel Grease:** Grease for wrapping dowel bars shall be a 2A chassis lubricant as used in the automotive industry.

## 13-02 **OBSTACLES**

**Removal of Obstacles:** Existing curbs, sidewalks, culverts, trees, and other obstacles within one (1) foot of the back of the proposed sidewalk shall be removed and disposed of by the Contractor.

## 13-03 **GRADING**

The native earth under the curb, gutter and sidewalk section shall be rough graded and then carefully finish graded after full compaction to the neat section and grade as shown on the Plans.

## 13-04 **SETTING FORMS**

The forms shall be set true to line and grade and shall be held rigidly and securely in place by means of stakes set on the outside of the forms. The forms shall be kept in true alignment and to proper grade during all concrete placing operations.

## 13-05 **CONCRETE**

**13-05a Placing Expansion Joint Material:** The expansion joint material shall be placed at intervals as shown in the Standard Details so as to extend entirely through the concrete and shall be shaped to the cross-section of the curb, gutter and sidewalk. The joint material shall be held in a rigid position perpendicular to the plane of the curb, gutter and sidewalk by stakes or other adequate fastenings.

**13-05b Placing Dowels:** The dowels, if required, shall be placed as shown in the Standard Details. The bars shall be heavily greased and wrapped with paper to prevent adhering to the concrete. The bars shall be held in a **parallel** position with each other and **parallel** with the longitudinal axis of the curb, gutter or sidewalk by a suitable means as approved by the Engineer.

**13-05c Placing Concrete:** When the concrete has been placed between the side forms, a strike off guide shall be used to bring the surface to the proper section to be compacted. The concrete shall then be thoroughly tamped or vibrated to secure a dense mass.

**13-05d Finishing Concrete:** After full compaction, the concrete shall be floated with a float and troweled smooth. The sidewalk, curb and gutter shall then be broomed to give a light broom finish.

**13-05e Scoring:** The sidewalk shall be scored transversely every five (5) feet. Longitudinal scores shall be as shown in the Standard Details.

**13-06 TESTING FLOW LINES**

Immediately after the concrete has taken its initial set, the flow lines of the gutter shall be tested for irregularities by running water in the gutter. Should water form a puddle over 1/8 of an inch deep after the flow has ceased, the condition shall be remedied by adding or removing mortar, as the case may require. The flow line of the gutter shall be kept to a uniform grade. A straight edge of at least ten (10) feet in length shall be used for checking the flow line.

**13-07 CURING**

Immediately after the placing of the concrete has been completed it shall be treated with a liquid curing agent as approved by the Engineer.

**13-08 TOLERANCE**

The flow line of the gutter after all finishing has been completed shall not deviate more than one-eighth (1/8) inch from the established grade at any point.

**13-09 BACKFILL**

The space back of the curb or the sidewalk shall be backfilled and thoroughly tamped as near as practicable to the existing natural ground immediately after forms have been removed.

**13-10 CUTTING EXISTING PAVEMENT SURFACE**

When curbs, gutters and sidewalks are to be placed along an existing paved street, a straight line saw cut in the existing paving shall be made two (2) feet from and parallel with the proposed edge of the gutter. This two (2) foot area shall then be paved with identical materials to those which were removed, or a minimum of six (6) inches of asphaltic concrete surfacing.

## **14-00 STREET CONSTRUCTION**

### **14-01 MATERIAL**

**14-01a Aggregate Base:** The mineral aggregate for base course shall conform to Section 26-1.02B, California Standard Specifications, graded for 3/4 inch maximum Class 2 aggregate base.

**14-01b Aggregate Subbase:** In accordance with the requirements of the California Standard Specifications, the subbase material shall be compacted to a minimum relative compaction of ninety-five percent (95%).

The material shall be of a granular, sandy nature free of vegetation and silt and clay, and shall have a minimum R-Value of 50, as determined by the Resistance Value Test in current use by the State of California, Department of Transportation.

**14-01c Paint Binder:** The paint binder shall consist of an asphaltic type emulsion as specified in Section 94, California Standard Specifications.

**14-01d Prime Coat:** The liquid asphalt for prime coat shall be CS250, except that if weather conditions are unusual, modifications may be made.

**14-01e Surfacing:** The surfacing shall consist of Type B asphalt concrete with one-half ( $\frac{1}{2}$ ) inch maximum aggregate to conform to Section 39, California Standard Specifications. The bituminous binder shall be a steam-refined asphalt having a penetration range of 85-100.

### **14-02 SUBGRADE**

**Preparation:** The subgrade shall be prepared on the existing soil after all existing pavement, pavement base, debris and other objectionable materials and rubbish have been removed. It shall be compacted to a relative compaction of 95%. Subgrade preparation will include the removal of or furnishing of the necessary material to bring the subgrade to the required grade line. Excess material will be disposed of by the Contractor.

### **14-03 PLACING OF SUBBASE AND BASE COURSE**

The subbase and base course shall have a compacted thickness as shown on the Plans and shall be placed, shaped and compacted in accordance with Section 26 of California Standard Specifications. No base course shall be placed on any area where sewer pipes, water lines, electrical conduit or other conveyance conduit are to be construed until all such conduits have been fully completed and all backfilling fully compacted.

### **14-04 PLACING PRIME COAT OR PAINT BINDER**

**14-04a** Prime coat shall be applied in accordance with Sections 93-1.03 and 39-4.02, California Standard Specifications.

**14-04b** Prime coat shall be applied at a rate of 1/4 gallon per square yard or as directed by the Engineer.

**14-04c** Paint binder shall be applied in accordance with Sections 94-1.03 and 39-4.02, California Standard Specifications.

**14-05 PLACING OF PAVEMENT**

The compacted thickness of pavement shall be as shown on the Plans. The pavement materials shall be dried, proportioned and mixed, spread and compacted in accordance with Sections 39-1 through 39-7, California Standard Specifications.

**14-06 WATER FOR USE ON THE JOB**

The Contractor may obtain whatever water he needs for the prosecution of the job from the nearest fire hydrant available to the particular portion of the job affected. There will be no charge to the Contractor for the water utilized when on City owned projects.

**14-07 DUST CONTROL**

The Contractor / Developer shall take necessary measures to prevent the agitation of dust within the areas of the work. Regular monitoring shall be required. Upon notification of excess dust the Contractor / Developer shall respond immediately. If Contractor / Developer does not respond within a one hour time period, the City at its option may provide dust control at the Contractor / Developer's expense.

**14-08 SEAL COAT (RUBBER LATEX)**

Seal coat shall be fog, fine, medium fine, medium, coarse, or double as specified on the plans and in the specifications. All seal coats shall conform to the provisions in Section 37-1, "Seal Coats", of the CALTRANS Standard Specifications and these Special Provisions.

**14-09 DESIGN PARAMETERS FOR ALL NEW STREETS**

All new streets, whether in a new subdivision or in any other location within the City of Ripon, shall be designed by a consulting civil engineer or by the City Engineer after soil tests and traffic surveys have been conducted.

## 15-00 WATER DISTRIBUTION SYSTEM

### 15-01 MATERIAL

**15-01a.1 Pipe, (Ductile Iron Pipe):** Ductile iron pipe for water and other liquids shall be furnished in the sizes, classes, grades or nominal thicknesses, and joint types designated on the Plans or in the Special Provisions.

Ductile iron pipe shall comply with ANSI A21.51 (AWWA C151) and shall be used on all water crossings or where required by State Health Code sanitary sewer water line clearance regulations. Pipe shall utilize either flange, mechanical or push on rubber gasketed joints.

Pipe shall be minimum standard thickness Class 50 with standard cement lining (USA Std. A21.4).

Ductile iron pipe joints shall comply with the following requirements for the types specified on the Plans or in the Special Provisions:

<u>Type of Joint</u>	<u>Specifications</u>
Rubber Gasket Push-on Joint	ANSI A21.11 (AWWA C111)
Mechanical Joint	ANSI A21.11 (AWWA C111)
Flanged Joint	ANSI B16.1, B.16.2 and A21.10 (AWWA C110)
<u>Flanged Joint (Threaded Flanges)</u>	<u>ANSI B2.1.</u>

All rubber gasket, push-on, mechanical and flanged joint fittings for cast iron or ductile iron water pipe shall be manufactured in accordance with ANSI A21.53 (AWWA C110) Class 350.

Unless otherwise specified, the internal surfaces of ductile iron water pipe and fittings shall be lined with a uniform thickness of cement mortar then sealed with a bituminous coating in accordance with ANSI A21.4 (AWWA C104). The outside surfaces of cast iron and ductile iron pipe and fittings for general use shall be coated with a bituminous coating 1 mil (0.0254 mm) thick in accordance with ANSI A21.6 or ANSI A21.51.

**15-01a.2 Pipe, (Polyvinyl Chloride (PVC) Pipe):** Polyvinyl Chloride pipe shall be furnished in the classes, sizes, and grades designated on the Plans and Special Provisions.

Polyvinyl Chloride pipe shall meet the requirements of AWWA C-900 "Polyvinyl Chloride (PVC) Pressure Pipe" for pipe sizes 4" through 12", AWWA Class 150 minimum. All Class 150 pipe shall meet the requirements of DR 18 and Class 200 pipe shall meet the requirements of DR 14 with cast iron O.D.

For pipe sizes 14" and above, the Polyvinyl Chloride (PVC) pipe shall meet the requirements of AWWA C-905, Polyvinyl Chloride (PVC) Water Transmission Pipe, minimum class 165, DR 25. All class 235 pipe shall

meet the requirements of DR 18.

All pipe shall be suitable for use as a pressure conduit. Provisions shall be made for expansion and contraction at each joint with an "O" ring elastomeric gasket seal meeting the requirements of ASTM D-3139 and F-477. Solvent welded joints will not be permitted. The bell section shall be designed to be at least as strong as the pipe wall.

Fittings for PVC pipe shall be cast iron only.

The cast iron flanged fitting shall be American Standard Cast Iron Flanged Fitting, Class 350. All flanged joints shall be fabricated with the use of mild steel square head and square nut American Standard Regular Machine Bolts.

**15-01b Gate Valves:** All Gate Valves shall be in accordance with the following specifications:

1. Valve shall conform to AWWA C509, latest revision, Standard for Resilient Seated Gate Valves.
2. Wedge shall be constructed of ductile iron, encapsulated in synthetic rubber.
3. Wedge rubber shall be molded in place and bonded to the ductile iron wedge, and shall not be mechanically attached with screws, rivets or similar fasteners.
4. Wedge shall seat against seating surfaces arranged symmetrically about the centerline of the operating stem, so that seating is equally effective regardless of direction of pressure unbalance across the wedge.
5. Stem shall be sealed by three O-rings; (2) above the stem collar (1) below the stem collar. Upper stem seals shall be replaceable with valve fully open and while being subjected to full rated pressure.
6. Waterway shall be smooth and shall have no depressions or cavities in seat area where foreign material can lodge and prevent closure or sealing.
7. Valve body and bonnet shall be epoxy coated, inside and out, with fusion-bonded epoxy. Coatings shall conform to AWWA C550, latest revision, Standard for Protective Interior Coatings for Valves and Hydrants.

**15-01c Valve Boxes and Covers:** See Standard Details for valve boxes and covers.

**15-01d Mechanical Joint Restraint:** The following specifications shall be followed all mechanical joint connections (all mechanical joints shall be restrained joints):

1. Grip Ring and Gland: Ductile Iron, meet ASTM A 536-80, Grade 65-45-12. Grip ring is to be painted red for IPS, black for D.I.

and yellow for C-900 pipe.

2. Gasket: Virgin SBR compounded for service. Meets ASTM D 2000 MBA 710-90.
3. T-Bolts & Nuts: 3/4" national coarse high strength low alloy steel T-bolts and heavy hex nuts. Steel meets AWWA C-111-90 composition specification.

**15-01e Concrete for Thrust Block and Casements:** The Portland Cement concrete shall be Class B with one and one-half (1 ½) inch maximum aggregate size and shall be proportioned, mixed, placed and protected in accordance with Section 90, California Standard Specifications.

**15-01f Disinfection Agent:** Disinfection agent shall be in accordance with AWWA C651-92 "AWWA Standard for Disinfecting Water Mains".

**15-01g Pipe and Fittings for Water Services:** The pipe, tubing, fittings, stops and accessories shall be as follows:

**1. Water Pipe and Tubing**

- a. For 1" water services, use ultra high molecular weight (UHMW), high density polyethylene (HDPE) pipe, ASTM 2239/PE3408, as manufactured by Driscopipe, WESFLEX, or approved equal, rated at 160 psi, SDR-7, in iron pipe size (IPS).
- b. For 1 ½" and 2" water services, use ultrahigh molecular weight (UHMW), high density polyethylene (HDPE) tube, ASTM D-2737/PE3408, as manufactured by Driscopipe, WESFLEX, or approved equal, rated at 200 psi, SDR-9, in copper tube size (CTS).

**2. Corporation Stops**

- a. 1" HDPE pipe: use James Jones J-3404, Ford F1101, or approved equal.
- b. 1 ½" or 2" HDPE tube: use James Jones J-1937, Ford FB1100 or approved equal.
- c. All fittings shall have AWWA-CC threaded inlets.
- d. All HDPE pipe and tube compression connections shall use manufacturer's recommended stainless steel insert.



### **3. Ells**

- a. For 1" HDPE pipes, use James Jones J-2611, Ford L66-44, or approved equal.
- b. For 1 ½" or 2" HDPE tube, use James Jones J-2611, Ford L44-66 for 1 ½" tube, Ford L44-77 for 2" tube, or approved equal.
- c. All HDPE pipe and tube compression connections shall use manufacturer's recommended stainless steel inserts.

### **4. Meter Setter**

- a. For 1" HDPE pipe, use FORD 70-80 Series Coppersetter, VH74-84W-11-44 with C86-44 adapter.
- b. For 1 ½" and 2" HDPE tube, 1 ½" - use FORD 70-80 Series Coppersetter, VBH76-86-15-11-66 with C84-66 adapter, 2" - use FORD 70-80 Series Coppersetter, VH74-84 W-11-44 with C84-77 adapter.
- c. All meter setter valves shall include lock wings.
- d. All HDPE pipe and tube compression connections shall use manufacturer's recommended stainless steel inserts.

### **5. Service Clamp:**

- a. The service saddle for all sizes of water service lines shall be a James Jones J996, Ford S91 or approved equal, AWWA-CC threaded outlet and a BONA-N rutter seat gasket.

### **6. Meter Boxes:**

- a. For 1" water services, use a Christy No. B-16 body or approved equal. Lids shall be concrete with reading lid feature or cast iron for traffic exposure such as a Christy B16g or Christy B16-61g respectively or approved equal.
- b. For 1 ½" and 2" water services, use a Christy No. B-36 body or approved equal. Lids shall be concrete with a reading lid feature or for traffic exposure a steel cover such as a Christy B36g or Christy B36-61g respectively or approved equal.
- c. Where H-20 traffic loading is expected, a special box and lid such as a Christy B-1720 with ½" steel lid as approved by the engineer shall be used.

## **7. Meter Idler Pipe**

- a. For 1" water service use a 10 3/4" long idler pipe, Ford #4 Idler, or approved equal.
- b. For 1 1/2" water service, use a 13" long idler pipe, Ford #6 Idler, or approved equal.
- c. For 2" water service, use a 17" long idler pipe, Ford #7 Idler, or approved equal.

## **8. Trace Wires**

- a. A trace wire running from the angle curb stop back to the corporation stop shall be installed. The tracer wire shall be a minimum #12AWG copper wire, type XHHW.

## **15-02 PIPE INSTALLATION**

**15-02a Pipe Handling:** The pipe shall at all times during loading, unloading, moving and laying operation, be handled with care. Only methods of handling as approved by the Engineer shall be used in these operations. When using mechanical equipment, extreme care shall be used to avoid damage or scarring by placing of hooks, chains or other devices on the end of the pipe. The Engineer shall be the judge of whether a pipe is seriously damaged and any pipe so classified shall be permanently removed from the site of the work.

**15-02b Pipe Cleaning:** The inside of all couplings and the matched ends of all pipe to be coupled, and the inside of all pipe, shall be free from dirt, grease or other deleterious material. The open ends of all pipe previously laid shall be adequately plugged whenever pipe laying operations are completed at the end of each work day or suspended for any reason.

**15-02c Pipe Laying:** The bottom of the trench shall be carefully graded to the established line and grade. Where unstable or unsuitable material is encountered in the bottom of the trench, the trench shall be excavated at least three (3) inches below the established grade and the trench refilled with suitable material properly compacted. Select fine damp earth shall then be placed and thoroughly compacted in the bottom of the trench to form earth mounds under the "supporting points" of the pipe. The mounds shall run at right angles across the trench and be at least six (6) inches under the coupling. The pipe shall be laid in the trench supported by the earth mounds. A thin thickness of a nontoxic and water soluble lubricant shall be applied to the entering level and back of the first machined shoulder of the pipe to be coupled. The rubber rings shall be set in the coupling grooves, and the coupling shall be placed between the pipe ends. The pipe shall be moved so that the ends butt against the rubber rings. A jacking or pulling device approved by the Engineer shall be used to pull the pipe and coupling into proper position. An expansion space of not less

than 1/8 inch and not more than 1/4 inch shall be left between the ends of all pipes joined. A representative of the pipe manufacturer shall be present when the pipe laying commences in order to ensure the proper installation of the pipe. All pipe damaged during construction operations shall be replaced by the Contractor at his expense to the satisfaction of the Engineer.

### **15-03 TESTS AND TOLERANCES**

**15-03a Testing:** The test for hydrostatic pressure shall commence no sooner than seven (7) days after the last concrete thrust block has been cast with standard cement or at least after thirty-six (36) hours with high early strength cement, after backfilling and compacting trench to the plane upon which the asphalt concrete surfacing is to be placed. These tests may be made whenever a section of pipe between two valves has been completed. All equipment, material, devices and supplies for the test shall be furnished by the Contractor. The Contractor shall take the necessary steps to ensure that the pipe, fittings, couplings, valves and other appurtenances are not displaced during the test. The pipe shall be filled with water at least 24 hours prior to the time of the test. Each section shall be subjected to a hydrostatic test pressure of 150 pounds to a square inch for two hours. During this period of test, all pipes and joints shall be inspected for leaks and any leaks, failures or imperfect construction developed during the period of test shall be corrected by the Contractor at his own cost and expense.

**15-03b Tolerances:** After the pressure test has been completed, the line shall be maintained at a sixty (60) pound per square inch operating pressure for a period of one week and the rate of leakage shall not exceed fifty (50) gallons per each inch of diameter per mile in a 24 hour period. It shall be the Contractor's responsibility to locate and repair the points of line failure; fill, recompact the trench and retest the section of line in the event the line fails the leakage test.

### **15-04 THRUST BLOCKS**

Thrust blocks shall be located at the ends of mains, where bends occur, at tees in pipe, and at other locations where a thrust occurs. The thrust blocks shall bear against unexcavated material adjacent to the trench. The concrete block shall be wedge shaped and the concrete shall be kept behind the hub or flange of all fittings. All fittings shall be wrapped in at least 3 mil plastic prior to placing thrust block. See the Standard Details for thrust block sizes.

### **15-05 DISINFECTION OF SYSTEM**

All new water lines shall be completely isolated from any existing main until they have been tested and disinfected, as described below, to the satisfaction of the Engineer. New mains may be filled from existing mains only by temporary tap thereto and through a system on one (1) shut-off

valve and two (2) check valves so arranged as to provide positive backflow prevention. When the new main is properly disinfected and the isolation dam is removed from connection flange or other type connection is made, extreme care shall be exercised to prevent the entry of contamination. Connection fittings shall be thoroughly swabbed with an approved bactericide immediately prior to their installation.

All disinfection of water lines shall be in accordance with AWWA C651-92 "AWWA Standard for Disinfecting Water Mains". The following section titles are included in this AWWA standard.

- Section 1: General
- Section 2: Forms of Chlorine for Disinfection
- Section 3: Basic Disinfection Procedure
- Section 4: Preventive and Corrective Measures During Construction
- Section 5: Methods of Chlorination
- Section 6: Final Flushing
- Section 7: Bacteriological Tests
- Section 8: Redisinfection
- Section 9: Final Connections to Existing Mains
- Section 10: Disinfection Procedures When Cutting Into or Repairing Existing Mains
- Section 11: Special Procedure for Caulked Tapping Sleeves

All bacteriological sampling will be taken and processed by a certified laboratory.

## **15-06 FIRE HYDRANTS**

Fire hydrants shall be:

1. Equipped with two (2) - 2 ½" (two and one-half inch) outlets, one (1) - 4 ½" (four and one-half inch) outlet and a 6" (six inch) mounting flange.
  - a. Each outlet will be controlled by a separate valve
  - b. All outlets will be equipped with right hand National Standard threads.
2. Placed with the 4 ½" (four and one-half inch) outlet facing the street.
3. Placed with the center of the 4 ½" (four and one-half inch) outlet 18"-24" (eighteen to twenty four inches) above the surface of the sidewalk or adjoining pavement.
4. Painted with two (2) finish coats of Long Beach Iron Works yellow or light (safety) yellow (Ellis-Hilux 1145-245 or equivalent), any other paint shades shall be approved by the fire chief.
5. Fusion bonded epoxy lined (interior of hydrant) with 3M Scotch-Kote 302 or equivalent (minimum of 8 mils thickness).
6. Installed with tracer wire. Tracer wire is to be wrapped around

the base of the fire hydrant spool and connected to the main line tracer wire via the fire hydrant lateral.

Any/all exceptions to these specifications and all fire hydrant locations shall be approved, in writing, by the Fire Chief of the Ripon Consolidated Fire District prior to the installation of said fire hydrant.

The following are "approved" fire hydrants:

1. Clow Manufacturing, Model #960
2. All others to be approved by the Ripon Fire Chief.

The following are "approved" break-off check valves:

1. Long Beach Iron Works, Model #LB400
2. All others to be approved by the Ripon Fire Chief.

#### **15-07 BACKFILLING**

Backfilling shall be done as specified in Sections 10-03 and 10-04 as applicable.

#### **15-08 TRACER WIRE**

A "tracer wire" shall be attached to all non-metallic water lines as follows:

This "tracer wire" shall be firmly attached to the **top** of all lines in the streets, as well as on the service lines to each lot. The wire shall be continuous through all valves and fittings and, in the case of lot services, shall terminate at the curb valve box. The wire shall be a minimum of 12-gauge, coated copper.

## **16-00 NONPOTABLE WATER SYSTEM**

### **16-01 INTRODUCTION**

**16-01a Purpose of Guidelines:** The purpose of these guidelines is to provide guidance for planning, designing, constructing, and operating nonpotable water systems. The guidelines do not address the use of "Gray Water" or on-site treatment systems, due to the lack of quality control of these on-site supplies.

These guidelines are organized into six sections and are followed by appendices. The first section provides a brief introduction to the non-potable water system. The second, third, and fourth sections provide essential design criteria and specifications for the construction of the offsite transmission, storage, pumping, and other facilities. The fifth section provides essential design and operating requirements for the water user's on-site facilities. The sixth section provides a description of the system management required to assure continued compliance with applicable State and local laws.

**16-01b Introduction to the Non-potable Water System:** The non-potable water systems referred to in these guidelines consist of the pumping, distribution, and other facilities necessary to supply non-potable water from its source to its point of use on the customer's property. Non-potable water can only be used for irrigation and industrial purposes.

### **16-02 TRANSMISSION / DISTRIBUTION LINES**

This section provides criteria for protection against the misuse of transmission/distribution facilities. Cross-connection control is needed to prevent a non-potable main from mistakenly being connected to a potable system. Therefore, the location, depth, mode of identification, and types of above-ground appurtenances such as air/vac assemblies, blow-offs, etc., should be clearly identified in order to avoid cross-connections or inappropriate uses with potable water use.

**16-02a Pressure:** Minimum pressure at the user's meter at the peak demand hour is set at 10 psi less than that for the potable water supply.

**16-02b Minimum Depth:** The non-potable line should be a minimum of 12-inches below that for potable water.

**16-02c Minimum Separation:** Non-potable water lines parallel to potable water lines should be installed at least ten feet horizontally from and one foot lower than the potable water lines. Non-potable water lines should cross a minimum of one foot below potable water lines. Where separations cannot be maintained, consult with the City Engineer for construction requirements.

#### **16-02d Pipe Identification:**

- (1) General** - All new buried transmission/distribution piping in the non-potable water system, including service lines, valves, and other appurtenances should be colored purple (Panatone 522C) and integrally stamped/marked **CAUTION: NONPOTABLE WATER - DO NOT DRINK.**

Existing potable water lines that are being converted to non-potable use should first be accurately located and tested in coordination with the City Engineer's requirements. If the existing lines meet approval of the City, the lines should be approved for non-potable distribution. If verification of the existing lines is not possible, the lines should be uncovered, inspected, and identified prior to use.

#### **16-02e Valve Box and Other Surface Identification:**

- (1) General** - Valve boxes should be the standard concrete or fiberglass box with a special triangular, heavy-duty cover (G4 valve box with "NPW" embossed on lid. All valve covers on offsite non-potable transmission water lines should be of non-interchangeable shape with potable water covers and with a recognizable inscription cast on the top surface.
- (2) Identification** - All above ground facilities should be consistently color-coded (purple, Panatone 512C) and marked to differentiate non-potable water facilities from potable water or wastewater facilities.

**16-02f Blow-off Assemblies:** Either an in-line type or end-of-line type blow-off or drain assembly should be installed for removing water or sediment from the pipe. The line tap for the assembly should be no closer than 18-inches to a valve, coupling, joint, or fitting unless it is at the end of the line.

#### **16-03 CANAL WATER**

**16-03a** If canal water is used, it will be treated to remove and prevent algae growth and remove suspended and settleable solids. Chlorination may be required as part of the treatment system.

#### **16-04 PUMPING**

The pumping facilities to distribute non-potable water will identify the type of water being handled, and will provide acceptable backflow protection.

**16-04a Marking:** All exposed and above ground piping, fittings, pumps, and valves are painted purple. In addition, all piping is identified by labels reading "CAUTION" NONPOTABLE WATER - DO NOT DRINK". In a

fenced pump station area, at least one sign should be posted on the fence which can be readily seen by all operations personnel using the facility.

**16-04b Surge Protection:** All systems should have proper surge protection facilities to prevent the loss of non-potable water through broken piping resulting from water hammer and pressure surges.

**16-04c Sealing Water:** Any potable water used as seal water for non-potable water pump seals should be adequately protected.

## **16-05 ON-SITE APPLICATIONS**

### **16-05a Strainers at Meter/Point of Connection:**

- (1) **General** - Strainers may be required at the consumer's meter.
- (2) **Type** - Strainers of the following types are generally satisfactory.
  - (A) Wye strainers: Not recommended for below-ground (in vaults) installations.
  - (B) Basket strainers: Suitable for above or below-ground (in vaults) installations.
  - (C) Filter strainers: Normally used above ground on drip irrigation systems.
- (3) **Placement:** Strainers are normally the same size as the line and can be installed either before or after the meter.
  - (A) Before meter: Installation before the meter will protect the meter as well as the on-site system. Maintenance in this case is the responsibility of the City.
  - (B) After Meter: Installation after the meter will not provide meter protection, and maintenance is the responsibility of the user. Strainers can range in mesh size from 20 to 325. A mesh of 20 to 80 is normally adequate.

**16-05b Controllers:** Controllers are used to automatically open and close on-site distribution valves.

- (1) They should be fully automatic.
- (2) They should have multiple starting times that can be selected for any time of day, seven (7) days a week, and should be equipped with moisture sensors to avoid activation during rainy periods.



- (3) Station durations should be capable of delivering water from one minute to 60 minutes per each start time.
- (4) An appropriate sized drawing of the area served by the controller should be sealed in a plastic cover and placed in the controller and updated if the system is changed.
- (5) Controllers of non-potable water should be color-coded to differentiate the non-potable water from the potable water in accordance with Section 16-02a(1) and Section 16-02a(2).
- (6) Controllers should be labeled inside and outside, warning that the system is utilizing non-potable water. The labels should also alert the system's owner/maintenance personnel of any important constraints on the operation of the system in accordance with Sections 16-02a(1) and Section 16-02a(2).

**16-05c Backflow Protection:** Backflow protection with an approved air gap (AG) must be provided at the potable water service connection. A reduced pressure principle device (RPPD) backflow prevention device may be provided only when approved by the health department and the City.

If temporary potable water connections to the non-potable water system are required, the connections should be protected in the same manner as a permanent connection. Exceptions may be necessary under special circumstances, but are not allowed unless approved by the City.

**16-05d Pipe Identification:** New on-site pipelines should be identified as non-potable water pipes by using a purple color code, Panatone 522C for pipe and other appurtenances, Panatone 512C for marking tapes, labels, signs, etc., and markings, differentiating them from potable water piping.

All piping and valves must also be appropriately labeled or continuously taped with appropriate identification.

When an existing potable water line is converted to non-potable usage, the water line should be accurately located and tested in accordance with City requirements. If required, necessary actions shall be taken to bring the water line and appurtenances into compliance with City standards. If verification of the existing line is not possible, the line should be uncovered, inspected, and identified prior to use.

- (1) **Warning Tape** - A warning tape should be installed on pressure and/or non-pressure laterals. A purple tape, Panatone 512C, with black or white lettering stating "CAUTION: NONPOTABLE WATER LINE BELOW - DO NOT DRINK" should be fastened directly to the top of the pipe. The tape should run continuously the entire length of the pipe and should be at least 3-inches in width.

- (2) **Colored Pipe** - The use of purple colored pipe, color Panatone 522C, or purple polyethylene vinyl wrap, Panatone 512C, with the words "CAUTION: NONPOTABLE WATER - DO NOT DRINK", printed on the pipe, or tape, is an acceptable alternative. The warning should be stamped on opposite sides of the pipe, repeated every three feet.

**16-05e System Identification:** The non-potable water system should be identified in such a manner as to differentiate it from a potable water system.

- (1) **Hose Bibs** - Hose bibs are not allowed on non-potable irrigation systems.
- (2) **Lines** - When potable water is being supplied to an area also being supplied with non-potable water, the potable water main should also be identified. A purple color coded tape, Panatone 512C, with the words "CAUTION--DRINKING WATER LINE" should be fastened directly to the top of the potable water pipe and run continuously the entire length of the pipe. This tape should be at least 3-inches in width. The color code should differentiate potable water from non-potable water.

**16-05f Proximity of Utilities:**

- (1) **Horizontal Separation** - A 10-foot separation of the non-potable water pipe should be maintained at all times between a potable water pipe and/or a parallel sanitary sewer system. If a 10-foot separation is not possible, the approval for special construction requirements should be obtained from the City Engineer. Common trench construction is not permitted. A minimum of a 4 foot horizontal separation should be maintained.
- (2) **Vertical Separation** - The potable water pipe should be installed a minimum of one foot above the non-potable water pipe, and sanitary sewer system. If a one foot separation is not possible, the approval for special construction requirements should be obtained from the City Engineer.

**16-05g Drinking Fountains/Public Facilities:** Potable water drinking fountains and other public facilities should be placed so as to avoid contamination from non-potable water use, or otherwise protected.

Exterior drinking fountains and other public facilities should be shown and called out on the construction plans. If no exterior drinking fountains, picnic tables, food establishments, or other public facilities are present in the design area, then it should be specifically stated on the plans that none are to exist.

**16-05h Construction Water:** Water trucks, hoses, drop tanks, etc. should be identified as containing non-potable water and not suitable for drinking.

- (1) **Permits** - The use of non-potable water for construction purposes requires approval of the City Engineer.
- (2) **Uses** - Non-potable water used for construction purposes may only be used for soil compaction during grading operations, dust control and consolidation and compaction of backfill in non-potable water, sanitary sewer, storm drain, gas and electric pipeline trenches. Reclaimed water may not be used for water jetting and consolidation or compaction of backfill in potable water pipeline trenches.
- (3) **Equipment** - Equipment operators should be instructed about the requirements contained herein and the potential health hazards involved with the use of non-potable water.

Non-potable water should not be introduced into any domestic water piping system. No unprotected connection should be made between equipment containing non-potable water and any part of a domestic water system.

**16-05i Specific Provisions:** Some restrictions are placed on the operation of non-potable water systems as a matter of good practice and to protect public health. The following restrictions applied by the City should be included in the detailed design:

- (1) **Runoff Conditions** - Conditions which directly or indirectly cause a runoff outside of the approved use area are prohibited.
- (2) **Ponding Conditions** - Conditions which directly or indirectly cause ponding (puddles of standing water) outside of or within the approved use area are prohibited.
- (3) **Overspread Conditions** - Conditions which directly or indirectly permit windblown spray or overspread to pass outside of the approved use area are prohibited.
- (4) **Unapproved Uses** - Use of non-potable water for any purpose other than those explicitly approved in the currently effective user permit issued by the City and without the prior knowledge and approval of the appropriate regulatory agencies, shall be prohibited.
- (5) **Reuse/Disposal in Unapproved Areas** - Reuse/disposal of non-potable water for any purpose, including approved uses, in areas other than those explicitly approved in the currently

effective user permit issued by the City, and without the prior knowledge and approval of the appropriate regulatory agencies, shall be prohibited.

- (6) **Cross-Connection** - Cross-connections resulting from the use of a non-potable water service, whether by design, construction practice, or system operations, shall be prohibited.
- (7) **Hose Bibs** - Hose bibs on non-potable water systems are prohibited. (See 16-05e(1))
- (8) **Food Establishments/Public Facilities** - In order to prevent food from being exposed to spray from the irrigation system, non-potable water irrigation systems should be designed to avoid potential contamination of hazardous water to picnic tables and drinking fountains see 16-05g.)

**16-05j Irrigation Application Rate and Practice:** An irrigation system designed for non-potable water should specify type of sprinkler, placement of sprinkler, type of plants, etc., to be used so as to prevent runoff, ponding and overspread.

- (1) **Runoff** - Non-potable water should be applied at a rate that does not exceed the infiltration rate of the soil. The irrigation system should not be allowed to operate for a time longer than the landscape's water requirement. If runoff or ponding occurs before the landscape's water reprogrammed with additional watering cycles to meet the requirements and prevent runoff.
- (2) **Irrigation Period** - To the extent possible, the operation of the irrigation system should be during periods of minimal public use of the approved area. Such periods of operation should remain within any general period of non-potable water irrigation operation specified by the City.

**16-05k Equipment and Facilities:** Any equipment or facilities such as tanks, temporary piping or valves, and portable pumps which have been used with non-potable water should be cleaned and disinfected before removal from the approved use area for use at another job site. This disinfection and cleaning should ensure the protection of the public health in the event of any subsequent use as approved by the agency supervisor and the disinfection process should be performed in his or her presence.

**16-05l Warning Signs and Labels:** Warning labels should be installed on designated facilities such as, but not limited to, controller panels and wash down or blow-off hydrants on water trucks temporary construction services. The labels should indicate that the system contains non-potable water that is unsafe to drink.

Where non-potable water is used for recreational impoundments, warning signs should be installed to notify that the water in the impoundment is unsafe to drink. A detailed plan should be prepared showing placement and spacing of the proposed signs. Where non-potable water is used for irrigation, warning signs should be installed, and contain as a minimum, ½" black or white letters on a purple background notifying the public that the water is unsafe to drink.

Warning signs and labels should read "DO NOT DRINK--NONPOTABLE WATER", and should be in both English and other language(s) common to the particular area. The signs should include the international system for do not drink.

## **16-06 SYSTEM MANAGEMENT**

Quality control, use control, operation and maintenance control, cross-connection prevention and assurance against violation of the City's requirements are some of the management considerations.

**16-06a Quality Control:** All non-potable water delivered to users from the City's facilities conform to requirements established by the appropriate regulatory agencies.

### **16-06b Control of On-site Use:**

- (1) On-site Use Requirements** - Only after the appropriate applications have been filed and authorization has been granted by the City shall non-potable water be furnished for the intended uses.
- (2) User Supervisor** - The user should include in the application for non-potable water service the following information regarding the individual designated as user supervisor: name, address, and telephone number at which this individual or designated representative can receive messages during "off hours." The agency should approve the designated person, or reject the designation for just cause. It should be the responsibility of the user to notify the City of a change in designation of the user supervisor. Following such notification, the agency should again perform its evaluation.

The user supervisor should be aware of the entire system within his or her responsibility and of all applicable conditions of non-potable water use. The user supervisor should be responsible for the installation, operation and maintenance of pipelines and cross-connection equipment.

- (4) Authorized Uses for Non-potable Water** - The uses of non-potable water may include landscape irrigation, agricultural irrigation, construction water, industrial process water, and recreational impoundment. Each such use should be considered for approval by the City on a case-by-case basis.

The allowed uses are in accordance with the standards of treatment and water quality regulations of the State. The City may set forth specific requirements as conditions prior to approving any such uses and/or require specific prior approval from the appropriate regulatory agencies.

- (4) Emergency Connections to Potable Water Systems** - Permanent emergency connections to the potable water system are prohibited. A temporary connection to the potable water system under special emergency conditions may be made only after the City has given specific approval in writing. (See 16-05c).
- (5) Responsibility for Maintenance** - Unless otherwise specified, the user is responsible for maintaining all on-site facilities (downstream of the user's service meter). Unless otherwise specified, all on-site facilities are under the ownership of parties other than the City.

**16-06c Facilities Operation (Also see Appendix B):**

- (1) On-site Facilities--General** - The operation and surveillance of on-site domestic water distribution and non-potable water distribution facilities to avoid cross-connections shall be the responsibility of the user.
- (2) City Supervisor** - The City has a designated supervisor to be responsible for the operation of the offsite distribution system, for the surveillance of all users and for the determination of water quality as it relates to compliance with requirements of the City. The name and designated function of this individual is listed by the City on the service application form and is kept updated at the City office.

The City supervisor is knowledgeable of the entire system and applicable conditions of non-potable water use. The City supervisor should be the contract person for the City in all matters between the user and the City concerning the operation of the non-potable water system.

- (3) On-site Non-potable Water Facilities** - The operation and surveillance of all on-site non-potable water systems facilities is under the management of the City supervisor. The City has the right to enter upon the user's premises during

reasonable hours for the purpose of inspecting the non-potable facilities and their operation. The user has the following responsibilities in relation to the operation of the on-site facilities:

- A.** Make sure that all operations personnel are trained in and familiarized with the use of non-potable water.
- B.** Furnish the operations personnel with maintenance instructions, controller charts, and record drawings to insure proper operation in accordance with the on-site facilities design.
- C.** Prepare and submit to the City required record drawings.
- D.** Notify the City of any and all updates or proposed changes, modifications or additions to the on-site facilities. Changes should be approved by the City and should be designed and constructed according to the requirements, conditions and standards set forth in the City's requirements.
- E.** Insure that the non-potable water facilities remain in accordance with the City's requirements. (See 16-05i).
- F.** Operate and control the system in order to prevent direct human consumption of non-potable water and to control and limit runoff. The user should demonstrate responsibility for any and all subsequent uses of the non-potable water.
- G.** Report to the City any and all failures in the non-potable water systems that cause an unauthorized discharge of non-potable water.
- H.** Comply with any and all applicable Federal, State and local statues, ordinances, regulations, contracts and requirements prescribed by the City. In the event of violation, any charges and penalties may be applied and collected by the appropriate regulatory agency.
- I.** Install and maintain signs at all facilities.

**16-06d Non-potable Water Systems:** The City will monitor and inspect the entire non-potable water system including both on-site and offsite facilities as deemed necessary. The City, for monitoring, record keeping, and providing reports, has the right to enter the user's premise during reasonable hours. The purpose of inspecting on-site non-potable water facilities and areas of non-potable water use is to assist the user in complying with requirements.

## 16-06e Violations:

- (1) **Determination** - The City reserves the right to determine whether a violation of the guidelines has resulted from any action or occurrence which is the responsibility of a user. If the violation constitutes a violation of any regulatory agency requirement, the City should make its determination on behalf of the concerned regulatory agency. If a violation is verified, the City should notify the user and confirm that it is corrected.
- (2) **Specific Violations** - Specific violations should include those which directly cause noncompliance with any one of the specific prohibitions as listed in the permit issued by the City. However, by definition, noncompliance with any condition or conditions of the guidelines of the regulatory agency, whether willingly or by accident, should constitute a violation.
- (3) **Notification** - It should be the responsibility of the user to notify the City of any and all failures in a non-potable water system whether or not in the user's opinion the failures resulted in violations. It should also be the responsibility of the user to notify the City of any and all violations which occur as a result of the user's action, the action of the operations personnel, or any use of the non-potable water service. If there are any doubts regarding whether a violation has occurred, the user should notify the City so that a determination can be made.

Notification of failures and violations should be made as soon as possible or, in any event, no later than noon on the next regular working day following the occurrence. Such notification should be made by telephone to the City's supervisor or designated representative.

- (4) **Corrective Action** - If the City supervisor's investigation results in the determination that a violation has occurred, then it is the responsibility of the user to initiate corrective action. A timetable for completing the corrections should be negotiated with the City supervisor by the user, with the final approval of the City. Such corrections may involve human factors, such as additional training or procedures modifications, as well as physical alterations to the system.

If the corrective actions are required, the user shall submit to the City, in writing, a statement describing the violation or violations, summarizing the corrective action to be taken and setting forth the negotiated timetable. This written submittal should be reviewed by the City supervisor. Until the corrections are completed and approved by the City, the use



of non-potable water should continue only to the extent permitted by the City and other regulatory agencies.

## **17-00 STORM WATER POLLUTION PREVENTION**

The purpose of these guidelines is to provide guidance for planning, designing, constructing, and maintaining Storm Water Pollution Prevention (SWPP) measures. All SWPP measures are based on the Best Management Practices (BMP) outlined and detailed in the California Stormwater BMP Handbooks, written and distributed by the California Stormwater Quality Association (CASQA). For a complete listing and explanation of all the possible BMPs to be used for storm water pollution prevention, refer to the BMP Handbook (January 2003).

### **17-01 NOTICE OF INTENT,WDID, AND SWPPP**

All developers/builders shall submit a Notice of Intent (NOI) to the State Water Resources Control Board for all projects greater than 1 acre in size. A copy of the NOI and the WDID number issued by the state shall be submitted to the City of Ripon prior to the commencement of any project. A storm Water Pollution Prevention Plan (SWPPP) shall be submitted to the State and City for review prior to beginning any project.

### **17-02 STORM DRAIN INLET PROTECTION**

**17-02a Gravel Bag Barriers:** The gravel bag barrier is located in the gutter pan as shown in the standard drawings section of this book. The gravel bag barrier at curb inlets shall be accompanied by sediment filter bag inserts. In areas of high clay and silts, use filter fabric and gravel as additional filter media. Gravel bags should be used due to their high permeability. The barriers should be constructed per the standard detail and as follows:

1. Use sand bag made of geotextile fabric (not burlap) and fill with  $\frac{3}{4}$ " rock or  $\frac{1}{4}$ " pea gravel.
2. Construct on gently sloping street.
3. Leave room upstream of barrier for water to pond and sediment to settle.
4. Place several layers of sand bags – overlapping the bags and packing them tightly together.
5. Leave gap of one bag on the top row to serve as a spillway. Flow from a severe storm (e.g. 10 year storm) should not overlap the curb.

#### **Materials:**

**Bag Material:** Bags should be woven polypropylene, polyethylene or polyamide fabric or burlap; minimum unit weight of 4 ounces/yd<sup>2</sup>, Mullen burst strength exceeding 300 lb/in<sup>2</sup> in conformance with the requirements in ASTM designation D3786, and ultraviolet stability exceeding 70% in conformance with the requirements in ASTM designation D4355.

**Bag Size:** Each gravel-filled bag should have a length of 18 inches, width of 12 inches, thickness of 3 inches, and mass of approximately 33 lbs. Bag dimensions are nominal, and may vary based on locally available material.

Fill Material: Fill material should be 0.5 to 1 inch Class 2 aggregate base, clean and free from clay, organic matter, and other deleterious material, or other suitable open graded, non-cohesive, porous gravel.

### **17-03 FIBER ROLLS**

A fiber roll consists of straw, flax, or other similar materials bound into a tight tubular roll. Fiber rolls shall be placed at the back of curbs/sidewalks in subdivisions, and at the toe and face of slopes to intercept runoff and reduce flow velocity. Fiber rolls shall also be used as check dams in unlined ditches to prevent sediment from entering the storm drain system.

**17-03a Fiber Roll Materials:** Fiber rolls should be either prefabricated rolls or rolled tubes of erosion control blanket.

**17-03b Assembly of Field Rolled Fiber Rolls:** Roll length of erosion control blanket into a tube of minimum 8 inches in diameter. Bind roll at each end and every 4 ft. along length of roll with jute-type twine.

**17-03c Installation:** Fiber rolls shall be staked into a 2" to 4" deep trench with a width equal to the diameter of the fiber roll.

1. Drive stakes at the ends of each fiber roll and spaced 4 ft maximum on center.
2. Use wood stakes with a nominal classification of  $\frac{3}{4}$ " by  $\frac{3}{4}$ " and minimum length of 24".

If more than one fiber roll is placed in a row, the rolls should be overlapped, not abutted. For fiber rolls being placed on a slope, locate rolls on level contours spaced as follows:

1. Slope inclination of 4:1 (H:V) or flatter: Fiber rolls should be placed at a maximum interval of 20 feet.
2. Slope inclination between 4:1 and 2:1 (H:V): Fiber rolls should be placed at a maximum interval of 15 feet. (a closer spacing is more effective)
3. Slope inclination 2:1 (H:V) or greater: Fiber rolls should be placed at a maximum interval of 10 feet. (a closer spacing is more effective)

The ends of the fiber roll shall be turned up slope to prevent runoff from going around the roll.

### **17-04 STABILIZED CONSTRUCTION ENTRANCE / EXIT**

A stabilized construction access is defined by a point of entrance / exit to a construction site that is stabilized to reduce the tracking of mud and dirt onto public roads by construction vehicles. Where traffic will be entering or leaving the construction site, a stabilized construction entrance shall be used. The entrance shall be constructed of a pad of aggregate underlain with filter cloth located at any point where traffic

will be entering or leaving the site to or from a public right of way, street, alley, sidewalk, or parking area.

**17-04a Design and Layout:** The stabilized entrance shall be constructed on level ground where possible. It should be constructed with 3" to 6" diameter crushed stones at a minimum depth of 12" or as recommended by the soils engineer. The length of the entrance / exit shall be 50 ft minimum and 15 ft minimum width. Always limit the points of entrance / exit to the construction site and require that all employees, subcontractors, and suppliers utilize the stabilized construction access.

## **17-05 CONCRETE WASHOUT AREAS**

A concrete washout shall be used to prevent and reduce the discharge of pollutants to storm water from concrete waste. An area onsite shall be designated for performing washout activities.

**17-05a Onsite Temporary Concrete Washout Facility:** Temporary concrete washout facilities shall be located a minimum of 50 feet from storm drain inlets, open drainage facilities, and watercourses. Each facility should be located away from construction traffic or access areas to prevent disturbance or tracking.

A sign should be installed adjacent to each washout facility to inform concrete equipment operators to utilize the proper facilities.

Temporary concrete washout facilities should be constructed above grade or below grade at the option of the contractor. Temporary concrete washout facilities should be constructed and maintained in sufficient quantity and size to contain all liquid and concrete waste generated by washout operations.

Once concrete wastes are washed into the designated area and allowed to harden, the concrete should be broken up, removed, and disposed of. Dispose of hardened concrete on a regular basis. Holes or depressions or other ground disturbances caused by the removal of the temporary concrete washout facilities should be backfilled and repaired.

Temporary concrete washout facilities (Type Above Grade & Type Below Grade) should be constructed as shown on the details in the standard specifications or in the CASQA BMP Handbook.

## **17-06 STREET SWEEPING AND VACUUMING**

Street sweeping and vacuuming shall be performed on a daily basis where construction traffic is accessing the public right of way. Visible sediment tacking should be swept or vacuumed on a daily basis. Kick brooms or sweeper attachments are not allowed. All sweepers must have a vacuum system.

## **17-07 PORTA POTTY LOCATIONS**

**17-07a Storage and Disposal Procedures:** Temporary sanitary facilities should be located away from drainage facilities, watercourses, and from traffic circulation. Sanitary facilities shall be located a minimum of 50 feet from any drainage inlet, manhole, swale, or basin. When subjected to high winds or risk of high winds, temporary sanitary facilities should be secured to prevent overturning. No wastewater shall be discharged or buried within the project site. Sanitary and septic facilities should be maintained in good working order by a licensed service. Regular waste collection by a licensed hauler should be arranged before facilities overflow.

## **17-08 SILT FENCING**

Silt fencing is a permeable fabric designed to intercept and slow flow of sediment-laden sheet flow runoff.

**17-08a Material Requirements:** Silt fencing shall be woven polypropylene fabric with a minimum width of 36 inches. The fabric shall conform to the requirements of ASTM (American Society for Testing and Materials) designation D4632 and have an integral reinforcement layer. The permittivity of the fabric shall be between  $0.1 \text{ sec}^{-1}$  and  $0.15 \text{ sec}^{-1}$  in conformance with ASTM designation D4491.

**17-08b Stake Requirements:** Wood stakes shall be commercial quality lumber and shall be 2 inches by 2 inches, and 4 feet in length. The stakes shall be free from decay, splits, or cracks longer than the thickness of the stakes. Maximum stake spacing is 8 feet.

**17-08c Design and Layout:** The maximum length of slope draining to any point shall be 200 feet. The slope of area draining to the silt fence shall be less than 1:1 VH. For slopes steeper than 1:2 that contain large numbers of rocks or dirt clods that tend to dislodge additional protection may be necessary. For any one segment of silt fencing, the drainage area should not exceed 1/3 acre.

**17-08d Installation Requirements:** When installing silt fencing, the contractor shall "Key-in" the bottom of the silt fence a minimum of 12 inches, 6 inches down, and 6 inches out. All silt fencing shall be constructed with a set-back of at least 3 feet from the toe of slope.

## APPENDIX A

### DEFINITIONS

---

---

**Air-Gap Separation** - A physical break between a supply pipe and a receiving vessel. The air gap should be at least double the diameter of the supply pipe, measured vertically above the top rim of the vessel, and in no case less than one inch.

**ANSI** - American National Standards Institute.

**Applicant** - Any person or authorized representative, firm, corporation, association, or agency who applies for non-potable water service. The successful applicant becomes a user.

**Application Rate** - The rate at which water is applied to an irrigation or construction area, expressed in inches per hour.

**Approved Use Area** - A site with well defined boundaries, designated in a user permit issued by the City, to receive non-potable water for an approved use and in conformance with regulations of all applicable regulatory agencies.

**ASTM** - American Standards for Testing Materials.

**Automatic System** - Automatic controllers, valves, and associated equipment required for the programming of effective water application rates when using non-potable water.

**AWWA** - American Water Works Association.

**City** - The distributor of the non-potable water.

**City Supervisor** - Person designated by the City who is responsible for operation and maintenance of the non-potable water distributed system, prevention of cross-connection, and surveillance of all non-potable water users.

**Color Codes** - Colors specified by the City to differentiate various types of facilities (i.e.: potable from non-potable water systems).

**Contractor** - A person, persons, or firm entering into a legal agreement with the City or applicant for the performance of work on any portion of facilities subject to these guidelines.

**Cross-Connection** - An unprotected actual or potential connection between a potable water system used to supply water for drinking purposes and any source or system containing unapproved water. Bypass arrangements, jumper connections, removable sections, swivel or

changeover devices, or other devices through which backflow could occur, should be considered to be cross-connections.

**Gray Water** - Wastewater other than toilet and/or urinal wastes which is reused on the premise.

**Infiltration Rate** - The rate at which soil will accept water.

**Non-potable Water** - Any water, including reclaimed water, not meeting current potable water standards. Water which is suitable for beneficial uses excluding human consumption. Specifically excluded from this definition is "Gray Water".

**Non-potable Water System** - A system serving water that is considered unsafe or aesthetically unacceptable or human consumption.

**Offsite Facilities** - City's non-potable water facilities up to and including the water meter.

**On-site Facilities** - User's non-potable water facilities downstream from the water meter.

**POC** - Point of Connection

**Ponding** - Retention of piped water on the surface of the ground or man-made surface for a period of time following the cessation of an approved reclaimed water use activity such that potential hazard to the public health may result.

**Potable Water** - Water which is pure and wholesome, will not endanger the lives or health of human beings, and conforms to the quality standards of Federal, State and local authorities.

**Potable Water System** - System serving potable water.

**PVC Pipe** - Polyvinyl chloride pipe.

**Reclaimed Water** - Water which, as a result of treatment of domestic wastewater, is suitable for a direct beneficial use or a controlled use that would not otherwise occur. Specifically excluded from this definition is "Gray Water".

**Record (as-built) Drawings** - Engineering plans that correctly show (1) all on-site and offsite non-potable water facilities as constructed or modified and (2) all potable water lines and sewage lines.

**Reduced Pressure Principle Backflow Prevention Device (RPPD)** - A backflow preventer incorporating not less than two check valves, an automatically operated differential relief valve located between the two check valves, a tightly closing shut-off valve on each side of the check valve assembly, and equipped with necessary test cocks for testing.

- Regulatory Agency** - Those public agencies legally constituted by the State to protect health and water quality.
- Runoff** - Flow of water along the surface of the ground or other natural or manmade surfaces, including but not limited to pedestrian walkways, streets, playground surfaces, and grassy slopes.
- Sealing Water** - Independent water supplies to pump seals which provide sufficient sealing pressure and priming.
- Spray Irrigation** - Application of water for irrigation by spraying.
- Unauthorized Discharge** - Any release of non-potable water that violates the regulations of the agency or any and all applicable Federal, State, or local statutes, regulations, ordinances, and contracts.
- User (customer)** - Any person, firm, corporation, association or agency receiving non-potable water service.
- User Permit** - A permit issued by the City to the applicant after the satisfactory completion of the procedure set forth in these guidelines. This permit constitutes a service agreement which legally binds the user to all applicable regulatory agencies' requirements.
- User Supervisor** - A qualified person designated by the user (customer) and approved by the City who should be responsible for the installation, operation, and maintenance of the user on-site facilities, the prevention of cross-connection, and compliance with the local agency.
- Windblown Spray** - Dispersed, airborne particles of water capable of being transmitted through the air to a location other than that for which the direct application of reclaimed water is approved.



## **APPENDIX B**

### **ADMINISTRATIVE PROCEDURES**

#### **B-01 GENERAL**

The following describes the required procedure for an applicant to obtain service from the city for the proposed service area and to obtain approval for construction of facilities to be dedicated for operation and maintenance by the City.

#### **B-02 PRELIMINARY INVESTIGATION**

The user should meet with the City at the earliest possible date to determine whether the property to be developed is within the City's non-potable service boundaries. At this time, the availability of existing facilities should also be reviewed (It should be the responsibility of the user to request confirmation that the City has sufficient capacity). In some areas, a preliminary feasibility investigation and report may be necessary. The user should file directly with the City supervisor, a map describing the area to be served, the tentative tract map, plot plans, preliminary prints of streets, construction plans and such other materials as the City may request for use in its investigation.

#### **B-03 SERVICE APPLICATION**

An application for non-potable water service should be submitted to the City only after the City has received a report of preliminary investigation accepting the feasibility of the proposed service. Approval for service shall be indicated by the City by issuing a user permit to the applicant. The user permit shall come into force only after construction of the subject project is completed and final acceptance has been granted by the City and approval for service start-up given.

The application for non-potable water service should be made in writing and signed by the user, who may be the owner or authorized representative. The application form is furnished by the City and requests information concerning the applicant's company, the user's relationship to the subject property as legal owner, tenant, or lessee; the type of non-potable water use; a boundary description of the property to be served; the purpose for which the properties are to be served; the purpose for which the property is to be used; the estimated consumption of non-potable water; the designation of user supervisor; and any special conditions for service pursuant to these guidelines. Certain technical information derived from the design and peculiar to the type of non-potable water use may also be requested.

Upon receipt of an application, the City will review the application and make such investigation as deemed necessary. The City may prescribe specific requirements in writing to the user as to the design of the facilities, the manner of construction, the method of operations and the conditions of service. An evaluation should be performed which will establish that all information included on the form is consistent with the guidelines and the applicable requirements of the regulatory agencies.

## **B-04 CONTROL OF DESIGN**

The City shall approve all non-potable water system designs.

**B-04a Offsite Facilities:** The design of any portion of the offsite facilities and the preparation of plans and construction specifications shall be approved by an engineer registered by the State.

It is the responsibility of the user to meet with the City in order to determine what requirements, if any, there may be for phasing stages of non-potable water distribution line installation. It also is the responsibility of the user to coordinate its activities with those of the City in the development of mains for the non-potable water distribution system.

The City reserves the right to determine the size of the service connection and also the kind and size of all appurtenances to the service including pressure reducing valve and water meter. The City will make the service connection and install the meter with its own personnel or through contracted labor. All pressure reducing valves are to be installed and maintained by the user.

Other design requirements for offsite facilities are found in the City's design specifications. AWWA, ANSI and ASTM Standards are to be used for all materials.

**B-04b On-site Facilities:** The design of the on-site facilities and the preparation of plans and construction specifications are the responsibility of a landscape architect or engineer registered with the State.

In those areas where water is not immediately available for use when the design area is ready for construction, the on-site facilities should nevertheless be designed to use non-potable water. Provisions should be made and these guidelines followed to allow for connection to the non-potable water system when it becomes available. In the interim, potable water should be supplied to the on-site facilities through an approved temporary potable water connection. An approved reduced pressure backflow prevention device is required as long as the on-site facility is using potable water. This device shall be provided and installed by the user to the satisfaction of the City.

Only when the City makes the connection to the non-potable water system can the user remove the backflow preventer. All points of connection to the City's offsite facilities are to be determined by the City.

The on-site facilities are designed to meet the peak moisture demand of all plant materials used within the design area and to apply irrigation water in a manner compatible with the infiltration rates of the soil types within the approved use area. Infiltration rates are to be included with the design. The irrigation system should be designed to prevent discharge onto areas which are not approved for use and to prevent ponding and/or runoff.

Other design requirements for on-site facilities can be found in the City's design specifications.

**B-04c Construction Water Facilities:** Service connections for the construction use of non-potable water are provided by the City at locations convenient to the user but at the discretion of the City. The service includes a valved connection to a non-potable water distribution main and a water meter whose capacity is determined by the City from information supplied by the user in the user permit application. The City will make the connection to the main and install the meter.

**B-04d Conversion of Existing Facilities to Non-potable Water:** All facilities converted from a potable to a non-potable facility shall conform to these guidelines. The facilities to be converted should be investigated in detail, including review of any record drawings, preparation of required reports and determinations by the City of measures necessary to bring the system into full compliance with guidelines.

The plans and specifications for the converted shall be submitted to and reviewed by the City.

## **B-05 EXAMPLE DESIGN AND INSPECTION CONTROL PROCEDURES**

The following design and inspection control procedures should be considered as a guideline.

**B-05a Master Development Plan:** Before the City can issue a preliminary will-serve letter for a proposed development, the user should submit two sets of tentative master development plans showing the plan of the proposed non-potable water system for review and approval by the City. The City, when reviewing a preliminary non-potable water system design for the planned development, will take into consideration the following:

- (1) Existing non-potable water transmission main locations and sizes.
- (2) City's non-potable water master development plan.
- (3) City's design specifications.
- (4) Applicant's irrigation requirements.

The City will return the "red-lined" copy of the reviewed master development plan to the applicant showing any corrections and/or comments. The master development plan, as corrected, shall then be considered approved by the City; however, the user must make the corrections noted and resubmit two sets of the revised plans to the City.

- B-05b Improvement Plans:** The user shall submit to the City two sets of each of offsite and on-site (individual tract) non-potable water system improvement plans for review and approval. The City will return one "red-lined" set of the reviewed improvement plans to the user showing any corrections and/or comments. The user shall make the corrections noted, respond to the City's comments appropriately and provide the City with copies of the required easements to the City if recorded by separate instrument. Upon completing these requirements to the satisfaction of the City, the user shall bring the original drawings to the City for signature of approval. Four sets of completely signed and approved non-potable water system improvement plans shall be furnished to the City at least two working days before the required pre-construction conference prior to commencing work.
- B-05c Pre-construction Conference:** A pre-construction conference should be held at least 24 hours before starting construction. The contractor's working foreman and/or job superintendent, the user's tract superintendent and the City's engineer and inspector should be present. The purpose of this meeting is to resolve any questions on City specification requirements to obtain the contractor's construction procedural schedule, and to disclose and discuss any known circumstances that might affect job installation.
- B-05d Inspection of Work:** All work will be subject to inspection by the City and shall be left open and uncovered until approved by the City.
- B-05e City Authority:** The City shall at all times have access to the work during construction and be provided reasonable assistance for ascertaining full knowledge regarding the process, workmanship and character of materials used and employed in the work. No pipe, fittings or other materials should be installed or backfilled until inspected and approved by the City. The contractor shall give due notice to the City inspector in advance of backfilling as well as all other inspection phases so that proper inspection may be provided. Inspection of the work shall not relieve the contractor any obligations to complete the work as prescribed by the City. Defective work shall be made good before any testing of final inspection will be permitted. Any defective work or unsuitable materials may be rejected notwithstanding the fact that such defective work and unsuitable materials had been previously overlooked by the City. The City has the authority to suspend the work wholly or in part for such time as it may deem necessary due to the failure of the contractor to carry out orders given by the City inspector or to perform any provisions of the plans and specifications. The contractor shall immediately comply with the written order of the City to suspend the work wholly or in part. The work should be resumed only when methods or defective work are corrected as ordered and approved in writing by the City.
- B-05f Final Inspection:** Before final acceptance, the City inspector, accompanied by the contractor's superintendent or foreman, will make a final inspection of all work.

## **B-06 GRANTING OF EASEMENT TO THE CITY**

Prior to the City's signing the improvement plans for the non-potable water facilities required to serve the area for which user has requested service from the City, the user should have prepared, processed, granted recorded and conveyed to the City all easements required by the City for operating, maintaining, modifying or replacing the facilities. All easements shall be recorded with the local county recorder.

## **B-07 DEDICATION OF OFF-SITE FACILITIES TO CITY**

Upon completion of off-site facilities and final inspection of all work, the user shall file a request for dedication to and formal acceptance of the facilities by the City.

## **B-08 GUARANTEES**

The user is responsible for any and all repairs and replacement to City facilities for a period of one year from the date of acceptance without expense whatsoever to the City. In the event the user fails to comply with the aforementioned conditions, the City is authorized to proceed to have the defects repaired and made good at the expense of the user who will be required to pay the cost and charges including attorney fees and other incidental costs involved thereof, immediately upon demand.

## **B-09 ISSUING OF USER PERMIT (SERVICE AGREEMENT)**

The user permit issued by the City to the user constitutes a legally binding service agreement between the two parties. The user permit incorporates these guidelines and any additional requirements prescribed by the City to ensure continued operation of the non-potable water system or to protect the public health. The City will assign an accounting number to each permit issued.

## **B-10 ESTABLISHING SERVICE CONNECTIONS**

Following the completion of construction and/or installation of the non-potable water facilities and the submittal and approval of record documents accompanied by all requisite fees for installation and connection, the City will install the service connection.

## **B-11 SERVICE START UP**

Following final acceptance of the project by the City, the user should request service start-up. The City, upon receipt of such request will set the meter and turn on the service.

This Page  
Intentionally Left Blank

# CITY OF RIPON STANDARD DRAWINGS TABLE OF CONTENTS

## **General**

General Notes .....	G-1
General Notes .....	G-2
General Notes .....	G-3
Subdivision Design Standards.....	G-4
Improvement Plan Standards.....	G-5
Pipe Materials .....	G-6
Large Diameter Sewer and Storm Drain Pipe .....	G-7
Drafting Standards .....	G-8
Drafting Standards .....	G-9
Drafting Standards .....	G-10
Signature Blocks .....	G-11
Intentionally Left Blank .....	G-12

## **Streets**

Street Design Standards .....	ST-1
Street Design Standards .....	ST-2
Street Design Standards .....	ST-3
All Weather Roads .....	ST-4
Trip Generation Factors .....	ST-5
Structural Concrete Pavers and Pavement Design Chart .....	ST-6
Street Section Chart and Street Design Standards .....	ST-7
Street Design Standards .....	ST-8
Concrete Street Paver Standard .....	ST-8a
140' Major Arterial Street Section.....	ST-9
102' and 50' Street Sections.....	ST-10
82' Street Section .....	ST-10a
74' and 60' Street Sections.....	ST-11
Alternate Cul-De-Sac Detail .....	ST-12
Standard Cul-De-Sac Detail .....	ST-13
Extended Standard Cul-De-Sac Detail .....	ST-13a
Cul-De-Sac Island Detail .....	ST-13b
Special Residential Parking.....	ST-14
Special Residential Parking.....	ST-15
Special Residential Parking.....	ST-16
Alignment for 90° Plus Street Intersections .....	ST-17
School Area Pavement Legends .....	ST-18
Crosswalk / Stop Bar Placement.....	ST-19
Concrete Curb, Gutter & Sidewalk Standards .....	ST-20
6" Vertical Curb, Gutter and Sidewalk.....	ST-21

4-1/2" Drive-Over Curb, Gutter and Sidewalk .....	ST-21a
Type "C", "D", and "E" Curb and Gutter.....	ST-21b
Class II Bicycle Path and Gutter Pan .....	ST-21c
Location of Weakened Plane Joints .....	ST-22
Standard Residential Driveway with Vertical Curb and Detached Sidewalk.....	ST-23
Standard Residential/Commercial Driveway with Vertical Curb and Attached Sidewalk .....	ST-23a
Special Driveway Detail Drive-Over Curb Approach with 6" Vertical Curb.....	ST-23b
140' Major Arterial Commercial Driveway with Detached Sidewalk.....	ST-24
102' Minor Arterial Commercial Driveway with Detached Sidewalk.....	ST-24a
82' and 74' Street R.O.W. Commercial Driveway with Detached Sidewalk.....	ST-24b
Type 1 Commercial Driveway with Attached Sidewalk.....	ST-24c
Type 2 Commercial Driveway with Attached Sidewalk.....	ST-24d
Intentionally Left Blank .....	ST-25
Typical Wheelchair Ramp at Intersections .....	ST-26
Residential Wheelchair Ramp Detail for Detached Sidewalk .....	ST-26a
Residential Wheelchair Ramp Detail for Detached Sidewalk to Attached Sidewalk .....	ST-26b
Typical Wheelchair Ramp Detail for Commercial/Industrial Applications .....	ST-27
Commercial/Industrial Wheelchair Ramp Detail for 140' Right-of-Way .....	ST-27a
Commercial/Industrial Wheelchair Ramp Detail for 102' Right-of-Way .....	ST-27b
Commercial/Industrial Wheelchair Ramp Detail for 82' and 74' Right-of-Way.....	ST-27c
Typical Mid Block Wheelchair Ramp Detail with Detached Sidewalk .....	ST-28
Typical Mid Block Wheelchair Ramp Detail with Attached Sidewalk .....	ST-28a
Wheelchair Ramp Groove and Lip Detail and Raised Truncated Dome.....	ST-29
Raised Paver Intersection Plan View Detail .....	ST-30
Raised Intersection\Paver Transition Section View Detail.....	ST-30a
140' Right-of-Way Roundabout Geometrics.....	ST-31
102' Right-of-Way Roundabout Geometrics.....	ST-32
84' Right-of-Way Roundabout Geometrics.....	ST-33

## **Water**

General Requirements for Water Services.....	W-1
General Requirements for Water Services.....	W-2
Water Line Design Criteria .....	W-3
Criteria for Separation of Water Mains from SS/SD Lines.....	W-4
Criteria for Separation of Water Mains from SS/SD Lines.....	W-5
Criteria for Separation of Water Mains from SS/SD Lines.....	W-6
Criteria for the Separation of Water Mains from SS/SD Lines – Case 1 .....	W-7
Criteria for the Separation of Water Mains from SS/SD Lines – Case 2 .....	W-7a
Water Design Data.....	W-8
Tracer Wire Installation Detail .....	W-9
Fire Lane Details .....	W-10
Fire Lane Notes.....	W-10a
Valve Box Details .....	W-11
Thrust Block Details .....	W-12



1-1/2" and 2" Metered Water Service Installation .....	W-13
1" Metered Water Service Installation .....	W-14
Remote Meter Read Installation .....	W-15
Permanent and Temporary Blowoff Details .....	W-16
Intentionally Left Blank .....	W-17
Intentionally Left Blank .....	W-18
Reduced Pressure Principle Backflow Prevention Assembly for 1" to 2-1/2" .....	W-19
Reduced Pressure Principle Backflow Prevention Assembly for 3" and Larger ....	W-20
Fire Hydrant Spacing.....	W-21
Fire Hydrant at Back of Curb in Parkway Planter .....	W-22
Fire Hydrant Notes .....	W-22a
Fire Hydrant with Vertical Curb and Attached Sidewalk .....	W-23
Fire Hydrant with Drive-Over Curb and Attached Sidewalk.....	W-23a
Fire Sprinkler Connection Located More than 30 Feet from Nearest Fire Hydrant.....	W-24
Fire Sprinkler Connection Located within 30 Feet from Nearest Fire Hydrant.....	W-25
Water Sampling Station Detail .....	W-26
Typical Offset Unit.....	W-27
Air and Vacuum Release Valve Detail.....	W-28
Waterline Hot Tap Detail .....	W-29
Intentionally Left Blank .....	W-30

## **Storm Drain**

Criteria for Design of Storm Drain Facilities .....	SD-1
Criteria for Design of Storm Drain Facilities .....	SD-2
Rainfall Intensity Curves.....	SD-3
Rainfall Intensity Curves.....	SD-3a
Rainfall Intensity Curves.....	SD-3b
Rainfall Intensity Curves.....	SD-3c
Inlet Time .....	SD-4
Storm Drain Design Sheet.....	SD-5
Storm Drain Data .....	SD-6
Frame and Grate, Type 2 Curb Inlet Catch Basin .....	SD-7
Type 2 Curb Inlet Catch Basin .....	SD-7a
Frame and Grate, Type 1 Curb Inlet Catch Basin .....	SD-8
24" Round Curb Inlet Catch Basin Detail .....	SD-8a
24" Square Curb Inlet Catch Basin Detail .....	SD-8b
Parking Lot Catch Basin.....	SD-9
Type 1 Standard Storm Manhole .....	SD-10
Storm Drain Plug.....	SD-10a
Separation Manhole Detail .....	SD-11
Type 2 Manhole for Pipe 36" Diameter and Larger .....	SD-12
Type 2 Manhole for Pipe 36" Diameter and Larger .....	SD-13
Typical Sand and Oil Trap.....	SD-14
Storm Drain Manhole Frame and Cover.....	SD-15

## **Sewer**

Criteria for Design of Sanitary Sewer Facilities .....	S-1
Sanitary Sewer Design Data .....	S-2
Lift Station Design Data.....	S-3
Sanitary Sewer Design Sheet .....	S-4
Sanitary Sewer Data .....	S-5
Standard Sanitary Sewer Manhole.....	S-6
Sanitary Sewer Drop Manhole (Exterior Piping) .....	S-7
Sanitary Sewer Manhole Frame and Cover .....	S-8
Lamphole and Lamphole Ring and Cover Detail .....	S-9
Cleanout Riser .....	S-10
House Lateral Detail.....	S-11
Typical Grease Trap.....	S-12
Sewer Stack House Lateral.....	S-13
Intentionally Left Blank .....	S-14

## **Utilities**

Typical Location of Underground Utilities .....	U-1
Intentionally Left Blank .....	U-2
Typical Deep Trench Backfill.....	U-3
Jack and Boring .....	U-4
Concrete Saddle Detail .....	U-5
Existing Street Trench Section .....	U-6
Existing Street Trench Section for Pipe 4" and Smaller .....	U-7
Pot Hole / Bore Pit (Existing Street) Additional Pavement Restoration .....	U-8
Location of Underground Utilities .....	U-9
Intentionally Left Blank .....	U-10

## **Lighting**

Street and Parking Lot Lighting .....	L-1
Street and Parking Lot Lighting .....	L-2
Street and Parking Lot Lighting Pole and Base Standards.....	L-3
Street Light Pole Base Placement.....	L-3a
Locations of 55 and 85 Watt Lights .....	L-4
Locations of 165 Watt Lights .....	L-5

## **Irrigation**

Typical Tree Well Irrigation System Requirements.....	IRR-1
Typical Tree Well Irrigation System Requirements.....	IRR-2
Typical Tree Well Irrigation System Requirements.....	IRR-3
Typical Tree Well Installation .....	IRR-4
Typical Tree Well Detail .....	IRR-5
Intentionally Left Blank .....	IRR-6

## **Miscellaneous**

Survey Monument Marker .....	M-1
Special Monument Installation .....	M-2
Survey Monument .....	M-3
Typical Interior Lot Grading Detail .....	M-4a
Typical Corner Lot Grading Detail .....	M-4b
Intentionally Left Blank .....	M-5
Adjusting Street Facilities to Grade .....	M-6
Street Name Sign .....	M-7
Street Name Sign Location .....	M-8
Lane Reduction Transition .....	M-9
Barricades for Terminating Streets .....	M-10
Sound Wall Design Criteria .....	M-11
Sound Walls .....	M-12
Property Line Retaining Wall .....	M-13
Chain Link Fence Standards .....	M-14
Off Street Parking Standards .....	M-15
Off Street Parking Standards .....	M-16
Intentionally Left Blank .....	M-17
10' x 12' Concrete Block Refuse Container Enclosure .....	M-18
Typical Expansion Joint and Valley Gutter .....	M-19
Gate Rollers Detail .....	M-20

## **Storm Water Pollution Prevention**

General Storm Water Pollution Prevention Notes .....	SWPP-1
Storm Drain Inlet Protection .....	SWPP-2
Storm Drain Marker .....	SWPP-3
On Grade Temporary Concrete Washout Facility .....	SWPP-4a
Below Grade Temporary Concrete Washout Facility .....	SWPP-4b
Stabilized Construction Entrance .....	SWPP-5
Field Inlet / Manhole Protection .....	SWPP-6

This Page  
Intentionally Left Blank

1. Contractor agrees that he shall assume sole and complete responsibility for job site conditions during the course of construction of this project, including safety of all persons and property, that this requirement shall apply continuously and not be limited to normal working hours; and that the contractor shall defend, indemnify and hold the Owner, Engineer, and the City harmless from any and all liability real or alleged, in connection with the performance of work on this project excepting for liability arising from the sole negligence of the Owner of the Engineer.
2. Unless otherwise stated, all stations indicated on the improvement plans are referenced to the centerline of the street. All stations on the curbs are perpendicular to or radially opposite centerline stations, unless otherwise noted.
3. It is the contractor's responsibility to verify the location of all existing facilities.
4. The contractor shall be held responsible for any field changes made without written authorization from the City Engineer.
5. The contractor shall provide all lights, signs, barricades, flagmen or other devices necessary to provide for public safety in accordance with the current issue of the Manual of Traffic Controls Warning Signs, Lights and Devices for use in performance of work upon highways published by the State of California business and transportation agency.
6. Contractor shall be responsible for adequately marking the installed location of all sanitary and water services (stamped with an "S", "W" and "NP" respectively) at the same time of installation. Contractor shall remove all existing berms, structures and barricades, paving and or oil screening within specific areas indicated to be improved.
7. The office of the city engineer shall be notified at least 24 hours in advance of any work.
8. All materials, workmanship, and construction shall be done in accordance with the requirements of the City of Ripon, Standard Specifications and Standard Details, and the latest edition of the State of California, Department of Transportation, Standard Specifications.
9. Electric, telephone, and cable tv underground trenching work shall be completed prior to construction of the curb, gutter, sidewalk, and paving. All utility boxes, transformers, etc. shall be located below ground.
10. If required, the contractor shall determine the proper well placements to adequately dewater the area for trenching.

NO.	REVISED	BY	<b>General Notes</b>	APPROVED
				
				CITY ENGINEER RCE-28191
				DATE: 2-2-99
DRAWN BY: MATT			<b>CITY OF RIPON</b>	STANDARD NO. <b>G-1</b>
CHECKED BY: DJR				
V:\25_City of Ripon Standards\Standard Specifications\Drawings\Generalg-1.dwg				

11. The City of Ripon or associated utility company and residences to be affected shall be notified immediately upon any utility service disruption other than specified on these improvement plans and a 24 hour notice shall be given for any planned disruption.
12. Dust shall be controlled per section 10 of the State of California, Department of Transportation, Standard Specifications and the City of Ripon's Standard Specifications and Standard Details.
13. Lots shall be graded to establish identical elevations (attempt to match grades) with adjacent lots and surrounding property unless otherwise approved by the City Engineer.
14. An encroachment permit shall be obtained from the City of Ripon, Engineering Department, or any other applicable agencies prior to commencement of work within existing City right-of-way.
15. Street signs, traffic control signs, and pavement markings shall be provided and installed by the contractor at locations established by the City Engineer.
16. The contractor shall secure a trench permit from the California Division of Industrial safety prior to excavation of any trench over five feet in depth.
17. Asphalt concrete shall be placed only when the atmospheric temperature is above 50° F and rising.
18. All street lighting shall be constructed by and at a cost to the developer. After completing a five day burn test, ownership of the street lights is then transferred to the City of Ripon Lighting District (LS-2C Schedule).
19. The contractor shall verify locations of all existing underground utilities and shall contact the respective utility companies prior to commencement of work. The contractor shall be responsible for the location and preservation of all such facilities in the area of construction and shall notify utilities forty-eight (48) hours in advance of any construction.
20. The contractor is responsible for coordination of the removal or relocation of all existing utilities with respective utility companies.
21. The contractor is to provide compacted building pads at the elevations shown on the grading plan  $\pm 0.10'$ .
22. All sanitary sewer service laterals shall be extended past the property line and plugged. A cleanout shall be installed at the property line.

NO.	REVISED	BY	<b>General Notes</b>	APPROVED
				
				CITY ENGINEER RCE-28191
				DATE: 2-2-99
DRAWN BY: MATT			<b>CITY OF RIPON</b>	STANDARD NO. <b>G-2</b>
CHECKED BY: DJR				
V:\25_City of Ripon Standards\Standard Specifications\Drawings\General\g-2.dwg				

23. Manhole castings and covers shall be adjusted to final grades by the paving contractor after street improvements are completed.
24. All water lines shall be tested and disinfected in compliance with the requirements of the City of Ripon's Standard Specifications and Standard Details, prior to final acceptance.
25. After construction of all improvements, the Engineer shall submit one set of 3 mil. Mylar reproducible "record drawing" plans and an AutoCAD File 2000 or newer on a CD, to the City of Ripon's Engineering Department. Final invert elevations for sewer and storm drain lines that are to be extended for future construction shall also be shown on the "record drawing" plans.
26. All trenches on major and collector streets and cross trenches on all streets shall be paved with temporary paving the same day the pavement is cut and removed.
27. The Contractor shall provide the City with a certificate signed by a registered civil engineer stating that all building pad elevations are in conformance with the approved grading plan. All elevations shall have a tolerance of  $\pm 0.10'$ .
28. Meter boxes and meter setters will be set on the water service lines at locations approved by the City Engineer.
29. The contractor shall perform testing of sewers according to the City of Ripon's Standard Specifications and Standard Details.
30. All sewer and storm lines will be plugged at each manhole and catch basin once constructed. Sewer and storm plugs shall be removed after paving in public right-of-way.
31. All public right-of-way improvements must be complete prior to final acceptance.

NO.	REVISED	BY	<b>General Notes</b>	APPROVED
				
				CITY ENGINEER RCE-28191
DRAWN BY: MATT			DATE: 2-2-99	
CHECKED BY: DJR			<b>CITY OF RIPON</b>	STANDARD NO. <b>G-3</b>
V:\25_City of Ripon Standards\Standard Specifications\Drawings\Generalg-3.dwg				

Subdivision Design Standards

**Blocks:**

Factors Governing Dimensions: Block length and width or acreage within bounding roads shall be such as to accommodate the size of lot required in the area by the zoning plan and to provide for convenient access circulation and safety of street traffic. Block lengths shall not exceed 1300 feet. Pedestrian walkways may be permitted in locations deemed necessary for public health, convenience and necessity.

**Lots:**

Residential: Residential lots shall have a width and length that conforms to the City of Ripon Zoning Regulations. On cul-de-sac and curvilinear streets the minimum width shall be measured along the arc length at the property line. Lots shall have a minimum area conforming to the standards set forth in the zoning plan.

Location: All residential lots shall abut by their full frontage on a publicly dedicated street. Double frontage lots of less than 200 feet in depth shall not be permitted except where access rights to one frontage has been dedicated to the City.

Lot Lines: In general side lot lines shall be at right angles to straight street lines or radial to curved street lines.

Uninhabitable Lots: Lots or land subject to flooding, or deemed by the city council to be uninhabitable, shall not be platted for residential occupancy, nor for such other uses as may increase danger to health, life, or property, or aggravate the flood hazard unless the flood hazard or other condition making the lots uninhabitable is corrected to the satisfaction of the City Engineer. Any land within the subdivision which is subject to flooding or other uninhabitable conditions shall be set aside for such uses as shall not be endangered by periodic or occasional inundation or shall not produce unsatisfactory living conditions.

Lot drainage: Each lot shall be designed, graded and maintained to provide proper drainage without ponding or causing severe soil erosion. Drainage from each lot shall be confined wholly to that lot until it is discharged upon an abutting street. A waiver of these provisions shall occur only where other alternate drainage facilities and recorded easements are provided, the responsibility for maintenance of such facilities is clearly established, and such alternate plan is approved in writing by the City Engineer. Typical lot drainage details shall be shown on the grading plan as part of the improvement plans.

Easements: Easements shall be provided where necessary and of such width as required by the City Engineer. Where a subdivision is adjacent to, abuts, or is traversed by a water course, drainage way, channel, or a stream, there shall be provided a storm water easement or drainage right of way conforming substantially with the lines of such water course, and of such width or construction, or both, as will be adequate for the purpose of maintaining drainage. Reasonable public access shall be provided by easement from public street to a portion of the bank of river or stream bordering or lying within the proposed subdivision.

National pollution discharge elimination system permit: Developer shall obtain necessary NPDES permits, from the State Regulated Water Quality Control Board, and comply with its requirements.

NO.	REVISED	BY	<b>Subdivision Design Standards</b>	APPROVED
				 CITY ENGINEER RCE-28191
				DATE: 2-2-99
DRAWN BY: MATT			<b>CITY OF RIPON</b>	STANDARD NO. <b>G-4</b>
CHECKED BY: DJR				
V:\25_City of Ripon Standards\Standard Specifications\Drawings\General\g-4.dwg				



Improvement Plan Standards

All improvement plans shall conform to the following requirements and include the following detailed information:

1. All streets and cul-de-sacs shall show centerline stationing. Stationing shall be tied or referenced to existing monuments or other permanent reference points. Equations shall be shown at all centerline intersections.
2. Centerline monuments, in accordance with standard dwg M-3 shall be set at the beginning and end of each curve, at all intersections, ends of cul-de-sacs and on tangents exceeding 800 feet in length. Tangent monuments shall be equally spaced. All monuments shall be set based on the California coordinate system Zone No. 3.
3. Street plans shall show location of underground sanitary sewer, storm drain, domestic and non-potable water lines. Location of lines shall be referenced to street centerline manholes, catch basins, tees, valves and any other fittings, together with any angle points in the lines, shall be referenced to the appropriate centerline station.
4. Street plans shall show size and length of pipes between manholes, catch basins and/or valves, where a specific type of pipe is to be installed, such type shall also be indicated.
5. Street plans shall also show type of curb, gutter and sidewalk to be installed. Top of curb elevations at the beginning and end of each curb return, each catch basin and any grade breaks shall be indicated. Grade breaks shall be stationed.
6. Existing utility installations shall be shown as detailed above.
7. Street profile sheets shall show the size, length, slope, type and elevation of all existing and proposed sanitary sewer, storm sewer, water pipe lines, irrigation, electrical, gas, and telephone lines. Invert elevations at the ends of each pipe, at manholes and catch basins shall also be indicated.
8. Proposed street profiles shall show the existing ground profile and the date at which the profile was taken. Profiles of the existing and proposed curb and gutters shall be shown. Proposed profiles shall show the slope together with the elevations and stationing at each grade break and at the beginning and end of each curb return.
9. Improvement plan standards for street lighting work shall conform to standard dwgs. L-1 thru L-5
10. Horizontal and vertical scales shall be shown on each sheet of improvement plans.
11. All elevations shall be based on the U.S.G.S. datum.
12. A minimum of one bench mark shall be indicated on each sheet of the plans. The bench marks shall have been conveniently located for use in constructing the improvements on that particular sheet.
13. At the conclusion of construction, the engineer who prepared the improvement plans will add to the plans, for City record purposes, construction data based on information compiled and furnished by the engineer, contractors, inspector, and others. On those facilities that will be extended in the future (such as sanitary sewer lines, storm drain lines, water lines and curb and gutter installations), the engineer shall shoot the grades at the end of the facilities and include these "as constructed" grades on the record drawings.

NO.	REVISED	BY	<b>Improvement Plan Standards</b>	APPROVED
				 CITY ENGINEER RCE-28191
				DATE: 2-2-99
DRAWN BY: MATT			<b>CITY OF RIPON</b>	STANDARD NO. <b>G-5</b>
CHECKED BY: DJR				
V:\25_City of Ripon Standards\Standard Specifications\Drawings\General\g-5.dwg				

Approved Materials for Pipes

**Sanitary Sewer Lines**

- 1.) Vitrified clay pipe (extra strength)
- 2.) Ductile iron cement lined, Class 150
- 3.) Polyvinyl Chloride gravity pipe (P.V.C.), SDR-26

**Water Lines**

- 1.) Ductile iron pipe (D.I.P.), Class 150, cement lined inside
- 2.) Polyvinyl chloride pressure pipe (P.V.C.), Class 150, AWWA (C-900)
- 3.) Polyvinyl chloride pipe (P.V.C.), Schedule 40 (for irrigation tree wells only)

**Storm Drain Lines**

- 1.) Reinforced Concrete Pipe, rubber gasketed, Class III (minimum)
- 2.) Non-Reinforced concrete pipe (C.I.P.), (Requires Special City Engineer Approval)
- 3.) Corrugated plastic pipe (Requires Special City Engineer Approval)

Notes

1. Refer to the appropriate section of the Standard Specifications for approved pipe classifications.
2. All materials to be approved by the City Engineer.

NO.	REVISED	BY	<b>Pipe Materials</b>	APPROVED
				 CITY ENGINEER RCE-28191
				DATE: 2-2-99
DRAWN BY: MATT			<b>CITY OF RIPON</b>	STANDARD NO. <b>G-6</b>
CHECKED BY: DJR				
V:\25_City of Ripon Standards\Standard Specifications\Drawings\General\g-6.dwg				

Installation Specifications for  
Sewer and Storm Drain Pipe  
And  
Minimum Cover Requirements for all  
Sewer and Storm Drain Pipe

**Materials**

Pipe materials shall comply with City of Ripon's Standard Specifications and Standard Details.

All sewer and storm drain pipe installed in the City of Ripon shall be visually inspected by means of a closed circuit color television camera at the expense of the contractor. The City shall be provided with one reproducible (DVD format) copy of the video inspection. The quality of the picture shall be to the satisfaction of the City of Ripon, and if unsatisfactory, shall be re-televised. The City of Ripon shall also be provided with a copy of the T.V. inspection log.

**Special Inspector**

A special inspector is required to be present during the installation of all sewer and storm drain pipe (greater than 18" in diameter), except reinforced concrete pipe.

The resume of the special inspector shall be submitted to the City of Ripon, Engineering Department for approval. A daily report shall be completed at the end of each work day by the special inspector, signed, and submitted to the City of Ripon, Engineering Department. The contractor shall be responsible for the cost of providing the special inspector.

Installation of sewer pipe larger than twenty-four inches (24") in diameter shall be reviewed by the State of California Department of Health.

**Installation**

All sewer and storm drain pipe, regardless of size, installed in the traveled way shall have a minimum of thirty inches (30") of cover measured from the top of the pipe to finished grade, if cover over the pipe is less than thirty inches (30"), cement lined ductile iron pipe shall be used in accordance with the City of Ripon's Standard Specifications and Standard Details.

In no case shall the cover be less than eighteen inches (18"). Any sewer or storm drain pipe installed in the traveled way with less than eighteen inches (18") of cover shall be rejected, unless pre-approved by the City Engineer.

NO.	REVISED	BY	<b>Large Diameter Sewer and Storm Drain Pipe</b>	APPROVED
				 CITY ENGINEER RCE-28191
				DATE: 2-2-99
DRAWN BY: MATT			<b>CITY OF RIPON</b>	STANDARD NO. <b>G-7</b>
CHECKED BY: DJR				
V:\25_City of Ripon Standards\Standard Specifications\Drawings\General\g-7.dwg				

# DRAFTING STANDARDS











ALL SUBDIVISION PLANS, CONSTRUCTION DRAWINGS, & PROPERTY PLANS SUBMITTED TO THE CITY FOR CONSIDERATION SHALL CONFORM TO, AND BE PREPARED IN ACCORDANCE WITH THE FOLLOWING STANDARDS:

GENERAL

1. ALL LETTERING, OTHER THAN THAT HEREIN SPECIFIED OR SHOWN BELOW, SHALL BE A MINIMUM OF 0.10 INCH IN HEIGHT USING A NO. 0 RAPIDOGRAPH PEN OR EQUAL. VERTICAL OR SLANTED LETTERING MAY BE USED.

TITLE BLOCK AND OTHER RELATED LETTERING SHALL BE IN ACCORDANCE WITH STANDARD ACCEPTED ENGINEERING PRACTICE, BUT IN NO CASE SHALL THE LETTERING BE LESS THAN 0.10 INCH IN HEIGHT AND USING A NO. 0 RAPIDOGRAPH PEN.

2. SUBDIVISION PLATS











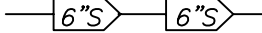
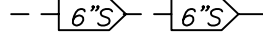
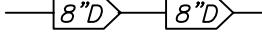
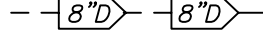

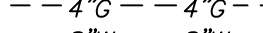

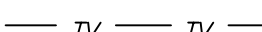





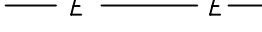
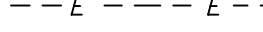
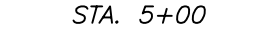











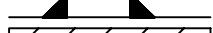
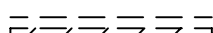

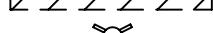







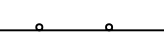

SUBDIVISION OUTLINE.....		
BLOCK OUTLINE.....		
LOT LINES.....		
EASEMENT LINES.....		
STREET CENTER LINES.....		
RADIAL BEARING LINES.....		SHADE LINE TO 80%
MONUMENTS SET.....		
MONUMENTS SET IN CAST IRON BOX.....		
MONUMENTS FOUND.....		
MONUMENTS FOUND IN CAST IRON BOX.....		

STREET NAMES.....	NAME	LETTERS 0.175" HIGH NO. 2 RAPIDOGRAPH
LOT NUMBERS.....	36	LETTERS 0.175" HIGH NO. 2 RAPIDOGRAPH
BEARINGS, DISTANCES, CURVE DATA, COORDINATES, ETC. ....	N 56° E 50.00'	LETTERS 0.100" HIGH NO. 1 RAPIDOGRAPH
ADJACENT SUBDIVISIONS.....	AC HTS	LETTERS 0.175" HIGH NO. 0 RAPIDOGRAPH SHADOW LETTERING
ADJACENT LOT NUMBERS.....	124	LETTERS 0.175" HIGH NO. 0 RAPIDOGRAPH DOTTED LETTERING

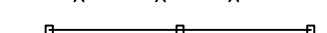
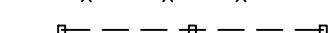
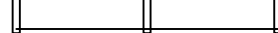
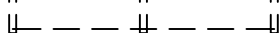
NO.	REVISED	BY	<b>Drafting Standards</b>	APPROVED  CITY ENGINEER RCE-28191
				DATE: 2-2-99
				STANDARD NO. <b>G-8</b>
DRAWN BY: MATT			<b>CITY OF RIPON</b>	
CHECKED BY: DJR				
V:\25_City of Ripon Standards\Standard Specifications\Drawings\General\g-8.dwg				

# DRAFTING STANDARDS (CONTINUED)

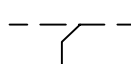
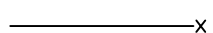
## 3. IMPROVEMENT PLANS

<u>DESCRIPTION</u>	<u>TO BE CONSTRUCTED</u>	<u>EXISTING</u>
SANITARY SEWER.....		
STORM DRAIN.....		
GAS LINE.....		
WATER LINE.....		
TELEPHONE.....		
CABLE TELEVISION.....		
GAS VALVE.....		
WATER VALVE.....		
ELECTRICAL CONDUIT.....		
MATCH LINE.....		
STA. 5+00		
MANHOLE.....		
CATCHBASIN.....		
GAS METER.....		
WATER METER.....		
CURB AND GUTTER.....		
SIDEWALK.....		
DRIVEWAY.....		
CONFORM PAVEMENT.....		
FIRE HYDRANT.....		
SIGN.....		
SANITARY SEWER CLEANOUT..		
UTILITY POLE.....		
GUARD RAIL.....		
BARRICADE.....		
FENCE.....		
RAILROAD.....		
WHEELCHAIR RAMP.....		
SANITARY SEWER SERVICE.....		
LAMPHOLE.....		

NO.	REVISED	BY	<b>Drafting Standards</b>	APPROVED	
				CITY ENGINEER	RCE-28191
DRAWN BY: MATT				DATE:	2-2-99
CHECKED BY: DJR			<b>CITY OF RIPON</b>	STANDARD NO.	<b>G-9</b>
V:\25_City of Ripon Standards\Standard Specifications\Drawings\General\g-9.dwg					

# DRAFTING STANDARDS (CONTINUED)

<u>DESCRIPTION</u>	<u>TO BE CONSTRUCTED</u>	<u>EXISTING</u>
ELECTRICAL CONDUIT.....	— T ——— T —	- - T - - - - T - -
PULL BOX.....		
PULL BOX WITH DETECTOR STUB IN CONDUIT.....		
STREET LIGHT.....		
COMBINATION TRAFFIC SIGNAL..... WITH BACKPLATE & LUMINAIRE		
COMBINATION TRAFFIC SIGNAL..... GREEN ARROW, AND BACKPLATE		
MASTARM SIGNAL WITH STREET..... NAME SIGN		
PROGRAMMED VISIBILITY HEAD..... WITH BACKPLATE		
PEDESTRIAN SIGNAL FACE.....		
PEDESTRIAN PUSH BUTTON AND... ASSOCIATED VEHICLE PHASE	PPB $\emptyset$ 6	PPB $\emptyset$ 6
INDUCTIVE DETECTOR LOOP.....		
TRAFFIC SIGNAL CONTROLLER..... CABINET WITH DOOR SWING AS SHOWN		
TYPE III OR III M SERVICE..... CABINET WITH DOOR SWING AS SHOWN		

NO.	REVISED	BY	<b>Drafting Standards</b>	APPROVED
				 CITY ENGINEER RCE-28191
DRAWN BY: MATT				DATE: 2-2-99
CHECKED BY: DJR				STANDARD NO. <b>G-10</b>
<b>CITY OF RIPON</b>				
V:\25_City of Ripon Standards\Standard Specifications\Drawings\General\g-10.dwg				

ON ALL SHEETS

NAME OF ENGINEERING FIRM	
NAME OF DEVELOPMENT	
TITLE OF SHEET	
_____ DESIGN ENGINEER	DATE: _____ RCE NO: _____ EXP DATE: _____

ON TITLE SHEET ONLY

CITY OF RIPON DEPARTMENT OF PUBLIC WORKS	
APPROVED: _____ MATTHEW J. MACHADO, P.E. CITY ENGINEER	DATE: _____ RCE NO: 58093 EXP DATE: _____
APPROVED SUBJECT TO THE DATA SHOWN. THE CITY OF RIPON AND THE UNDERSIGNED ARE NOT RESPONSIBLE FOR ERRORS AND OR OMISSIONS THAT MAY BE PRESENT ON THESE PLANS.	

TYPICAL TITLE AND APPROVAL  
BLOCK FOR IMPROVEMENT PLANS

APPROVED BY:	RIPON LIGHTING DISTRICT
_____	_____
SIGNATURE	DATE

APPROVED BY:	PUBLIC WORKS LANDSCAPE DEPARTMENT
_____	_____
SIGNATURE	DATE

APPROVED BY:	SOUTH SAN JOAQUIN IRRIGATION DISTRICT
_____	_____
SIGNATURE	DATE

SUPPLEMENTAL SIGNATURE BLOCKS (AS REQUIRED)  
(USE ON TITLE SHEET ONLY)

REVISIONS	NO.	DESCRIPTION	CITY APPROVAL	
			APPROVED BY	DATE

SEE NOTES ① & ②

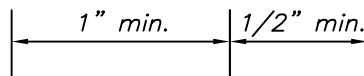

PLAN REVISION

- ① TO BE PLACED ADJACENT TO SIGNATURE BLOCK ON TITLE SHEET.
- ② TO BE PLACED ON ALL SHEETS WHICH INCLUDE THE REVISION.

NO.	REVISED	BY	<b>Signature Blocks</b>	APPROVED	_____ CITY ENGINEER RCE-58093
				DATE: 11-7-00	
				<b>CITY OF RIPON</b>	STANDARD NO. <b>G-11</b>
DRAWN BY: MATT					
CHECKED BY: DJR					
V:\25_City of Ripon Standards\Standard Specifications\Drawings\General\g-11.dwg					

***THIS PAGE  
INTENTIONALLY LEFT BLANK***

<i>NO.</i>	<i>REVISED</i>	<i>BY</i>		<i>APPROVED</i>
				<hr/>
				<i>CITY ENGINEER RCE-28191</i>
<i>DRAWN BY:</i>				<i>DATE:</i>
<i>CHECKED BY:</i>			<b><i>CITY OF RIPON</i></b>	<i>STANDARD NO. G-12</i>
V:\25_City of Ripon Standards\Standard Specifications\Drawings\General\g-12.dwg				



# Street Design Standards

## General

**Purpose and Intent** - The purpose and intent of these design standards is to clarify and consolidate present design criteria in the City of Ripon.

**Scope** - The design standards as hereinafter specified shall be used as the basis of design for all development within the jurisdiction of the City of Ripon.

**Design** - The design of each development is in itself a special case and these design standards shall not be construed to be the maximum required design on all or any separate phases of the construction. Under certain conditions, any or all of the phases of the development may be required to exceed these specifications. It is also recognized that there may be development where it is impossible to meet these design standards. It is suggested that these cases be reviewed with the City Engineer early in the design process to minimize reworking plans where deviation is not permitted.

**Final Authority** - The City Engineer shall be the final authority on all questions which may arise as to the interpretation of these standards. The City Engineer's decision shall be final and he shall have authority to enforce and make such decisions effective.

## Horizontal Alignment

**Conformity** - The arrangement, character, extent, width, grade, and location of all streets shall conform to the official map or general plan and shall be considered in their relation to existing and planned streets, to topographical conditions, to public convenience and safety and in their appropriate relation to the proposed uses of the land to be served by such streets. Where not shown on the official map or general plan, the arrangement and other design standards of streets shall conform to the provisions found herein.

**Relation to Adjoining Street System** - The arrangement of streets in new subdivisions shall make provisions for the continuation of the existing streets in adjoining areas.

**Projection of Streets** - Where adjoining areas are not subdivided, the arrangement of streets in new subdivisions shall make provisions for the proper projection of streets to the subdivision boundary line.

**Street Offsets Prohibited** - Centerline offsets of less than 260 feet shall be avoided unless approved by the City Engineer.

**Dead-End Streets or Cul-De-Sacs** - Dead-end streets or cul-de-sacs, destined to be so permanently shall not be longer than 300 feet and shall be provided at the closed end with a turn-around having a street property line diameter in conformity with the standard specifications.

NO.	REVISED	BY	<b>Street Design Standards</b>	APPROVED  CITY ENGINEER RCE-28191
				DATE: 2-2-99
DRAWN BY: Matt			<b>CITY OF RIPON</b>	STANDARD NO. <b>ST-1</b>
CHECKED BY: DJR				V:\25_City of Ripon Standards\Standard Specifications\Drawings\Streets\st-1.dwg

# Street Design Standards

(continued)

**Frontage Streets** - Where a subdivision abuts or contains an existing or proposed limited access street, the City Planning Commission may require frontage streets or other such treatment as may be necessary for adequate protection of residential properties and to afford separation of through and local traffic.

**Residential Streets** - Residential streets shall be designed so that their use by through traffic will be discouraged. (curvilinear)

**Street Widths** - Street right-of-way widths shall be established in accordance with the City of Ripon's Standard Specifications and Standard Details.

**Intersections** - The intersection of more than two streets at one point shall be avoided except where it is impractical to secure a reasonable street system otherwise. Streets shall intersect at an angle as near to a right angle as possible, and no intersections of streets at angles less than 75 degrees shall be approved. Street intersections shall be designed with a snipe in accordance with the City of Ripon's Standard Specifications and Standard Details.

**Curvature** - The minimum centerline radius of curvature shall be 750 feet on thoroughfares and arterials and 500 feet on collectors. Minimum centerline radius on other streets shall be 250 feet.

**Reverse Curves** - A tangent at least 100 feet long shall be introduced between reverse curves on streets if the radii of such curves are less than 1000 feet.

**Reserve Strips** - Reserve strips controlling access to streets shall be prohibited except under conditions approved by the Planning Commission.

**Street Grades** - All street grades shall conform to the requirement of the City Engineer. All elevations shall be based on U.S.G.S. datum.

**Half-Streets, and Part-Width Streets Prohibited** - Half-streets and part-width streets shall be prohibited unless approved by the City Engineer.

**Street Names and Numbers** - Names of new streets shall not duplicate existing or platted street names unless a new street is a continuation of, or in alignment with the existing or platted street house numbers shall be assigned in accordance with the house numbering system in effect. All street names and numbers shall be in compliance with City regulations.

**Access to Streets Across Ditches or Drainage Canals** - (1) The subdivider shall provide right-of-way and make provisions for improvements of all streets and structures that cross ditches or drainage canals lying within the subdivision or portion thereof. (2) Said ditches and canals shall be crossed in a manner approved by the City Engineer, South San Joaquin Irrigation District, and The Ripon Fire Department if necessary.

**Lane Widths** - Minimum lane width shall be 12 foot unless otherwise approved by City Engineer

NO.	REVISED	BY	<b>Street Design Standards</b>	APPROVED
				 CITY ENGINEER RCE-28191
DRAWN BY: Matt				DATE: 2-2-99
CHECKED BY: DJR			<b>CITY OF RIPON</b>	STANDARD NO. <b>ST-2</b>
V:\25_City of Ripon Standards\Standard Specifications\Drawings\Streets\st-2.dwg				

# Street Design Standards

(continued)

**Private Streets** - Private streets shall not be platted or mapped in a subdivision.

**Avoidance of Hardship to Adjoining Property Owners** - The street arrangements shall not be such as to cause hardship to owners of adjoining property in platting their own land and providing convenient access to it.

**Alleys** - Alleys shall not be permitted in residential areas, unless approved by the City Engineer. Alleys shall be provided in commercial and industrial districts, except that the City Planning Commission may waive this requirement where other definite and assured provisions are made for service access, such as off-street loading, unloading, and parking consistent with and adequate for the uses proposed.

The minimum right-of-way width of an alley shall be 25 feet. Dead-end alleys shall not be permitted.

## Vertical Alignment

**Top of Curb Grades** - Grades shall not be less than 0.33 percent and not greater than 6 percent. Where matching existing controls, the minimum grade may be reduced with the approval of the City Engineer.

The minimum top of curb elevation shall be 1 foot above the design water surface of the master plan storm drainage basin to which the proposed improvement is tributary. This minimum elevation may be obtained from the City Engineer.

A minimum top of curb elevation of 1 foot above the hydraulic grade line shall be maintained. The design parameter shall be a 25 year storm with a free outfall condition.

Grades on opposite sides of the street shall be the same wherever practical. The centerline grade of the pavement surface through an intersection shall not be more than 2 percent.

**Vertical Curves** - Where the algebraic difference in slope exceeds 1 percent, a vertical curve shall be used. The minimum length of vertical curve shall be  $1.2 AV$ , where "A" equals the algebraic difference in grades in percent / 100 and "V" is the design speed in miles per hour.

**Maximum Street Cut** - The maximum cut to top of curb from existing ground elevation shall be no greater than two (2) feet, unless approved by the City Engineer.

NO.	REVISED	BY	<b>Street Design Standards</b>	APPROVED  CITY ENGINEER RCE-28191
				DATE: 2-2-99
DRAWN BY: Matt			<b>CITY OF RIPON</b>	STANDARD NO. <b>ST-3</b>
CHECKED BY: DJR				
V:\25_City of Ripon Standards\Standard Specifications\Drawings\Streets\st-3.dwg				

# Conditions for All Weather Roads

Prior to issuing a building permit, the City of Ripon Building Inspection Department shall receive written confirmation from the City Engineer and Ripon Fire Chief stating that all streets within the development meet "All Weather Road" standards:

To be considered an "All Weather Road" the following criteria shall be met:

1. A soil report, prepared by a soils engineer, shall be submitted to the City Engineer. The report shall include the following information: a) soil classification by Unified Soil Classification System; b) R-Values; c) density curves showing maximum dry density and optimum moisture content; d) Log of soil borings; e) an evaluation, by the soils engineer, stating minimum requirements for the native soil to function as an "All Weather Road".
2. All curb, gutter, and sidewalk shall be installed in accordance with project plans and specifications.
3. All trenches in the road area shall be filled and compacted to City of Ripon's Standard Specifications and Standard Details. Trenching in an approved "All Weather Road" surface without written authorization from the City Engineer shall be cause for issuance of a stop work notice by the Building Inspection Department.
4. Fire hydrants and water systems shall be pressure tested, bacteriological tested and approved. Blank plates and jumpers shall be removed to provide an approved water supply capable of supplying required fire flow for fire protection to all premises upon which buildings or portions of buildings are hereafter constructed, in accordance with the current "Uniform Fire Code".
5. Sewer and storm drain system shall be installed, tested, and approved.
6. Street lights shall be installed and functional.
7. All utilities shall have a minimum of thirty inches (30") of cover.
8. Prior to acceptance of subdivision roads as "All Weather Roads" they shall be inspected and approved by the City of Ripon.

The City Engineer or Ripon Fire Chief shall have the authority to terminate construction at any time if any of the aforementioned conditions are violated.

NO.	REVISED	BY	<b>All Weather Roads</b>	APPROVED
				 CITY ENGINEER RCE-28191
				DATE: 2-2-99
				STANDARD NO. <b>ST-4</b>
DRAWN BY: Matt			<b>CITY OF RIPON</b>	
CHECKED BY: DJR				
V:\25_City of Ripon Standards\Standard Specifications\Drawings\Streets\st-4.dwg				

## TRIP GENERATION FACTORS

THE FOLLOWING TRIP END FACTORS SHALL BE USED IN DETERMINING  
THE AVERAGE DAILY TRAFFIC INVOLVED IN STREET DESIGN.

TRIP END: THE ORIGIN OR DESTINATION OF A TRIP. EACH TRIP HAS TWO ENDS.  
G.S.F.:GROSS SQUARE FEET OF FLOOR AREA.

	<u>AVERAGE WEEKDAY VEHICLE TRIP ENDS(TE)</u>
SINGLE FAMILY _____	10 TE/DWELLING UNIT
APARTMENTS _____	6.1 TE/DWELLING UNIT
CONDOMINIUM/PUD _____	8.6 TE/DWELLING UNIT
MOBILE HOME _____	5.4 TE/DWELLING UNIT
RETIREMENT COMMUNITY _____	3.3 TE/DWELLING UNIT
HOTELS _____	11.0 TE/ROOM
MOTELS _____	9.6 TE/ROOM
CITY PARK _____	60 TE/ACRE, 7.8 TE/PARK. SPACE
GENERAL OFFICE _____	17.7 TE/1000 G.S.F.
MEDICAL OFFICE _____	75 TE/1000 G.S.F.
FAST FOOD/DRIVE THRU _____	680 TE/1000 G.S.F.
FREE STANDING RETAIL _____	73.7 TE/1000 G.S.F.
SERVICE STATION _____	133 TE/PUMP OR 748 TE
SUPERMARKET _____	126 TE/1000 G.S.F.
CONVENIENCE MARKET W/GAS PUMPS _____	730 TE/1000 G.S.F.
CONVENIENCE MARKET _____	473 TE/1000 G.S.F.
INDUSTRIAL/INDUSTRIAL PARK _____	7.6 TE/1000 G.S.F.
INDUSTRIAL SERVICE _____	20.26 TE/1000 G.S.F.
DAY CARE/PRESCHOOL _____	79.0 TE/1000 G.S.F.
OFFICE PARK _____	20.7 TE/1000 G.S.F.
SHOPPING CENTER _____	SEE(ITE)TRIP GENERATION REPORT

FOR LAND USES AND/OR DEVELOPMENTS NOT SHOWN ABOVE, CONTACT THE CITY TRAFFIC ENGINEER.

SOURCE: "TRIP GENERATION" AN INFORMATIONAL REPORT, INSTITUTE OF TRANSPORTATION ENGINEERS, 6th EDITION AND OTHER TRIP GENERATION PUBLICATIONS.

NO.	REVISED	BY	<b>Trip Generation Factors</b>	APPROVED	
					CITY ENGINEER RCE-28191
				DATE: 2-2-99	
DRAWN BY: MATT			<b>CITY OF RIPON</b>	STANDARD NO. <b>ST-5</b>	
CHECKED BY: DJR					
V:\25_City of Ripon Standards\Standard Specifications\Drawings\Streets\st-5.dwg					

## RESISTANCE VALUE OF BASEMENT SOIL (R-VALUE)

REQUIRED THICKNESS OF GRAVEL FOR  
MINIMUM TENSILE STRENGTH MATERIALS

(GRAVEL EQUIVALENT IN FEET)

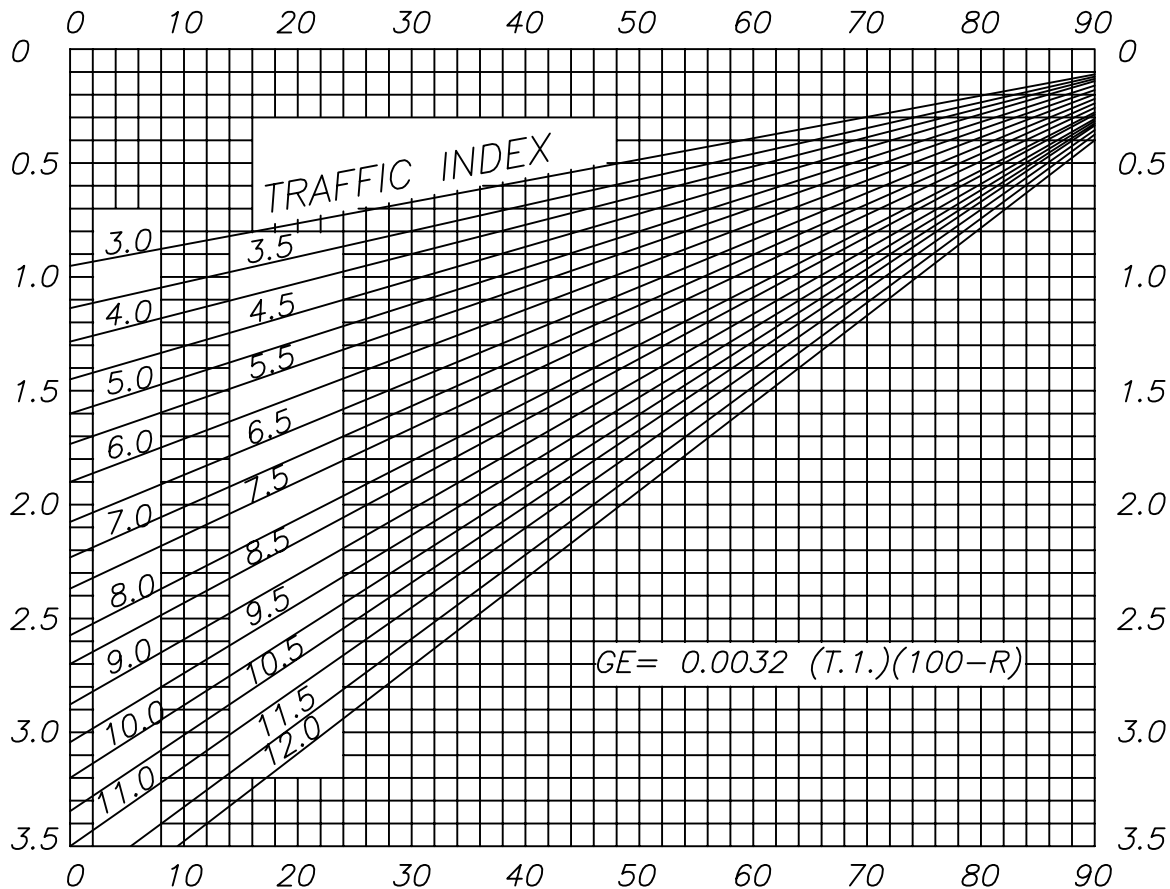

### PROCEDURE FOR USE OF CHARTS

FIND TOTAL GRAVEL EQUIVALENT BY INTER-  
SECTING TRAFFIC INDEX (DETERMINED) WITH  
EXISTING BASEMENT SOIL R-VALUE AND READ  
THE THICKNESS IN FEET.

REFER TO THE CHART AT RIGHT FOR  
GRAVEL EQUIVALENT FACTORS OF  
SURFACE AND BASE MATERIALS.

- A. USE 3-1/8" (80MM) THICKNESS  
FOR CONCRETE PAVERS
- B. USE 0.21' MINIMUM THICKNESS  
FOR A.C.

\* A.C. MAY BE USED WITH SPECIAL  
APPROVAL FROM CITY ENGINEER

#### GRAVEL EQUIVALENT FACTORS

T.I.	PAVERS	A.C.*	A.B.	A.S.B.	L.T.S.B.
0-5.0	2.00	2.50	1.1	1.0	1.2
5.5-6.0	2.00	2.32	—	—	—
6.5-7.0	2.00	2.14	—	—	—
7.5-8.0	2.00	2.01	—	—	—
8.5-9.0	2.00	1.89	—	—	—
9.5-10.0	2.00	1.79	—	—	—
10.5-11.0	2.00	1.71	—	—	—
11.5-12.0	2.00	1.64	1.1	1.0	1.2

NO.	REVISED	BY
DRAWN BY: MATT		
CHECKED BY: DJR		
V:\25_City of Ripon Standards\Standard Specifications\Drawings\Streets\st-6.dwg		

**STRUCTURAL CONCRETE  
PAVERS AND PAVEMENT  
DESIGN CHART**

**CITY OF RIPON**

APPROVED

*[Signature]*  
CITY ENGINEER RCE-28191

DATE: 2-2-99

STANDARD NO. **ST-6**

## STREET SECTION CHART

R/W	STREET NAME	CURB	WALK	ACTUAL STREET WIDTH	MEDIAN	TRAFFIC INDEX	SOIL R - VALUE	A.B. SECTION	TOTAL SECTION

<u>STREET TYPE</u>	<u>(T.I.)</u>
MAJOR	10
COLLECTOR	8
INDUSTRIAL	9
RESIDENTIAL	6
CUL-DE-SAC	4.5

**DESIGN NOTES:**

1. CONCRETE PAVERS STRUCTURAL DESIGN SHALL BE BASED UPON CITY OF RIPON STANDARD ST-6.
2. CONSTRUCTION SHALL CONFORM WITH THE LATEST STANDARD SPECIFICATION OF THE STATE OF CALIFORNIA.  
- AGGREGATE BASE SHALL BE CLASS "2", COMPACTED TO 98% RELATIVE COMPACTION.
3. BASE SHALL BE WATERED AND COMPACTED PURSUANT TO STATE SPECIFICATIONS EXCEPT - 95% TO 18" BELOW FINISHED SUBGRADE.
4. MAXIMUM SOIL R-VALUE TO BE USED FOR DESIGN IS 50.
5. VERTICAL FACE OF CURB, GUTTER, AND SIDEWALK SHALL BE USED IN ALL STREET DESIGNS, EXCEPT FOR CUL-DE-SAC STREET DESIGNS, WHERE DRIVE OVER CURB IS SUBSTITUTED FOR VERTICAL FACE CURB.
6. ALL TRENCHES IN STREETS SHALL BE FULLY COMPACTED, PER CITY OF RIPON STANDARDS U-6 AND U-7 BEFORE PLACING ANY CONCRETE PAVERS.
7. VERTICAL CURVE IS REQUIRED WHEN TOTAL SLOPE DIFFERENTIAL OF GUTTER GRADE IS 1% OR MORE:

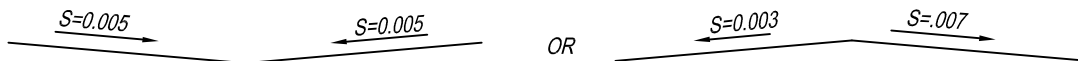

8. CONCRETE PAVERS SHALL CONFORM TO CITY OF RIPON STANDARD ST-8A, AND BE INSTALLED PER MANUFACTURERS RECOMMENDATIONS. A.B. SECTION SHALL CONFORM WITH CITY OF RIPON STANDARD ST-6 FOR CONCRETE PAVERS
9. COMPACTION TESTS SHALL BE PERFORMED ON SUB-GRADE PRIOR TO ROCK PLACEMENT AND ON SUB-BASE PRIOR TO SAND PLACEMENT FOR CONCRETE PAVERS. COMPACTION TESTS SHALL BE TAKEN AT THE DISCRETION OF THE CITY'S PUBLIC WORKS INSPECTOR. ALL TEST RESULTS OF THE COMPACTION TESTS SHALL BE REPORTED TO THE CITY BY THE SOILS TESTING AGENCY THROUGH INSPECTION REPORTS PRIOR TO PLACING ANY CONCRETE PAVERS.
10. PROFILE DRAWINGS SHALL INCLUDE FINISH CENTERLINE ELEVATION GRADE LINES ON NEW CONSTRUCTION.
11. THE MINIMUM GUTTER SLOPE SHALL BE 0.0033.
12. EXTENSION OF 4" THICK SIDEWALK UP TO THE PROPERTY LINE MAY BE REQUIRED FOR CERTAIN TYPES OF DEVELOPMENTS (COMMERCIAL, ETC. - TO ACCOMODATE FOR TREE WELLS, ETC.).
13. ALL STRIPING TO BE ACCOMPLISHED BY USING COLORED CONCRETE PAVERS OR AS APPROVED BY CITY ENGINEER.

NO.	REVISED	BY	<b>STREET SECTION CHART AND STREET DESIGN STANDARDS</b>	APPROVED  CITY ENGINEER RCE-28191
				DATE: 2-2-99
				STANDARD NO. <b>ST-7</b>
DRAWN BY: MCP			<b>CITY OF RIPON</b>	
CHECKED BY: DJR				
V:\125_City of Ripon Standards\Standard Specifications\Drawings\Streets\st-7.dwg				

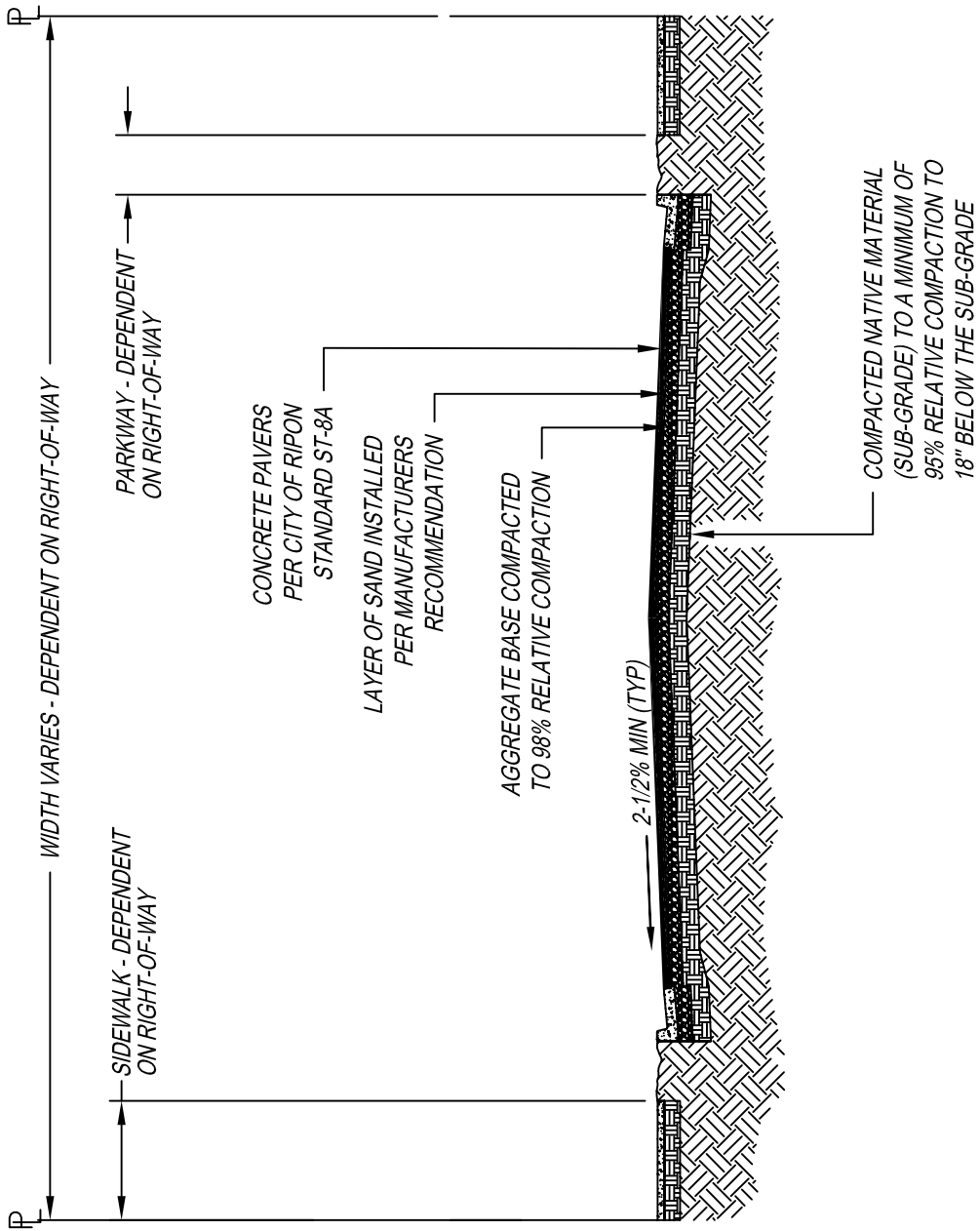

**NOTES:**  
 1. ALL CURB, GUTTER, AND SIDEWALK ARE TO BE INSTALLED PER CITY OF RIPON STANDARDS.

NO.	REVISED	BY
	1-2003	MJM
DRAWN BY: MCP		
CHECKED BY: DJR		
V:\125_City of Ripon Standards\Standard Specifications\Drawings\Streets\st-8.dwg		

**STREET DESIGN STANDARDS**

**CITY OF RIPON**

APPROVED

*[Signature]*

CITY ENGINEER RCE-28191

DATE: 2-2-99

STANDARD NO. **ST-8**



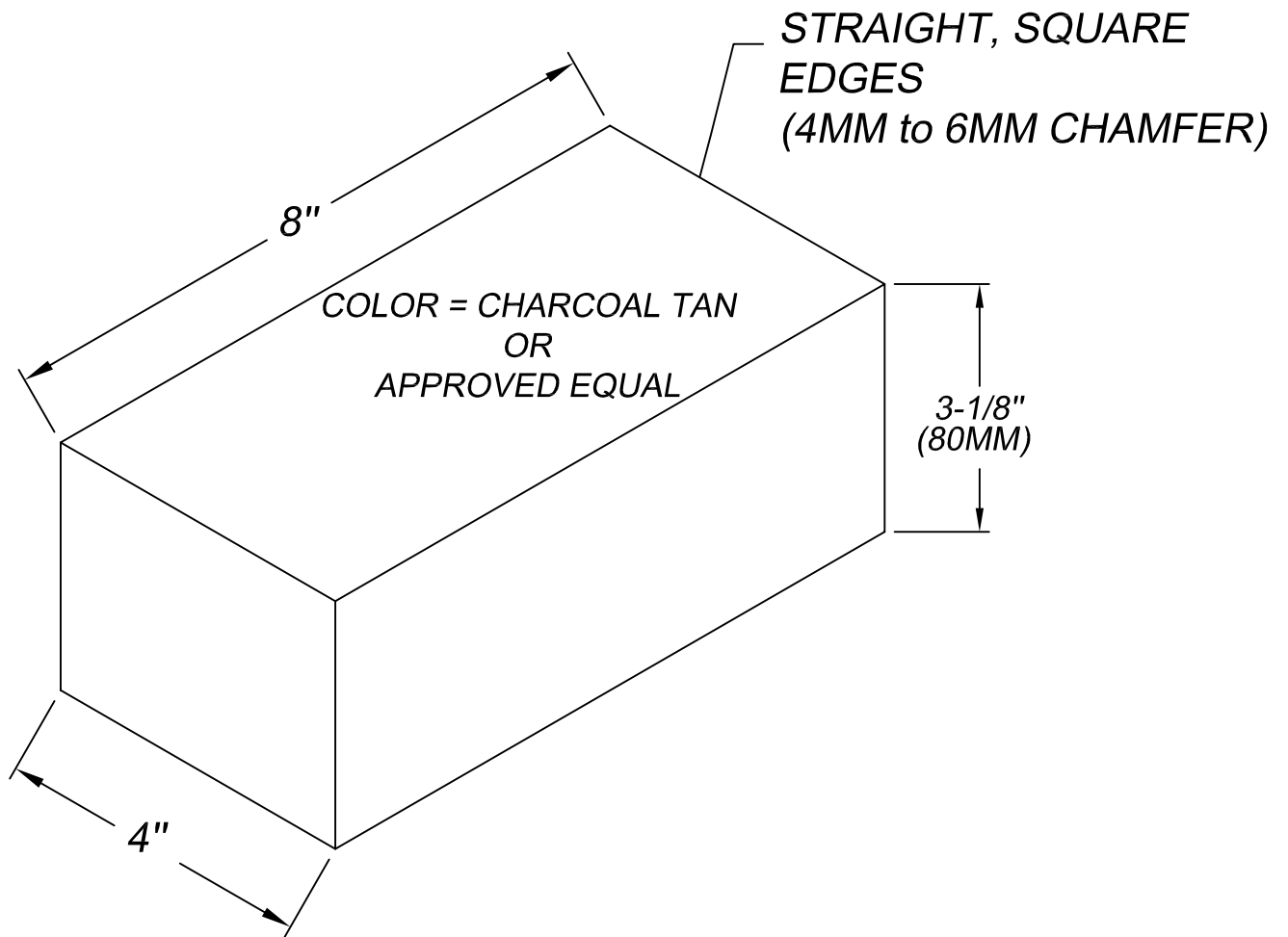

**CONCRETE PAVER SPECIFICATIONS**

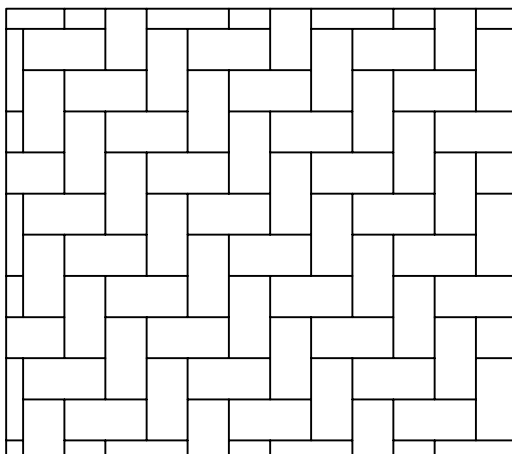

CONCRETE PAVERS SHALL  
BE INSTALLED USING A  
HERRINGBONE PATTERN

NO.	REVISED	BY	<b>CONCRETE PAVER STANDARDS</b>	APPROVED
				 CITY ENGINEER RCE-28191
				DATE: 2-2-99
DRAWN BY: MCP			<b>CITY OF RIPON</b>	STANDARD NO. <b>ST-8A</b>
CHECKED BY: DJR				
V:\125_City of Ripon Standards\Standard Specifications\Drawings\Streets\st-8a.dwg				

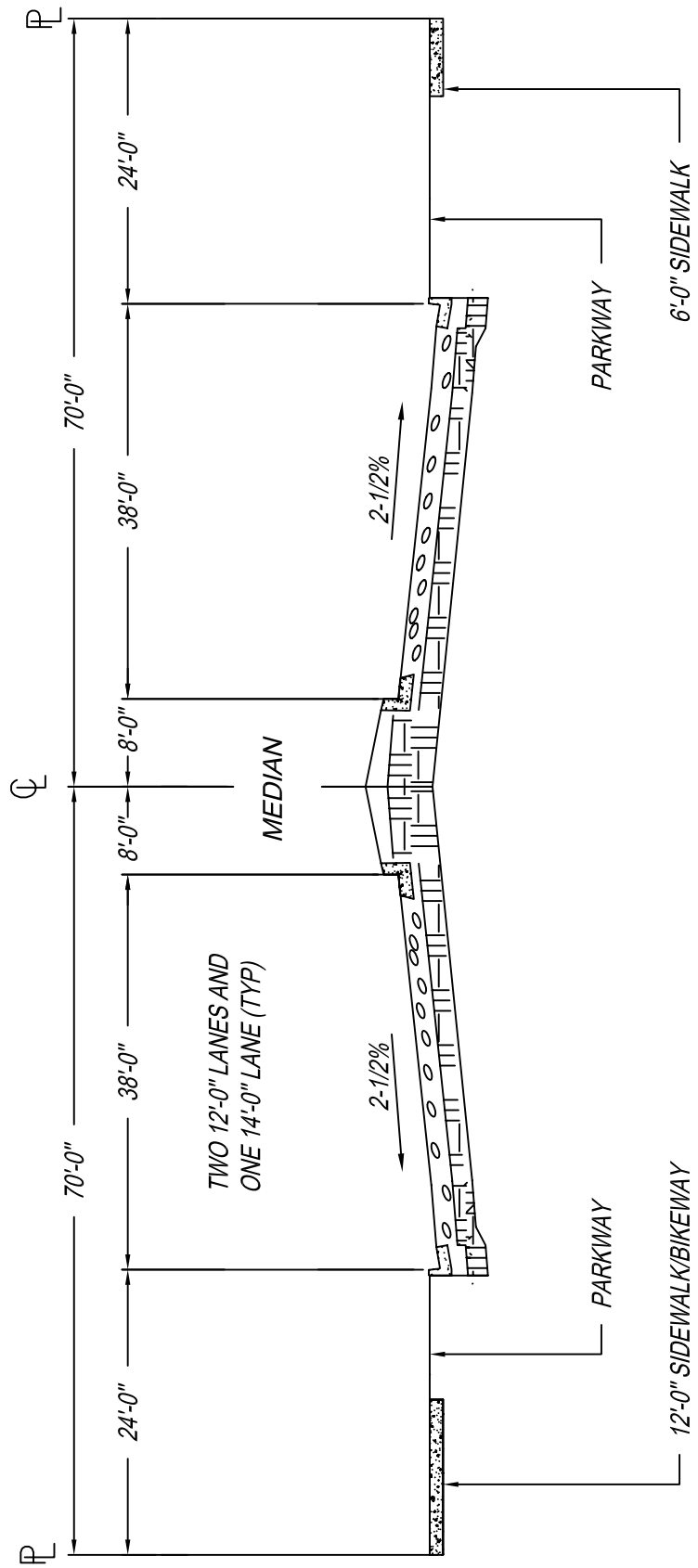

**DESIGN PARAMETERS:**

1. DESIGN SPEED IS 40 MPH.
2. MINIMUM CENTER LINE RADIUS IS 1,200 FEET.
3. TRAFFIC INDEX IS 10
4. 10' P.U.E. TYPICAL BEHIND PROPERTY LINE.

NO.	REVISED	BY
DRAWN BY: MCP		
CHECKED BY: DJR		
V: 125_City of Ripon Standards \ Standard Specifications \ Drawings \ Streets \ st-9.dwg		

**140' Major Arterial Street Section**

**CITY OF RIPON**

APPROVED

*W. Dale J. ...*

CITY ENGINEER RCE-28191

DATE: 2-2-99

STANDARD NO. **ST-9**

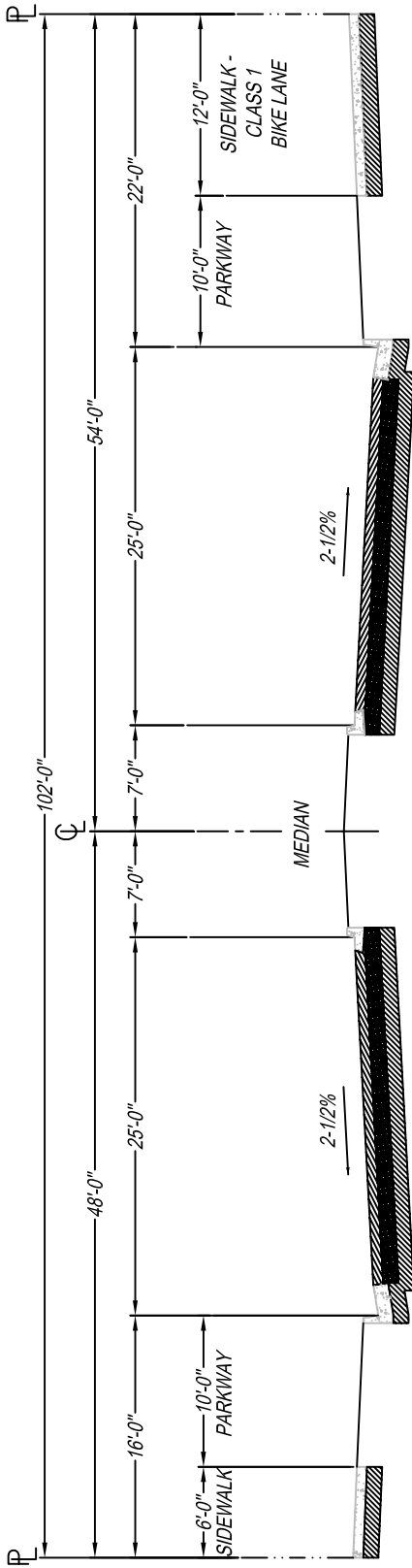

102' RIGHT-OF-WAY  
MINOR ARTERIAL

\* 10' P.U.E. TYPICAL  
BEHIND PROPERTY LINE

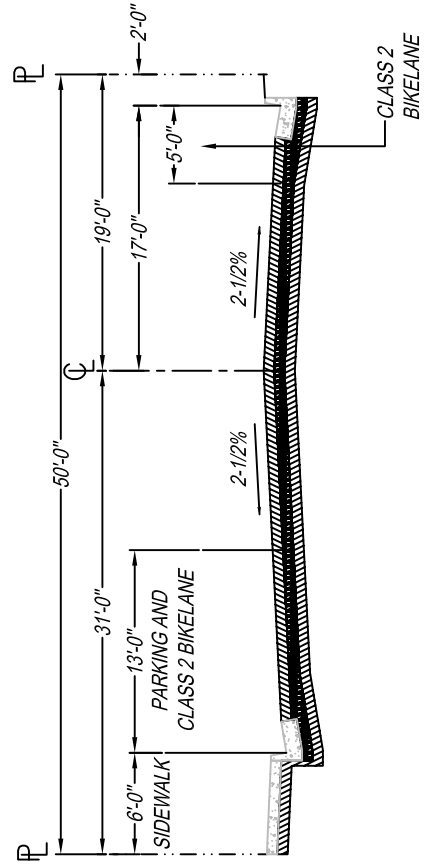

50' RIGHT-OF-WAY  
FRONTAGE ROAD

\* 10' P.U.E. TYPICAL  
BEHIND PROPERTY LINE

NO.	REVISED	BY
DRAWN BY: MCP		
CHECKED BY: DJR		
V: 125 City of Ripon Standards   Standard Specifications   Drawings   Streets   st-10.dwg		

102' and 50'  
Street Sections

CITY OF RIPON

APPROVED

*[Signature]*  
CITY ENGINEER RCE-28191

DATE: 2-2-99

STANDARD NO. ST-10

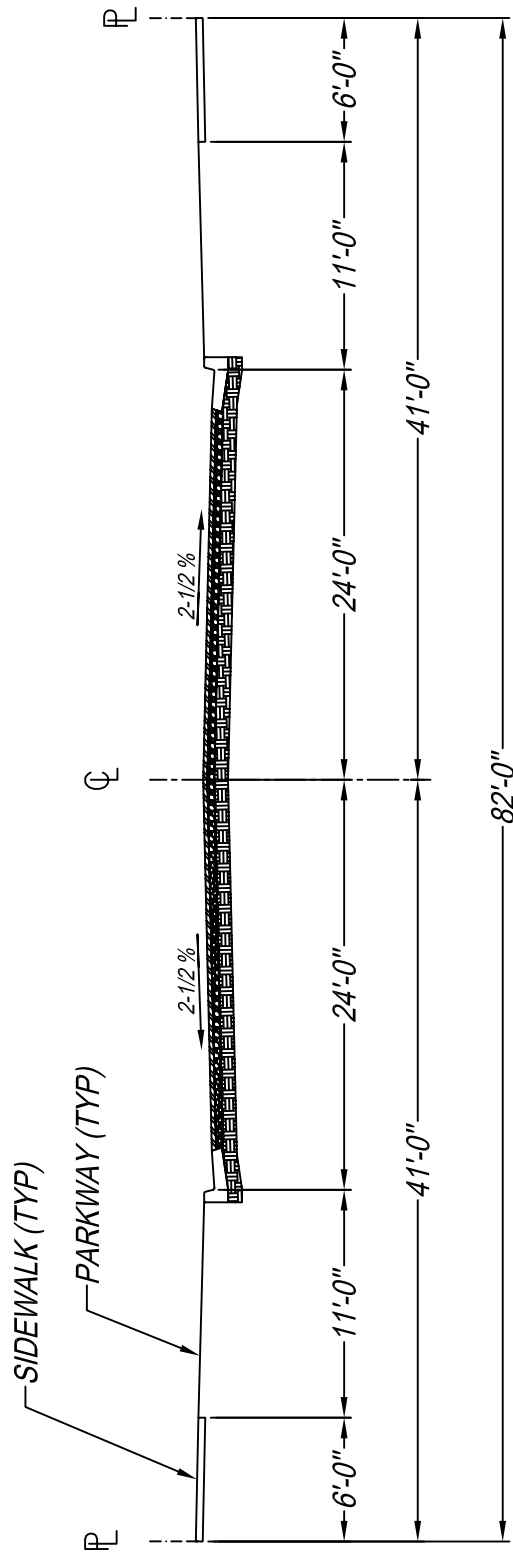

**82' RIGHT-OF-WAY  
COMMERCIAL OR  
RESIDENTIAL COLLECTOR**

**\* 10' P.U.E. TYPICAL  
BEHIND PROPERTY LINE**

NO.	REVISED	BY
DRAWN BY: MCP		
CHECKED BY: DJR		
V: 125_City of Ripon Standards   Standard Specifications   Drawings   Streets   st-10a.dwg		

**82'**  
**Street Section**

**CITY OF RIPON**

APPROVED  
  
 CITY ENGINEER RCE-28191  
 DATE: 2-2-99  
 STANDARD NO. **ST-10a**

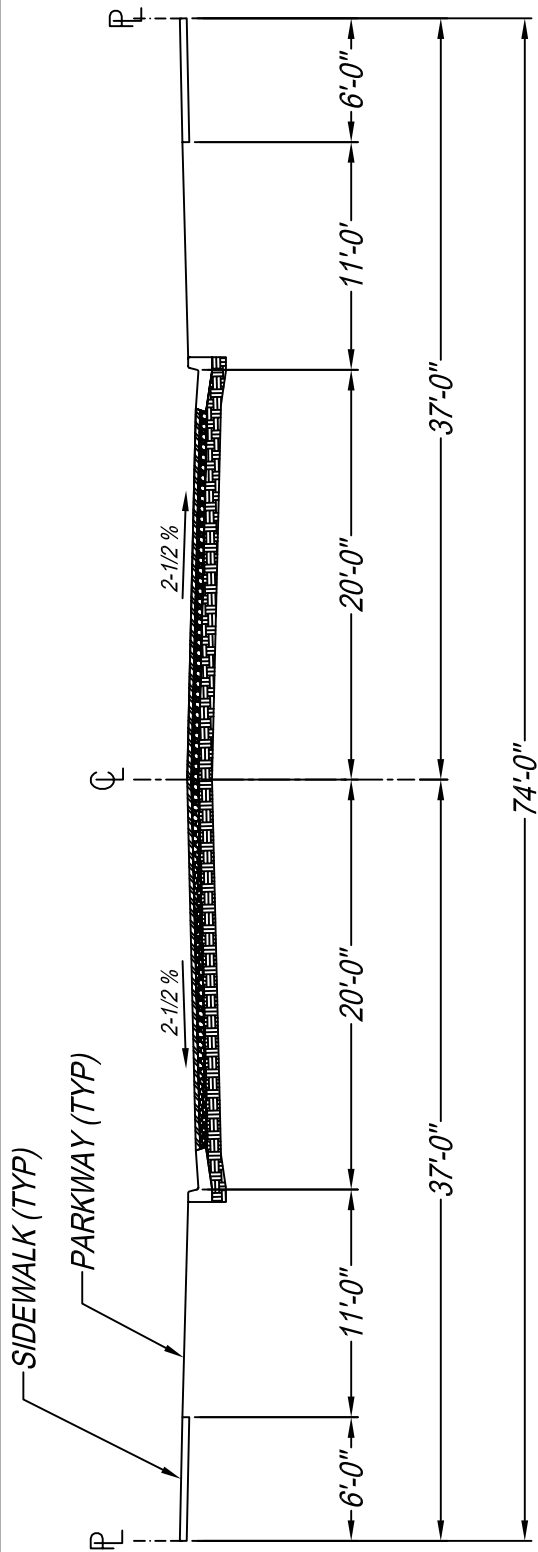

74' RIGHT-OF-WAY  
RESIDENTIAL STREET

\* 10' P.U.E. TYPICAL  
BEHIND PROPERTY LINE

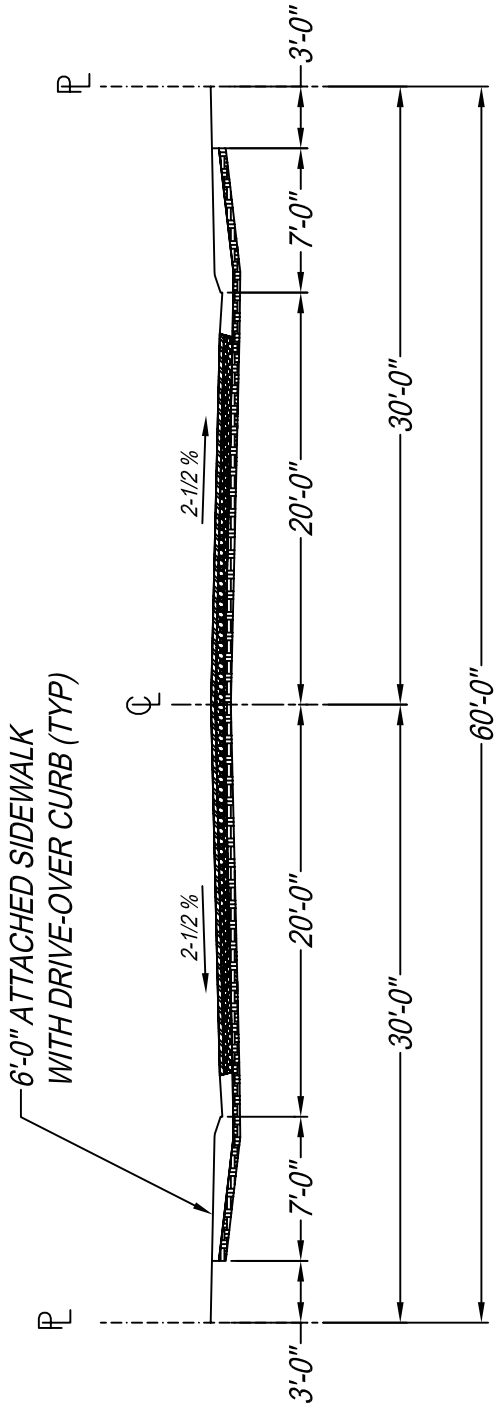

60' RIGHT-OF-WAY  
STANDARD CUL-DE-SAC

\* 10' P.U.E. TYPICAL  
BEHIND PROPERTY LINE

NO.	REVISED	BY
DRAWN BY: MCP		
CHECKED BY: DJR		
V:\25_City of Ripon Standards\Standard Specifications\Drawings\Streets\st-11.dwg		

74' and 60'  
Street Sections

CITY OF RIPON

APPROVED

*David J. ...*  
CITY ENGINEER RCE-28191

DATE: 2-2-99

STANDARD NO. **ST-11**

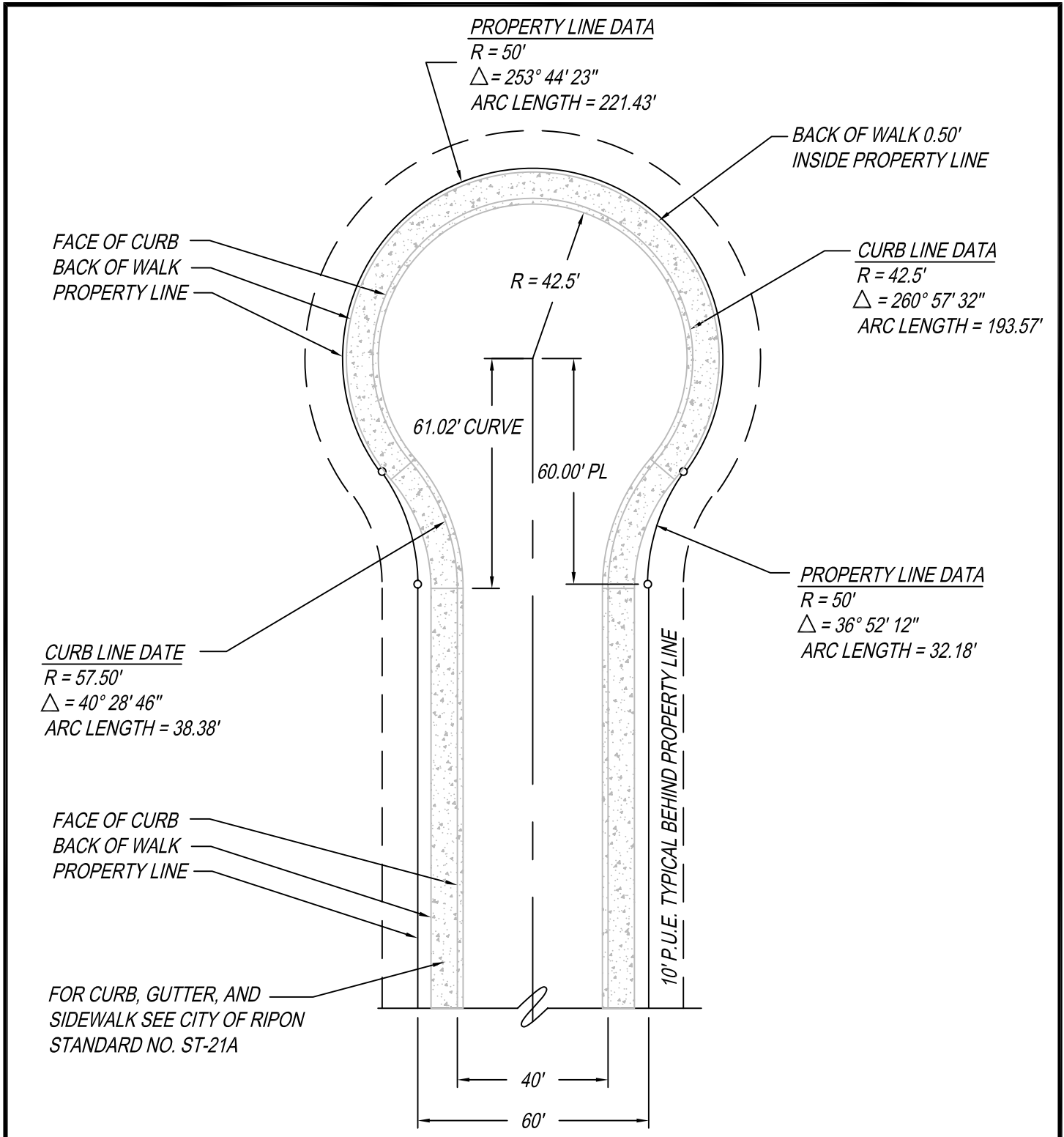

**NOTES:**

1. THIS IS NOT A TYPICAL CUL-DE-SAC, MAY BE USED WITH APPROVAL OF CITY ENGINEER ONLY.
2. EXPANSION JOINT IS REQUIRED AT ALL POINTS OF TRANSITION.

NO.	REVISED	BY	<b>Alternate Cul-De-Sac Detail</b>	APPROVED  CITY ENGINEER RCE-28191
				DATE: 2-2-99
DRAWN BY: MCP				<b>CITY OF RIPON</b>
CHECKED BY: DJR				
V: 1.25_City of Ripon Standards   Standard Specifications   Drawings   Streets   st-12.dwg				

PROPERTY LINE DATA

R = 55'  
 $\Delta = 180^\circ$   
 ARC LENGTH = 172.79'

10' P.U.E. (TYP)  
 PROPERTY LINE

REFER TO CUL-DE-SAC  
 ISLAND DETAIL ST-13B

R 10' (TYP)

R 45'

SIDEWALK 3'  
 INSIDE PL

40'

10' (TYP)

PROPERTY LINE DATA

R = 55'  
 $\Delta = 42^\circ 24' 35''$   
 ARC LENGTH = 39.75'

PROPERTY LINE DATA

R = 45'  
 $\Delta = 42^\circ 24' 35''$   
 ARC LENGTH = 32.52

FOR CURB, GUTTER, AND  
 SIDEWALK SEE CITY OF  
 RIPON STANDARD NO. ST-21A

260' MAX

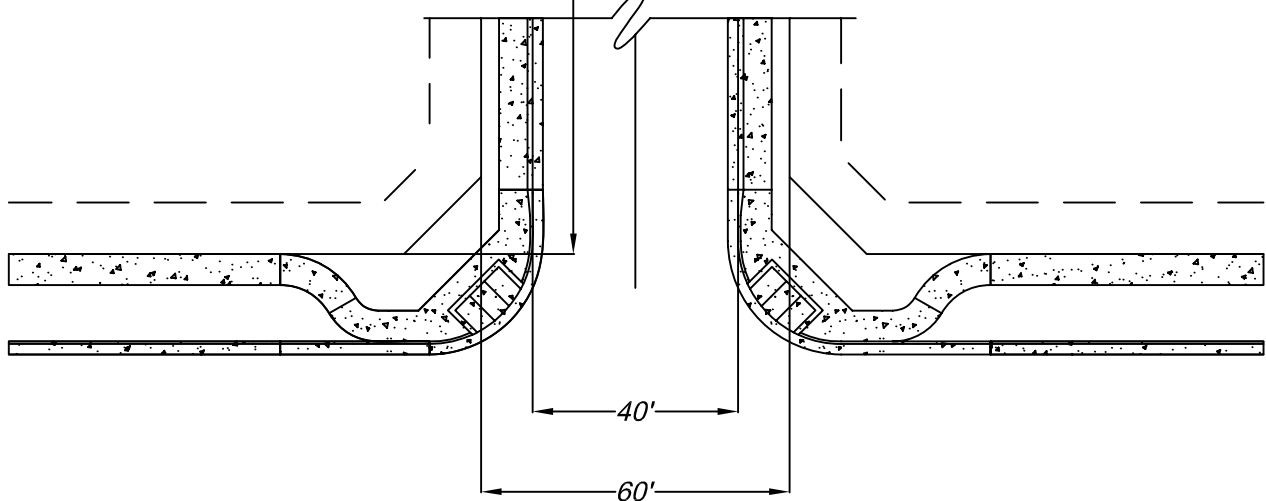

NO.	REVISED	BY
DRAWN BY: MCP		
CHECKED BY: DJR		
V:\125_City of Ripon Standards\Standard Specifications\Drawings\Streets\st-13.dwg		

**Standard  
 Cul-De-Sac Detail**

**CITY OF RIPON**

APPROVED
CITY ENGINEER RCE-28191
DATE: 2-2-99
STANDARD NO. <b>ST-13</b>

PROPERTY LINE DATA

$R = 52'$   
 $\Delta = 180^\circ$   
 ARC LENGTH = 163.36'

10' P.U.E. (TYP)  
 PROPERTY LINE

REFER TO CUL-DE-SAC  
 ISLAND DETAIL ST-13B

R 10' (TYP)

R 45'

240' MAX

10' (TYP)

PROPERTY LINE DATA

$R = 52'$   
 $\Delta = 40^\circ 48' 24''$   
 ARC LENGTH = 36.68'

PROPERTY LINE DATA

$R = 45'$   
 $\Delta = 41^\circ 24' 35''$   
 ARC LENGTH = 35.05'

FOR CURB, GUTTER, AND  
 SIDEWALK SEE CITY OF  
 RIPON STANDARD NO. ST-21A

260' MAX

48'

62'

NO.	REVISED	BY
DRAWN BY: MCP		
CHECKED BY: DJR		
V:\25_City of Ripon Standards\Standard Specifications\Drawings\Streets\st-13a.dwg		

**Extended Standard  
 Cul-De-Sac Detail**

**CITY OF RIPON**

APPROVED

*[Signature]*  
 CITY ENGINEER RCE-28191

DATE: 2-2-99

STANDARD NO. **ST-13a**



# SECTION A-A

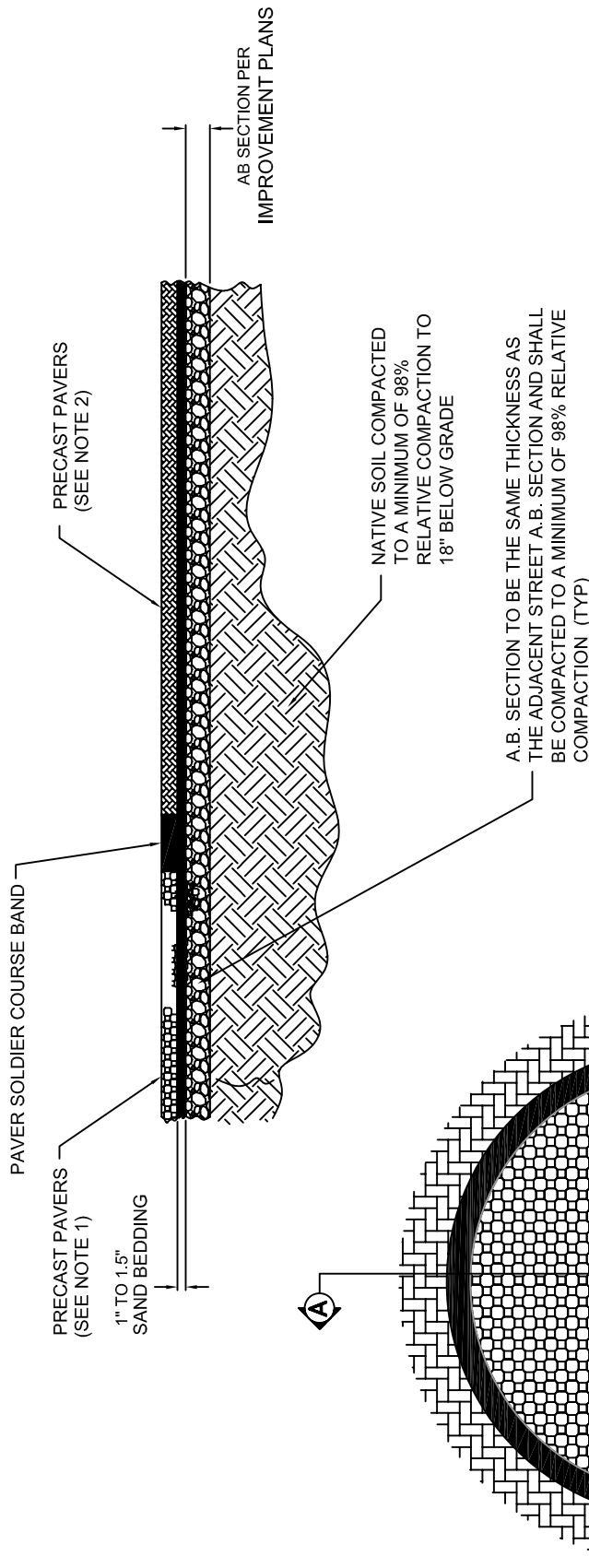

## NOTES:

1. BRICK PAVERS TO BE INSTALLED PER MANUFACTURERS RECOMMENDATION:  
 SIZE: 80mm, 5.5" INTERLOCKING PAVERS  
 STYLE: SPECTRUM  
 COLOR: MENDOCINO
2. BRICK PAVERS TO BE INSTALLED PER MANUFACTURERS RECOMMENDATION:  
 SIZE: 80mm, 3.15" INTERLOCKING PAVERS  
 STYLE: 90 DEGREE HERRINGBONE  
 COLOR: CHARCOAL TAN

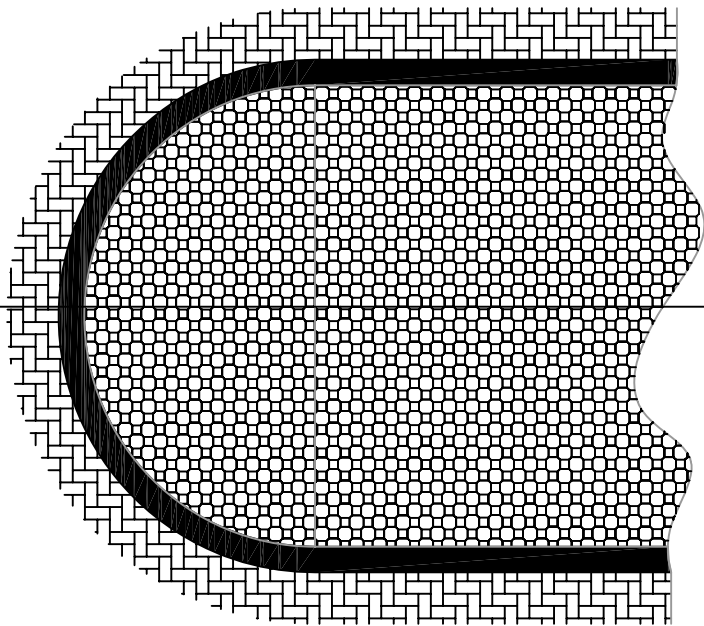

NO.	REVISED	BY
DRAWN BY: TP		
CHECKED BY: DJR		
V:\125_City of Ripon Standards\Standard Specifications\Drawings\Streets\st-13b.dwg		

**Cul-De-Sac  
Island Detail**

CITY OF RIPON

APPROVED

*[Signature]*

CITY ENGINEER RCE-2819T

DATE: 2-2-99

STANDARD NO. **ST-13b**

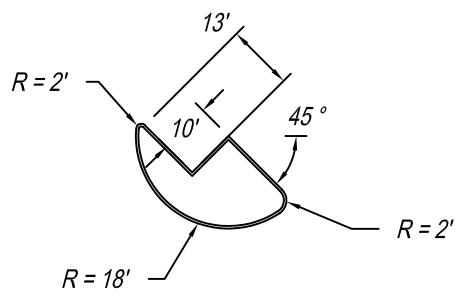
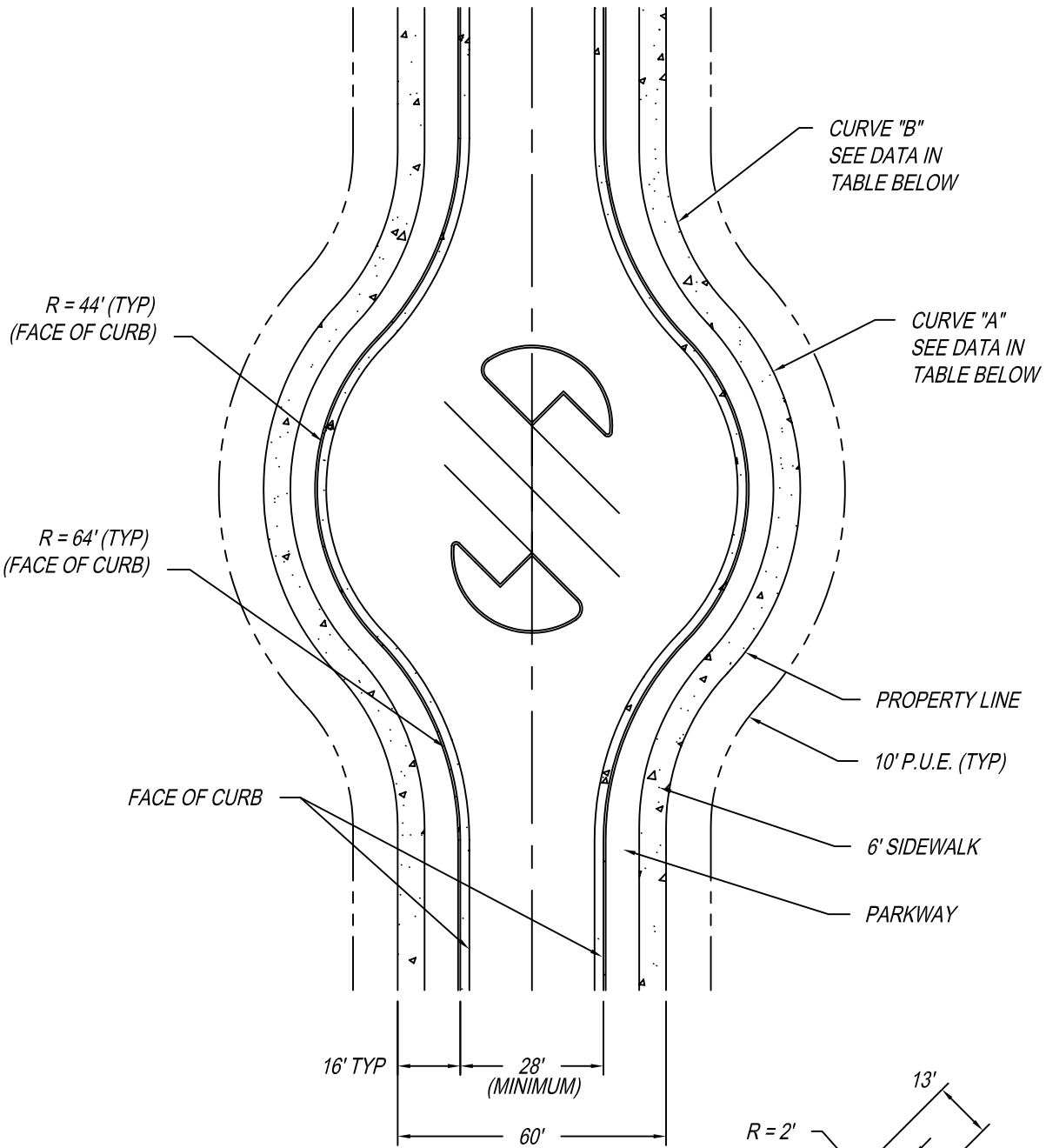

**ISLAND DETAIL**

R/W		CURVE A	CURVE B
60	R	60.00'	50.00'
	△	-----°-----	-----°-----
	ARC. L	-----	-----

\* PRIOR APPROVAL OR DIRECTION REQUIRED FROM THE CITY ENGINEER FOR USE OF THIS STANDARD.

NO.	REVISED	BY	<b>Special Residential Parking</b>	APPROVED
				 CITY ENGINEER RCE-28191
				DATE: 2-2-99
DRAWN BY: TP			<b>CITY OF RIPON</b>	STANDARD NO. <b>ST-14</b>
CHECKED BY: DJR				
<small>V: 125 City of Ripon Standards   Standard Specifications   Drawings   Streets   st-14.dwg</small>				

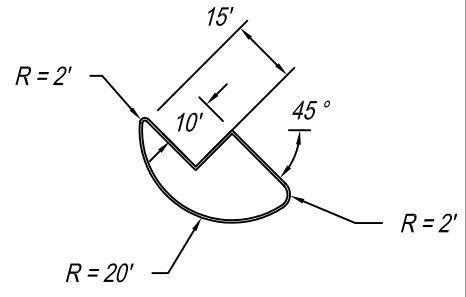
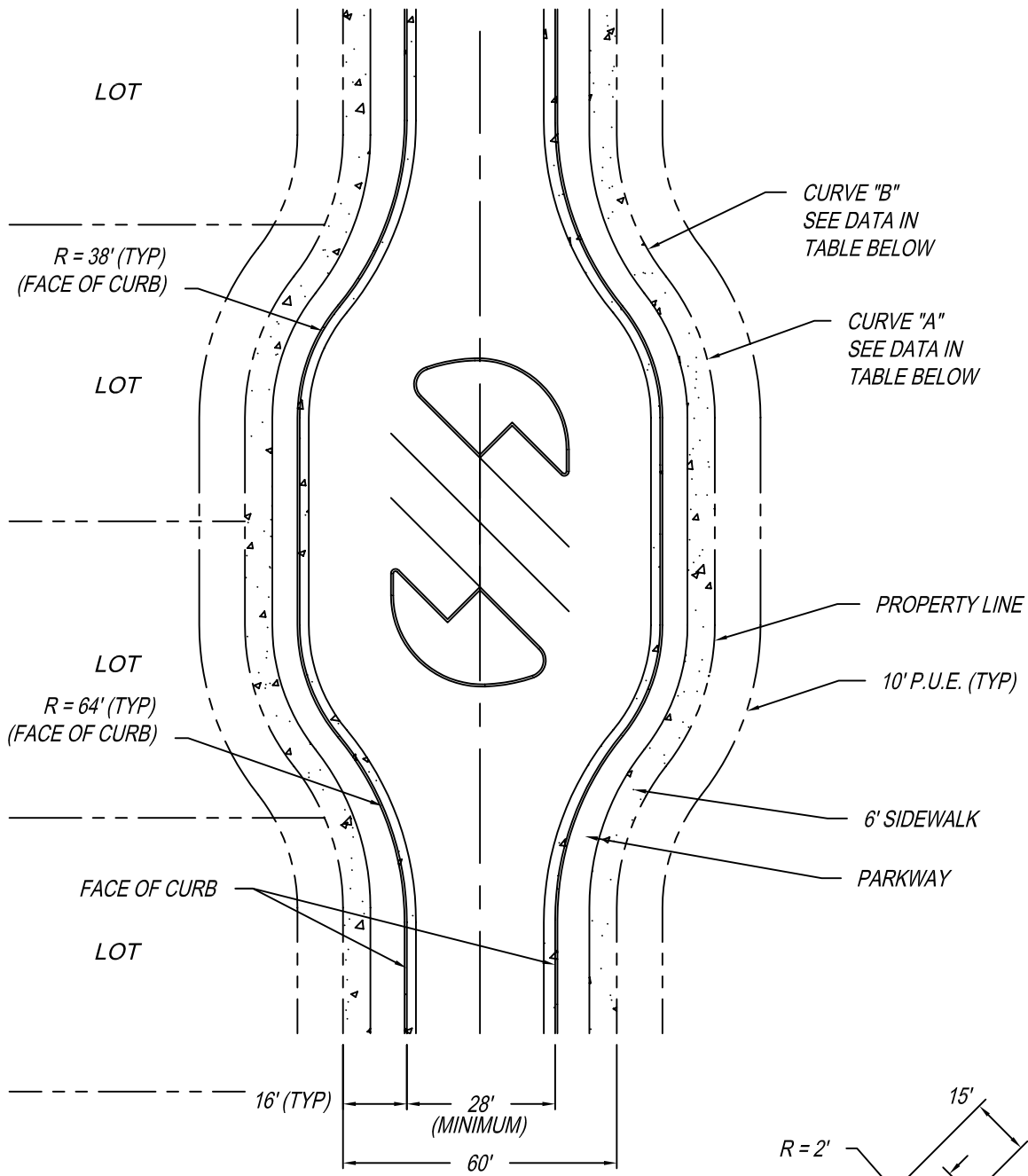

**ISLAND DETAIL**

R/W		CURVE A	CURVE B
60	R	60.00'	50.00'
	△	-----°-----	-----°-----
	ARC. L	-----	-----

\* PRIOR APPROVAL OR DIRECTION REQUIRED FROM THE CITY ENGINEER FOR USE OF THIS STANDARD.

NO.	REVISED	BY	<b>Special Residential Parking</b>	APPROVED
				 CITY ENGINEER RCE-28191
				DATE: 2-2-99
DRAWN BY: TP			<b>CITY OF RIPON</b>	STANDARD NO. <b>ST-15</b>
CHECKED BY: DJR				
<small>V: 1.25_City of Ripon Standards   Standard Specifications   Drawings   Streets   st-15.dwg</small>				

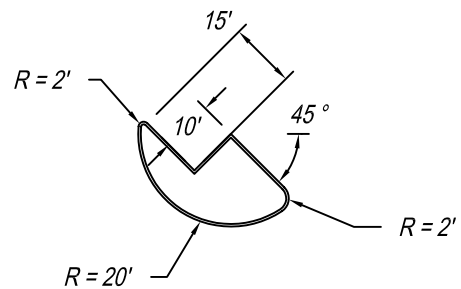
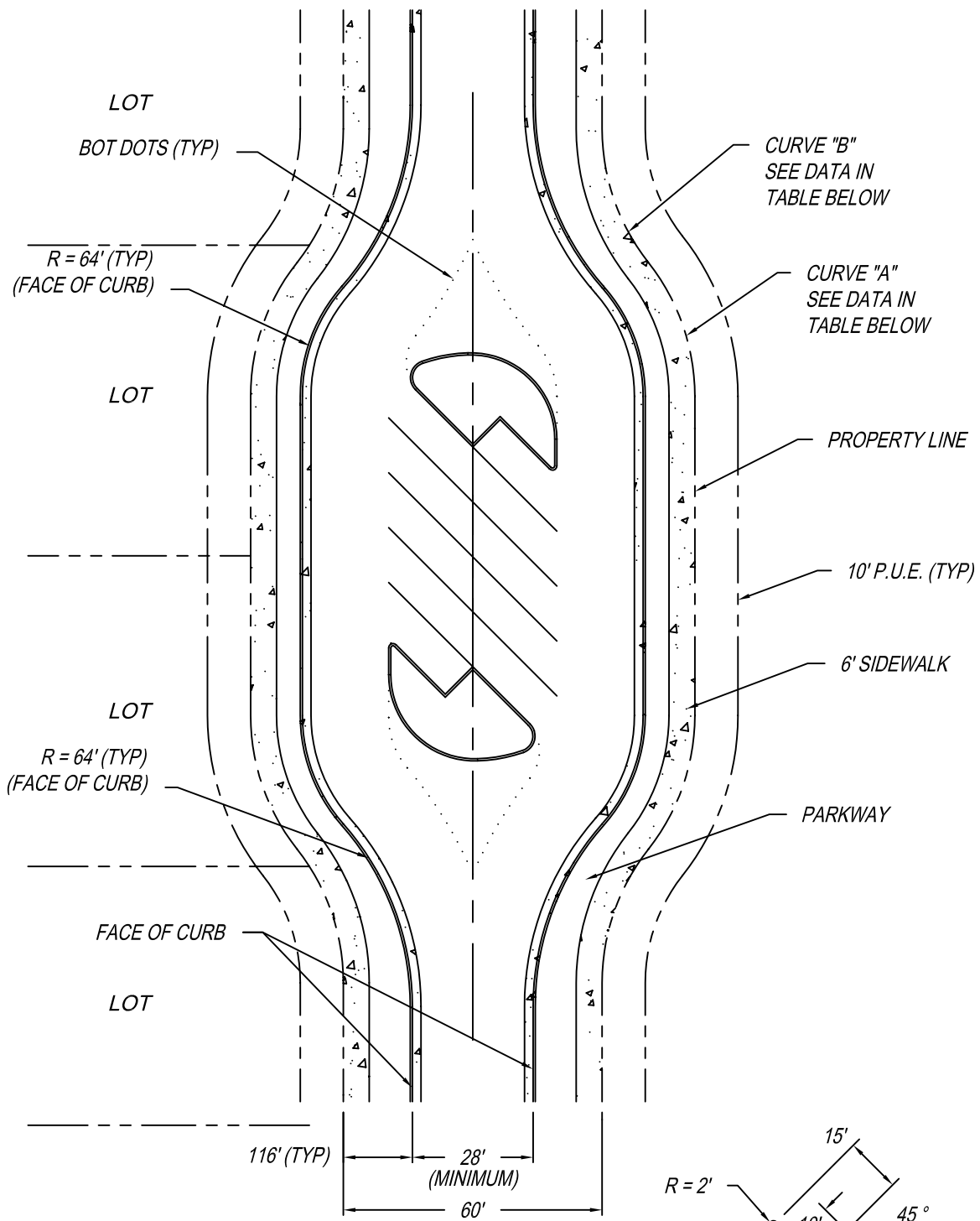

**ISLAND DETAIL**

R/W		CURVE A	CURVE B
60	R	60.00'	50.00'
	△	---	---
	ARC. L	---	---

\* PRIOR APPROVAL OR DIRECTION REQUIRED FROM THE CITY ENGINEER FOR USE OF THIS STANDARD.

NO.	REVISED	BY

DRAWN BY: TP

**Special  
Residential Parking**

APPROVED  
  
 CITY ENGINEER RCE-28191  
 DATE: 2-2-99

CHECKED BY: DJR  
 V:125 City of Ripon Standards | Standard Specifications | Drawings | Streets | st-16.dwg

**CITY OF RIPON**

STANDARD NO. **ST-16**

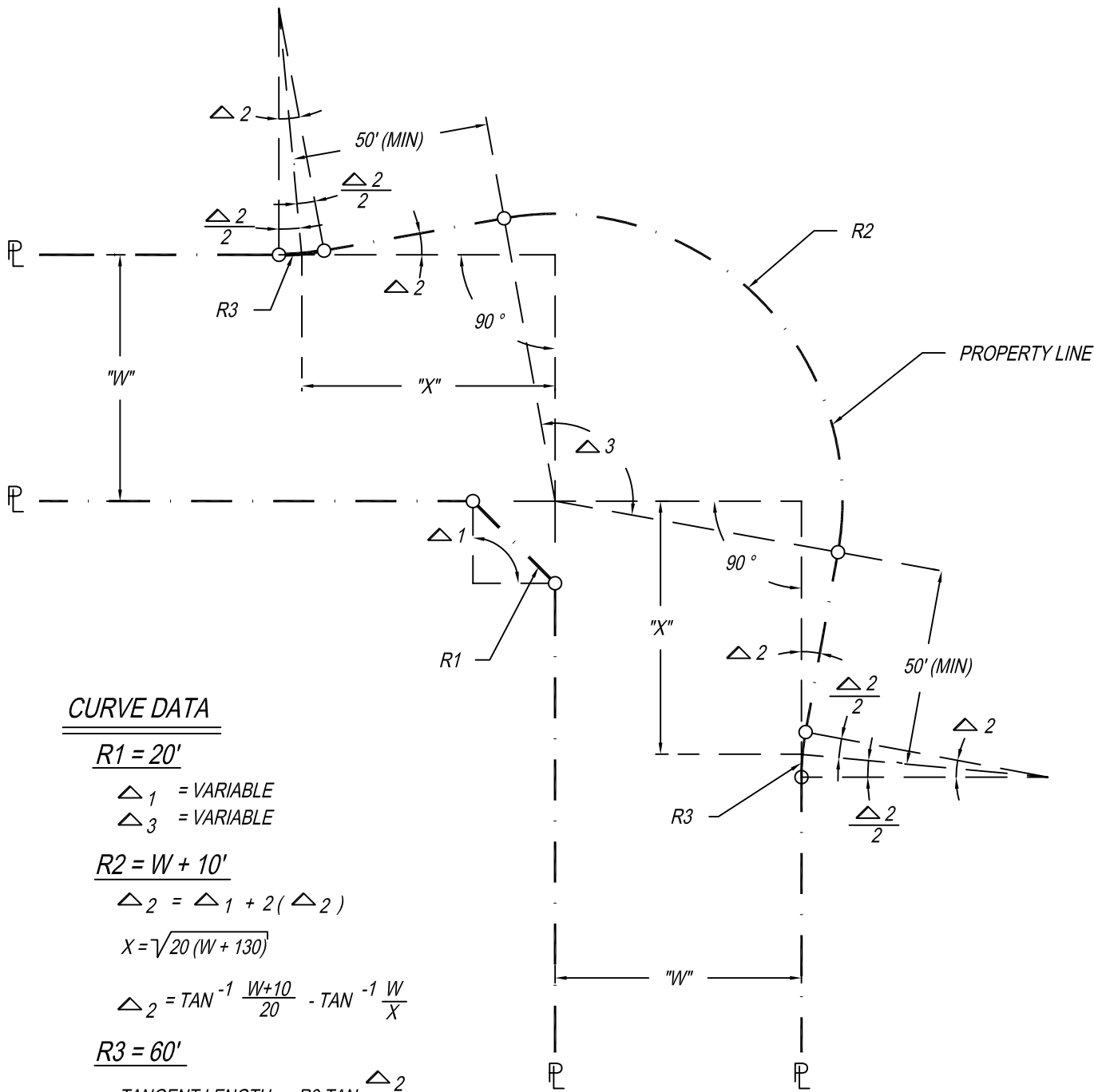

CURVE DATA

R1 = 20'

$\triangle_1 = \text{VARIABLE}$   
 $\triangle_3 = \text{VARIABLE}$

R2 = W + 10'

$\triangle_2 = \triangle_1 + 2(\triangle_2)$

$X = \sqrt{20(W + 130)}$

$\triangle_2 = \text{TAN}^{-1} \frac{W+10}{20} - \text{TAN}^{-1} \frac{W}{X}$

R3 = 60'

$\text{TANGENT LENGTH} = R3 \text{TAN} \frac{\triangle_2}{2}$

EXAMPLE

W	X	$\triangle_2$
60'	61.64'	10° 14' 11"

NOTES:

1. INTERSECTION BULBS ARE NOT REQUIRED ON STREETS WITH A CENTERLINE RADIUS OF 250' OR MORE.

NO.	REVISED	BY	<b>Alignment for 90° Plus Street Intersections</b>	APPROVED
				 CITY ENGINEER RCE-28191
				DATE: 2-2-99
DRAWN BY: MCP			<b>CITY OF RIPON</b>	STANDARD NO. <b>ST-17</b>
CHECKED BY: DJR				
<small>V:\125_City of Ripon Standards\Standard Specifications\Drawings\Streets\st-17.dwg</small>				

# PLACEMENT OF SCHOOL AREA PAVEMENT LEGENDS

**STOP:** SHALL BE LOCATED IN EACH APPROACH LANE 8 FEET IN ADVANCE OF THE STOP LIMIT LINE OR CROSSWALK LINE. LEGEND SHALL BE THERMOPLASTIC, UNLESS APPROVED OTHERWISE, IN WRITING, BY THE CITY ENGINEER.

**STOP AHEAD:** SHALL BE LOCATED IN EACH APPROACH LANE. THE STOP LEGEND SHALL BE AT THE (W17) STOP AHEAD SIGN, AND THE AHEAD LEGEND SHALL BE LOCATED NEARER TO THE STOP LIMIT LINE PER TABLE "A". BOTH LEGENDS SHALL BE THERMOPLASTIC, UNLESS APPROVED OTHERWISE, IN WRITING, BY THE CITY ENGINEER.

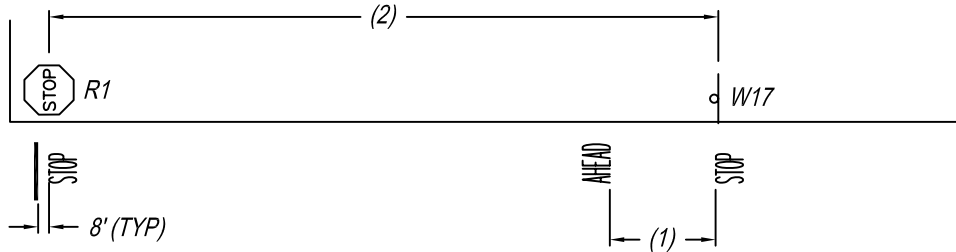
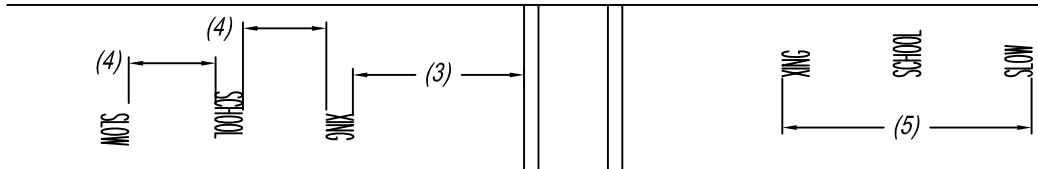

**TABLE "A"**

POSTED SPEED	SPACE BETWEEN LEGENDS (1)	SPACE BETWEEN R1 & W17 (2) *
25	32 FT	250 FT
30	40 FT	250 FT
35	48 FT	250 FT
40	56 FT	325 FT
45	64 FT	375 FT
50	72 FT	425 FT
55	80 FT	525 FT

\* DISTANCES DERIVED FROM CALTRANS HIGHWAY DESIGN MANUAL TABLE 201.1

**SLOW SCHOOL XING:** SHALL BE LOCATED IN EACH APPROACH LANE WITH THE LEGEND XING LOCATED PER TABLE "B". LEGEND SHALL BE THERMOPLASTIC, UNLESS APPROVED OTHERWISE, IN WRITING, BY THE CITY ENGINEER.



**TABLE "B"**

POSTED SPEED	DIST. FROM CROSSWALK (3)	SPACE BETWEEN LEGENDS (4)	OVERALL LEGEND LENGTH (5)
25	100 FT	32 FT	88 FT
30	150 FT	40 FT	104 FT
35	200 FT	48 FT	120 FT
40	260 FT	56 FT	136 FT
45	450 FT	64 FT	152 FT
50	500 FT	72 FT	168 FT
55	550 FT	80 FT	184 FT

NO.	REVISED	BY	<b>School Area Pavement Legends</b>	APPROVED  CITY ENGINEER RCE-28191
DRAWN BY: MCP				DATE: 2-2-99
CHECKED BY: DJR			<b>CITY OF RIPON</b>	STANDARD NO. <b>ST-18</b>
V: 1.25_City of Ripon Standards   Standard Specifications   Drawings   Streets   st-18.dwg				

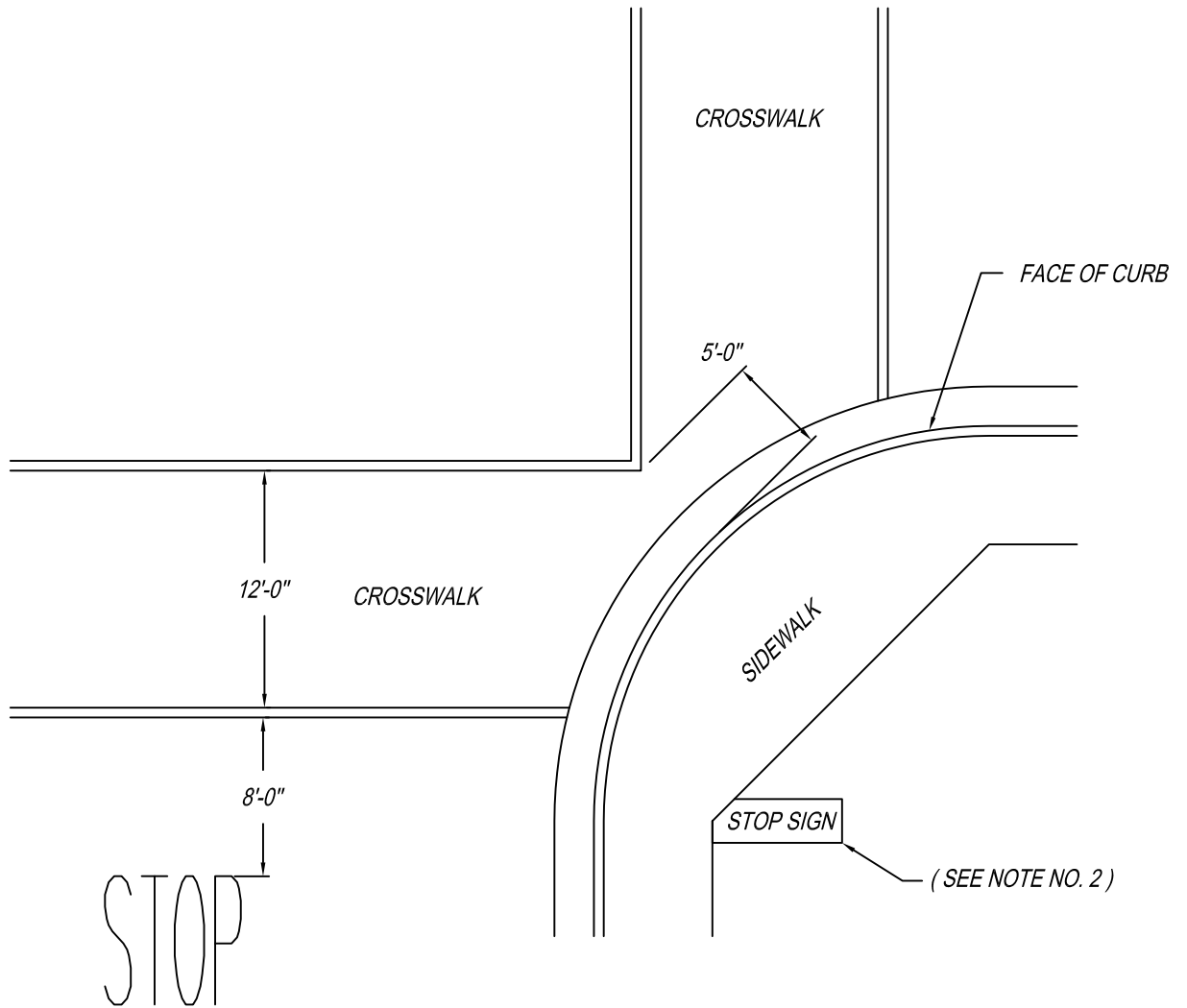

**NOTES:**

1. AN INTERSECTION NOT REQUIRING CROSSWALKS SHALL HAVE A STOP BAR PLACED IN THE SAME LOCATION AS THE CROSSWALK LINE CLOSEST TO THE LEGEND.
2. STOP SIGN INSTALLATION SHALL BE AT THE BACK OF WALK AT THE CURB RETURN OR AS DIRECTED BY THE CITY ENGINEER.
3. ALL STRIPING AND LEGENDS SHALL BE THERMOPLASTIC, UNLESS APPROVED OTHERWISE, IN WRITING, BY THE CITY ENGINEER.

NO.	REVISED	BY	<b>Crosswalk / Stop Bar Placement</b>	APPROVED
				<i>[Signature]</i>
				CITY ENGINEER RCE-28191
DRAWN BY: MCP				DATE: 2-2-99
CHECKED BY: DJR			<b>CITY OF RIPON</b>	STANDARD NO. <b>ST-19</b>
V: 1.25_City of Ripon Standards   Standard Specifications   Drawings   Streets   st-19.dwg				

## Concrete Curb, Gutter and Sidewalk Construction Notes

1. Curb and gutter construction shall conform to Section 73, California Department of Transportation Standard Specifications, except as modified herein.
2. Reference is made to Section 13 of the City of Ripon Standard Specifications for requirements relating to the construction of concrete curb, gutter, and sidewalk.
3. Subgrade for curb, gutter and sidewalk shall be compacted to a minimum relative compaction of 95% to a depth of 8" (inches). Where the subgrade "R" value is less than 50, place 4" (inches) of aggregate sub-base under the concrete sections and compact to a minimum of 95%.
4. All concrete radii are 3/4" unless noted.
5. Concrete shall be Class B, per CALTRANS Section 90. One pound of lampblack shall be added per cubic yard of concrete.
6. Expansion joints and weakened plane joints shall be installed as indicated on the plans or standard details.
7. Curb, gutter and sidewalk shall have a light broom finish.
8. Depress a 2" high letter "W", "NP" or "S" 1/4" deep into the face of the curb to identify service locations. Letters to be placed as read from the street.
9. During construction of gutters, water test the flow to insure proper drainage.

NO.	REVISED	BY	<b>Concrete Curb, Gutter and Sidewalk Standards</b>	APPROVED
				 CITY ENGINEER RCE-28191
				DATE: 2-2-99
DRAWN BY: Matt			<b>CITY OF RIPON</b>	STANDARD NO. <b>ST-20</b>
CHECKED BY: DJR				
<small>V:\25_City of Ripon Standards\Standard Specifications\Drawings\Streets\st-20.dwg</small>				



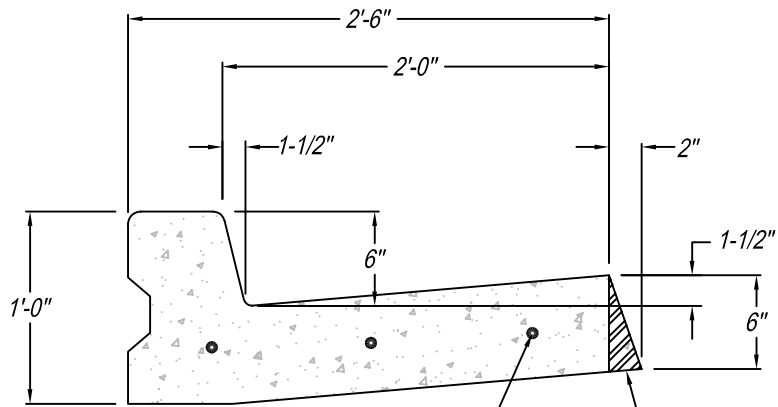

THREE (3) 5/8" x 24" LONG STEEL DOWELS  
GREASED AND WRAPPED, ONE SIDE,  
THRU EVERY EXPANSION JOINT. (TYP)

SEE NOTE 6

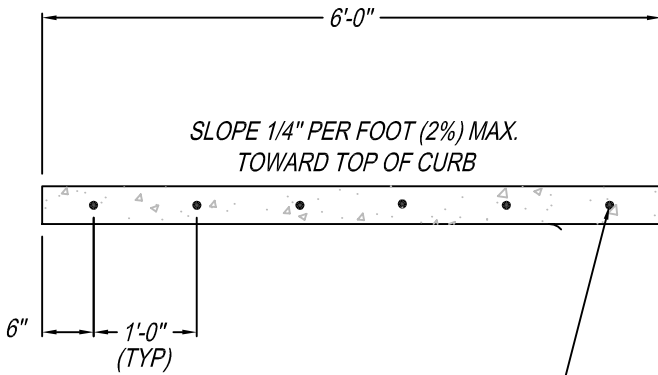

SIX (6) 5/8" x 24" LONG STEEL DOWELS  
GREASED AND WRAPPED, ONE SIDE,  
THRU EVERY EXPANSION JOINT. (TYP)

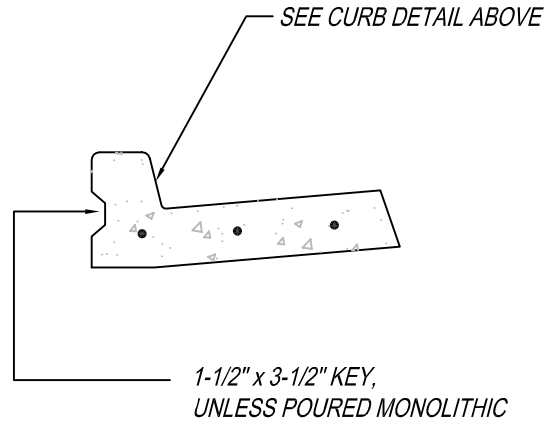

1-1/2" x 3-1/2" KEY,  
UNLESS POURED MONOLITHIC

## NOTES

1. FINE HAIR BRUSH FINISH ON CURB, GUTTER, AND SIDEWALK.
2. CONSTRUCTION SHALL BE IN ACCORDANCE WITH THE APPLICABLE SECTIONS OF THE CURRENT CITY OF RIPON SPECIFICATIONS.
3. CONSTRUCT EXPANSION JOINTS 200' C.C. MAXIMUM, AT CURB RETURNS, AT CATCH BASINS, AND AT BOTH SIDES OF DRIVEWAYS.
4. MATERIAL UNDER SIDEWALK AND GUTTER SHALL BE COMPACTED TO 95% RELATIVE COMPACTION FOR A DEPTH OF 8".
5. IN THE SIDEWALK AREA, TRANSVERSE SCORE MARKS SHALL BE SPACED AT 6' ON CENTER.
6. CONCRETE PAVER STREETS WILL HAVE A VERTICAL GUTTER REVEAL.

NO.	REVISED	BY	<b>6" Vertical Curb, Gutter, and Sidewalk</b>	APPROVED
				<i>[Signature]</i> CITY ENGINEER RCE-28191
				DATE: 2-2-99
DRAWN BY: MCP			<b>CITY OF RIPON</b>	STANDARD NO. <b>ST-21</b>
CHECKED BY: DJR				
V:\25_City of Ripon Standards\Standard Specifications\Drawings\Streets\st-21.dwg				

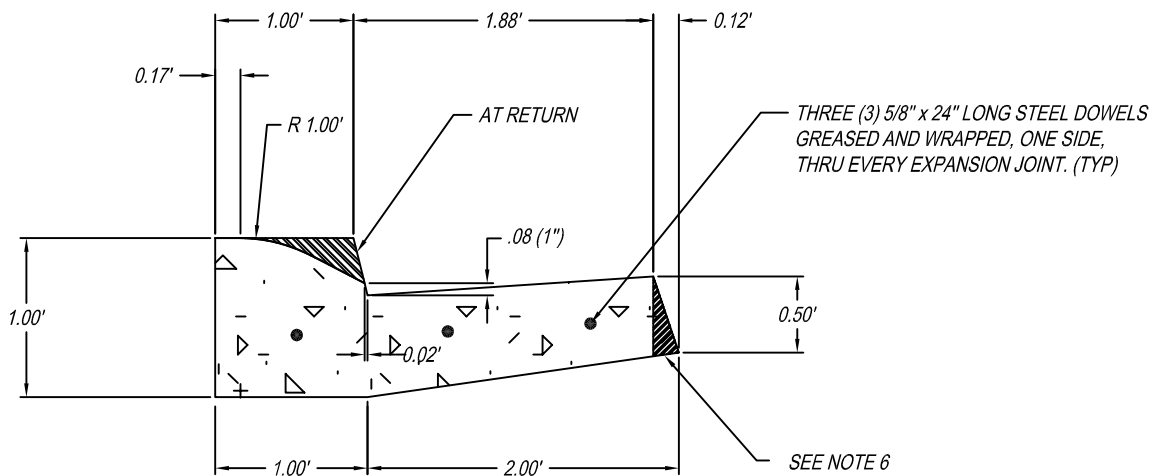
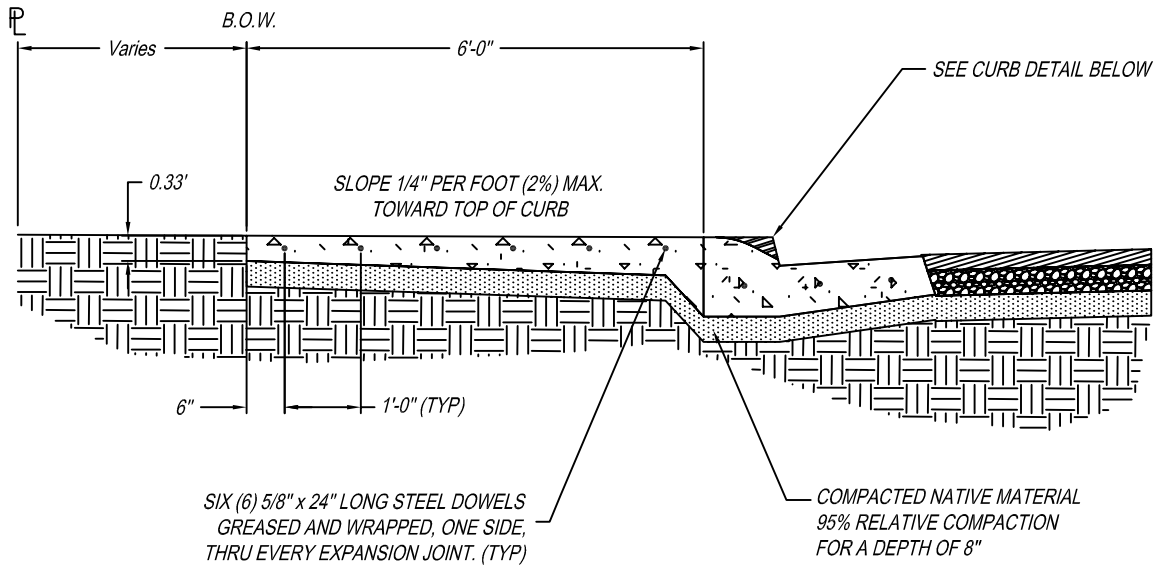

### DRIVE-OVER CURB DETAIL

### NOTES

1. FINE HAIR BROOM FINISH ON CURB, GUTTER, AND SIDEWALK.
2. CONSTRUCTION SHALL BE IN ACCORDANCE WITH THE APPLICABLE SECTIONS OF THE CURRENT CITY OF RIPON SPECIFICATIONS.
3. CONSTRUCT EXPANSION JOINTS 200' C.C. MAXIMUM, AT CURB RETURNS, AT CATCH BASINS, AND AT BOTH SIDES OF DRIVEWAYS.
4. MATERIAL UNDER SIDEWALK AND GUTTER SHALL BE COMPACTED TO 95% RELATIVE COMPACTION FOR A DEPTH OF 8".
5. IN THE SIDEWALK AREA, TRANSVERSE SCORE MARKS SHALL BE SPACED AT 6' ON CENTER.
6. CONCRETE PAVER STREETS WILL HAVE A VERTICAL GUTTER REVEAL.

NO.	REVISED	BY	<b>4-1/2" Drive-Over Curb, Gutter, and Sidewalk</b>	APPROVED
				 CITY ENGINEER RCE-28191
				DATE: 2-2-99
DRAWN BY: MCP			<b>CITY OF RIPON</b>	STANDARD NO. <b>ST-21a</b>
CHECKED BY: DJR				
V:\25 City of Ripon Standards\Standard Specifications\Drawings\Streets\st-21a.dwg				

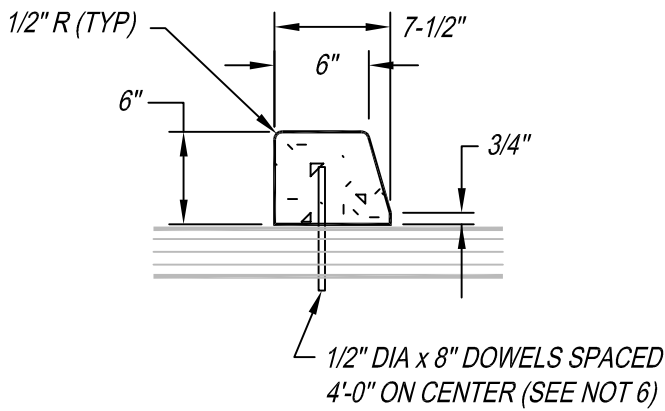

**TYPE "E" CURB**

FOR USE ON TRAFFIC ISLANDS  
IN EXISTING STREETS ONLY

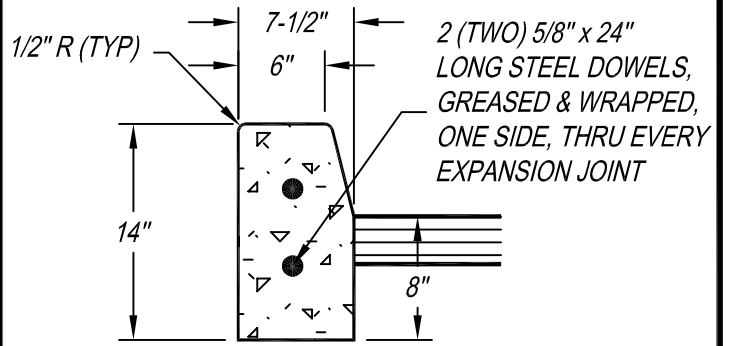

**TYPE "D" CURB**

SHALL BE USED FOR HIGH SIDE OF FRONTAGE  
ROADS AND TRAFFIC ISLANDS IN NEW STREETS

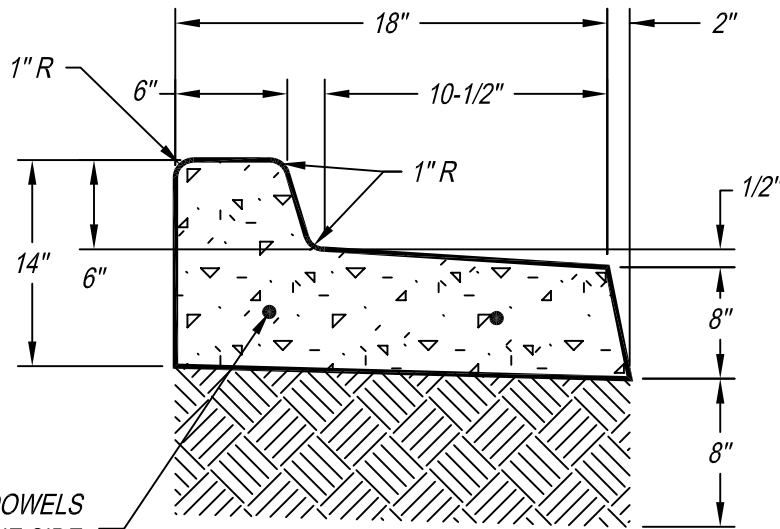

2 (TWO) 5/8" x 24" LONG STEEL DOWELS  
GREASED AND WRAPPED, ONE SIDE,  
THRU EVERY EXPANSION JOINT

**TYPE "C" CURB AND APRON  
FOR USE ON MEDIANS**

**NOTES:**

1. FINE HAIR BROOM FINISH ON CURB AND GUTTER.
2. CONSTRUCTION SHALL BE IN ACCORDANCE WITH THE APPLICABLE SECTIONS OF THE CURRENT CITY OF RIPON SPECIFICATIONS.
3. CONSTRUCT EXPANSION JOINTS 200 FT CENTER TO CENTER MAXIMUM, AT CURB RETURNS, AT CATCH BASINS, AND AT BOTH SIDES OF DRIVEWAYS.
4. MATERIAL UNDER CURB AND GUTTER SHALL BE COMPACTED TO 95% RELATIVE COMPACTION FOR A DEPTH OF 8".
5. FOR ANCHORING TYPE "E" CURB TO SURFACE SEE SECTION 73-1.05 B OF THE CALTRANS STANDARD SPECIFICATIONS.
6. SIDEWALK PLACED BEHIND TYPE C CURB AND GUTTER SHALL BE 6'-0" MINIMUM WIDTH.
7. MINIMUM GUTTER SLOPE SHALL BE 0.0033.

NO.	REVISED	BY
DRAWN BY: MCP		
CHECKED BY: DJR		
V:\125_City of Ripon Standards\Standard Specifications\Drawings\Streets\st-21b.dwg		

**Type "C", "D" and "E"  
Curb and Gutter**

**CITY OF RIPON**

APPROVED

*[Signature]*

CITY ENGINEER RCE-28191

DATE: 2-2-99

STANDARD NO. **ST-21b**

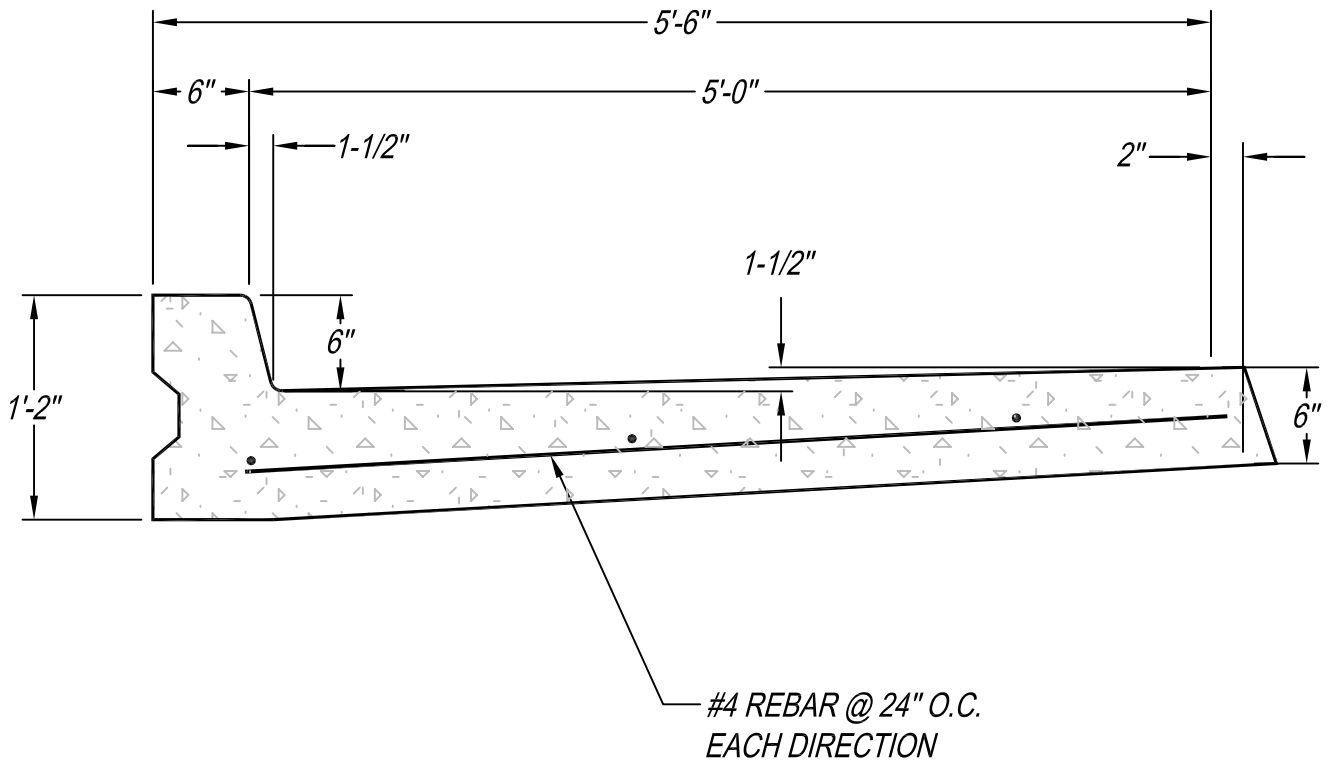

## NOTES

1. FINE HAIR BROOM FINISH ON CURB, GUTTER, AND SIDEWALK.
2. CONSTRUCTION SHALL BE IN ACCORDANCE WITH THE APPLICABLE SECTIONS OF THE CURRENT CITY OF RIPON SPECIFICATIONS.
3. CONSTRUCT EXPANSION JOINTS 200' C.C. MAXIMUM, AT CURB RETURNS, AT CATCH BASINS, AND AT BOTH SIDES OF DRIVEWAYS.
4. MATERIAL UNDER SIDEWALK AND GUTTER SHALL BE COMPACTED TO 95 % RELATIVE COMPACTION FOR A DEPTH OF 8".
5. IN THE SIDEWALK AREA, TRANSVERSE SCORE MARKS SHALL BE SPACED AT 6' ON CENTER.
6. 5 (FIVE) 5/8" x 24" LONG STEEL DOWELS GREASED AND WRAPPED, ONE SIDE, THRU EVERY EXPANSION JOINT.

NO.	REVISED	BY	<b>Class II Bicycle Path and Gutter Pan</b>	APPROVED
				<i>Matt MacDade</i> CITY ENGINEER RCE-58093
				DATE: 12-4-2001
DRAWN BY: MCP			<b>CITY OF RIPON</b>	STANDARD NO. <b>ST-21c</b>
CHECKED BY: MJM				
V:\125_City of Ripon Standards\Standard Specifications\Drawings\Streets\st-21c.dwg				

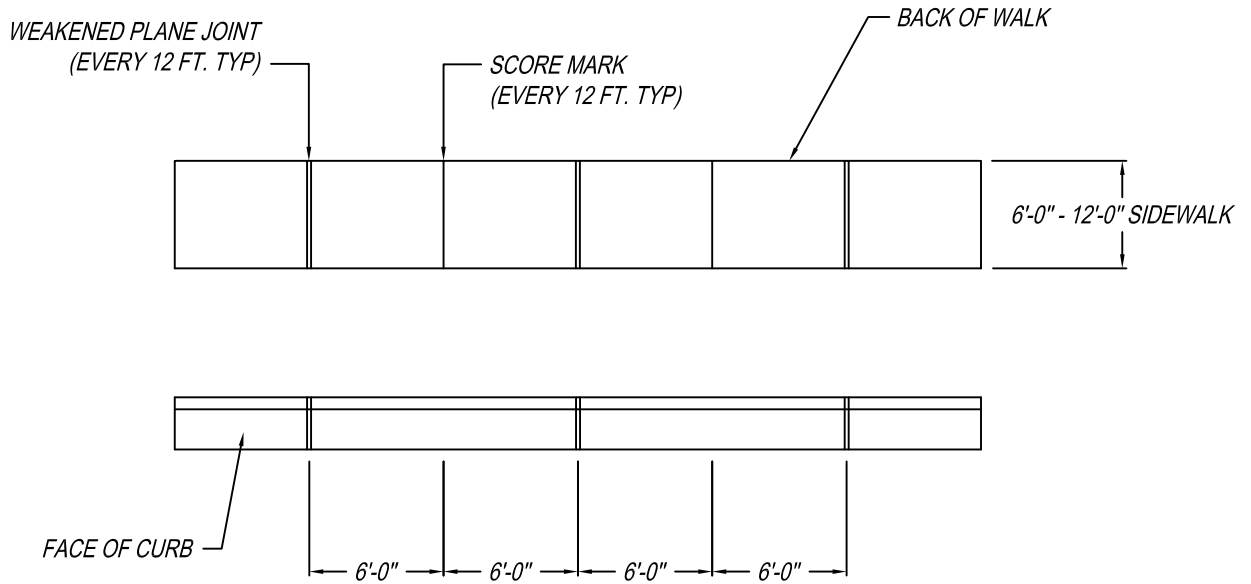

PLAN

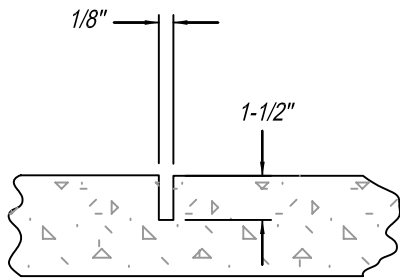

WEAKENED PLANE JOINT

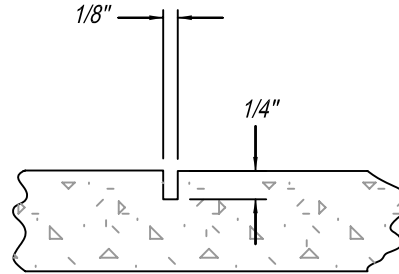

SCORE MARK

NOTE

1. CONSTRUCT WEAKENED PLANE JOINT EVERY 12 FEET.

NO.	REVISED	BY	<b>Location of Weakened Plane Joints</b>	APPROVED
				
				CITY ENGINEER RCE-28191
DRAWN BY: MCP				DATE: 2-2-99
CHECKED BY: DJR			<b>CITY OF RIPON</b>	STANDARD NO. <b>ST-22</b>
V:\25_City of Ripon Standards\Standard Specifications\Drawings\Streets\st-22.dwg				

WEAKENED PLANE JOINTS AND SCORE MARKS IN SIDEWALK PER CITY OF RIPON STANDARD ST-22. (WILL NOT NECESSARILY LINE UP WITH DRIVEWAY WEAKENED PLANE JOINTS)

WEAKENED PLANE JOINT ON C.L. OF DRIVEWAY AND EDGES OF WARP MINIMUM (TYP)

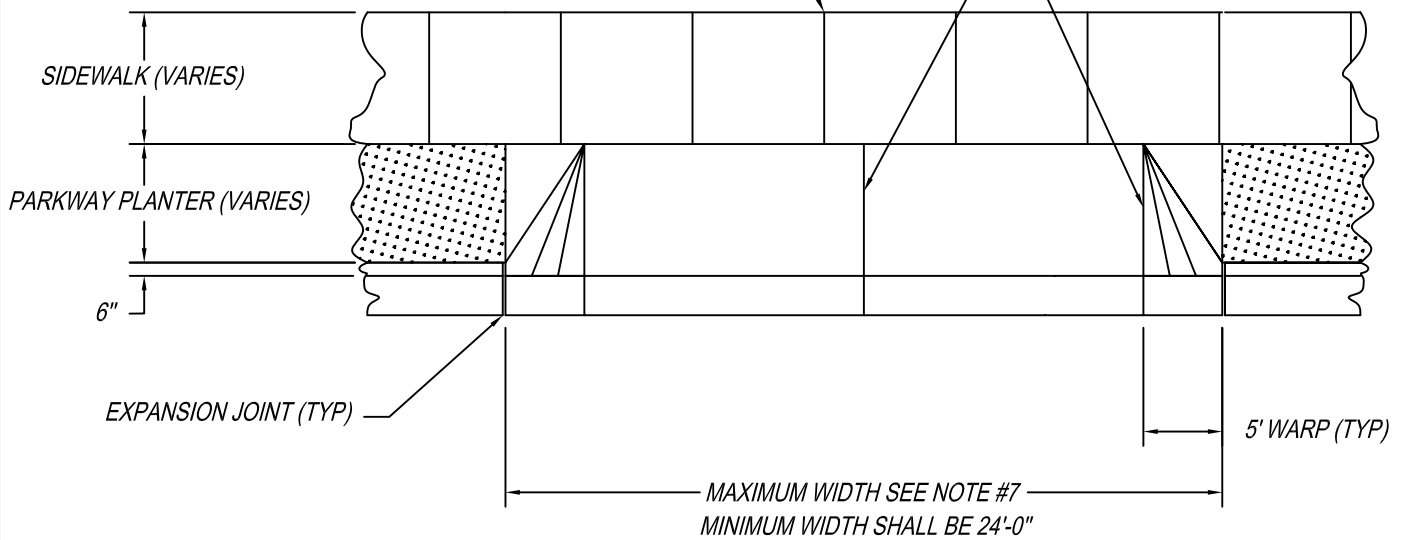

PLAN VIEW

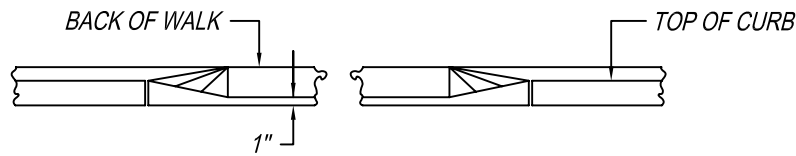

FRONT ELEVATION

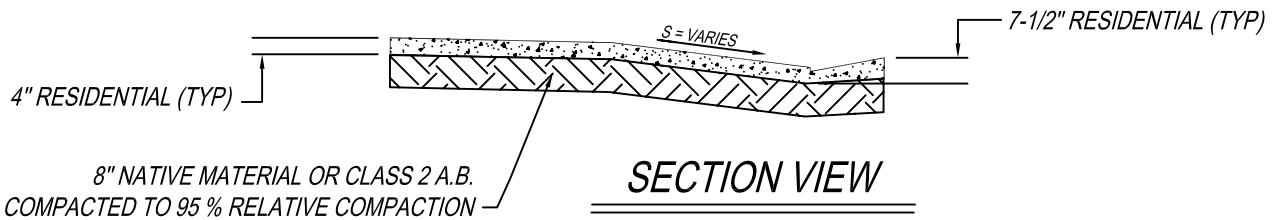

SECTION VIEW

NOTES

1. DRIVEWAYS TO CONFORM WITH EXISTING SIDEWALKS.
2. THE SIDEWALK MAY FORM PART OF THE DRIVEWAY, IF IN GOOD CONDITION.
3. DRIVEWAY RAMP SHALL BE AS WIDE AS EXISTING DRIVEWAY INTO PROPERTY, ROUNDED UP TO THE NEXT EVEN FOOT. (10' MIN.)
4. IN THE EVENT OF AN OBSTRUCTION IN PARKWAY (POWER POLE, ETC.) WIDTH MAY BE MODIFIED TO MEET EXISTING CONDITIONS. (MUST BE APPROVED BY CITY ENGINEER AND/OR CITY PLANNER).
5. WHEN IT IS NOT POSSIBLE TO PROVIDE 2' OF FULL CURB HEIGHT (WITH STANDARD 5' WARPS ON EITHER SIDE) BETWEEN ADJACENT DRIVEWAYS, A COMMON DRIVEWAY SHALL BE INSTALLED.
6. FINE HAIR BROOM FINISH ON ALL DRIVEWAYS.
7. 33 FT MAX WIDTH OR 45 % OF LOT WIDTH, WHICHEVER IS GREATER. DRIVEWAY APPROACH MUST BE CONNECTED TO A CONCRETE DRIVEWAY.
8. FOR CONSTRUCTION OF NEW DRIVEWAY IN EXISTING CURB AND GUTTER, MUST SAW CUT AND REMOVE A.C. 2 FT FROM LIP OF GUTTER, CONSTRUCT NEW DRIVEWAY, AND PATCH BACK A.C. UP AGAINST NEW LIP OF GUTTER ENSURING TO TACK THE LIP OF GUTTER PRIOR TO PAVING.

NO.	REVISED	BY
DRAWN BY: MCP		
CHECKED BY: MJM		
V:\25_City of Ripon Standards\Standard Specifications\Drawings\Streets\st-23.dwg		

**Standard Residential  
Driveway with Vertical  
Curb and Detached Sidewalk**

**CITY OF RIPON**

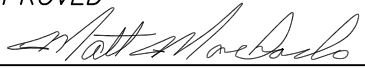
APPROVED  
  
 CITY ENGINEER RCE-58093  
 DATE: 12-4-2001  
 STANDARD NO. **ST-23**

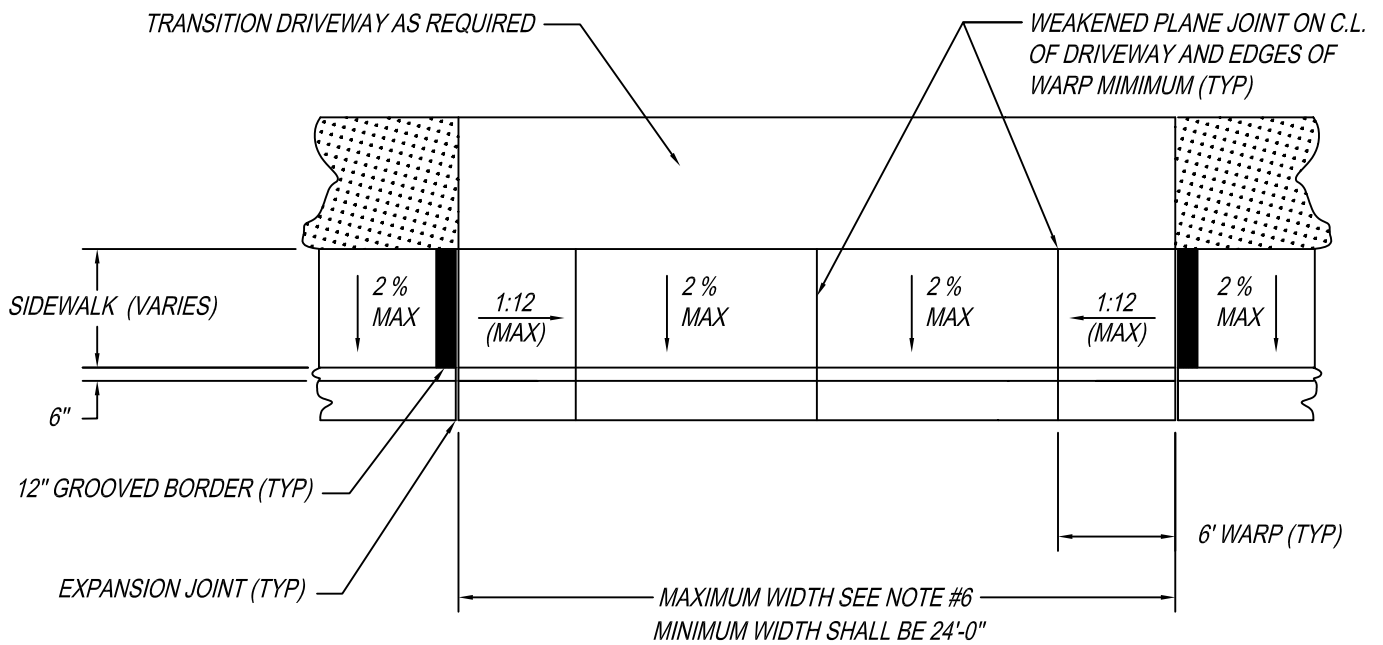

**PLAN VIEW**

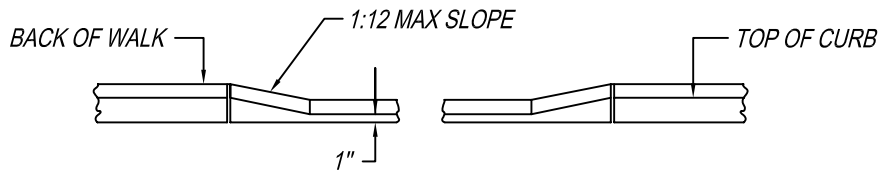

**FRONT ELEVATION**

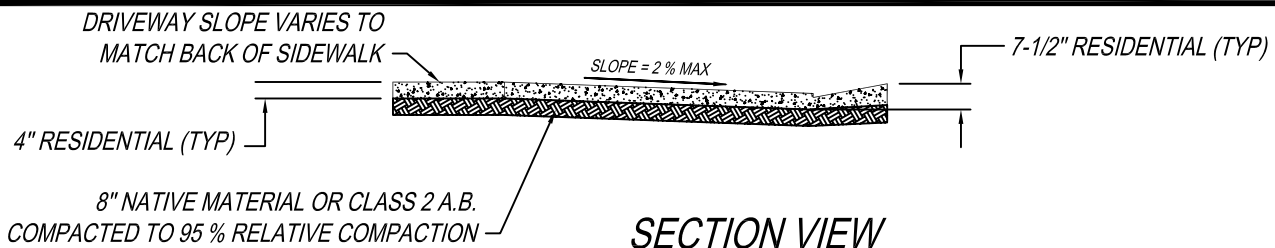

**SECTION VIEW**

**NOTES**

1. DRIVEWAYS TO CONFORM WITH EXISTING SIDEWALKS.
2. DRIVEWAY RAMP SHALL BE AS WIDE AS EXISTING DRIVEWAY INTO PROPERTY, ROUNDED UP TO THE NEXT EVEN FOOT. (10' MIN.)
3. IN THE EVENT OF AN OBSTRUCTION, (POWER POLE, ETC.) WIDTH MAY BE MODIFIED TO MEET EXISTING CONDITIONS. (MUST BE APPROVED BY CITY ENGINEER AND/OR CITY PLANNER).
4. WHEN IT IS NOT POSSIBLE TO PROVIDE 2' OF FULL CURB HEIGHT (WITH STANDARD 6' WARPS ON EITHER SIDE) BETWEEN ADJACENT DRIVEWAYS, A COMMON DRIVEWAY SHALL BE INSTALLED.
5. FINE HAIR BROOM FINISH ON ALL DRIVEWAYS.
6. 33 FT MAX WIDTH OR 45 % OF LOT WIDTH, WHICHEVER IS GREATER. DRIVEWAY APPROACH MUST BE CONNECTED TO A CONCRETE DRIVEWAY.
7. FOR CONSTRUCTION OF NEW DRIVEWAY IN EXISTING CURB AND GUTTER, MUST SAW CUT AND REMOVE A.C. 2 FT FROM LIP OF GUTTER, CONSTRUCT NEW DRIVEWAY, AND PATCH BACK A.C. UP AGAINST NEW LIP OF GUTTER ENSURING TO TACK THE LIP OF GUTTER PRIOR TO PAVING.

NO.	REVISED	BY	<b>Standard Residential/Commercial Driveway with Vertical Curb and Attached Sidewalk</b>	APPROVED
				 CITY ENGINEER RCE-58093
				DATE: 12-4-2001
DRAWN BY: MCP			<b>CITY OF RIPON</b>	STANDARD NO. <b>ST-23a</b>
CHECKED BY: MJM				
V:\125_City of Ripon Standards\Standard Specifications\Drawings\Streets\st-23a.dwg				

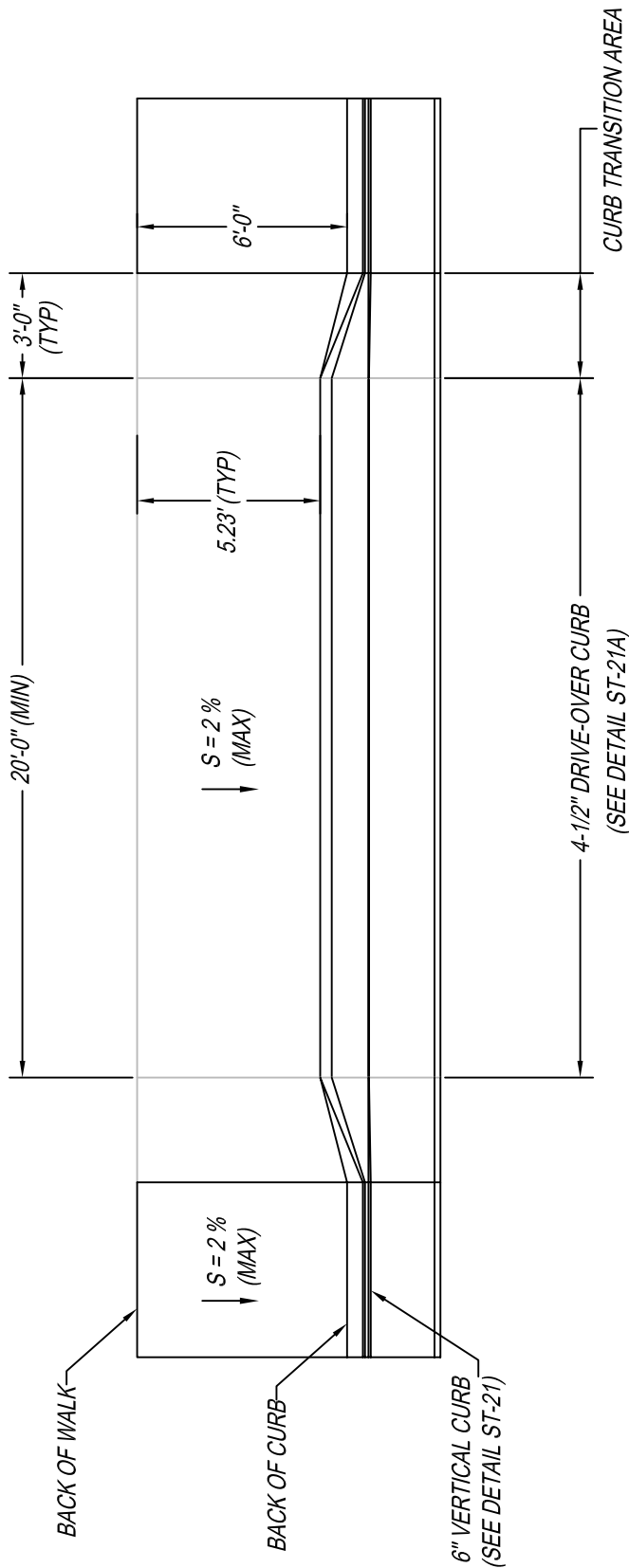

# DRIVEWAY PLANVIEW

\* PRIOR APPROVAL OR DIRECTION REQUIRED FROM THE CITY ENGINEER FOR USE OF THIS STANDARD.

NO.	REVISED	BY	<b>Special Driveway Detail</b> <b>Drive-Over Curb Approach</b> <b>with 6" Vertical Curb</b>	APPROVED
				 CITY ENGINEER RCE-28191
				DATE: 2-2-99
DRAWN BY: MCP			<b>CITY OF RIPON</b>	STANDARD NO. <b>ST-23b</b>
CHECKED BY: DJR				
V: 125 City of Ripon Standards   Standard Specifications   Drawings   Streets   st-23b.dwg				



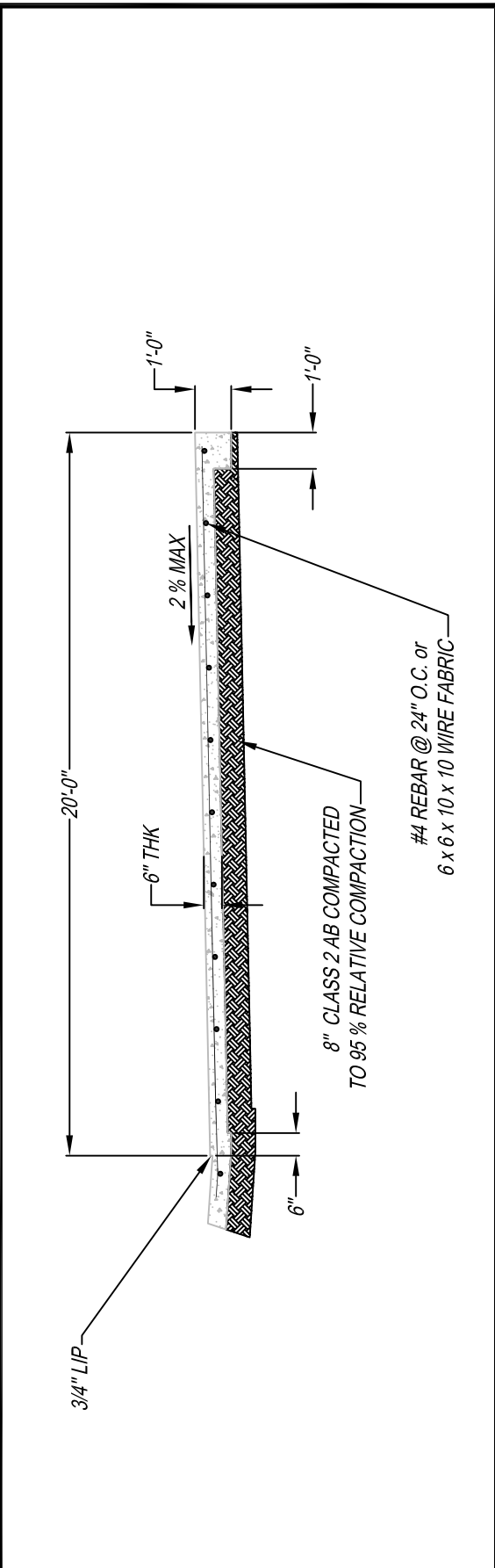
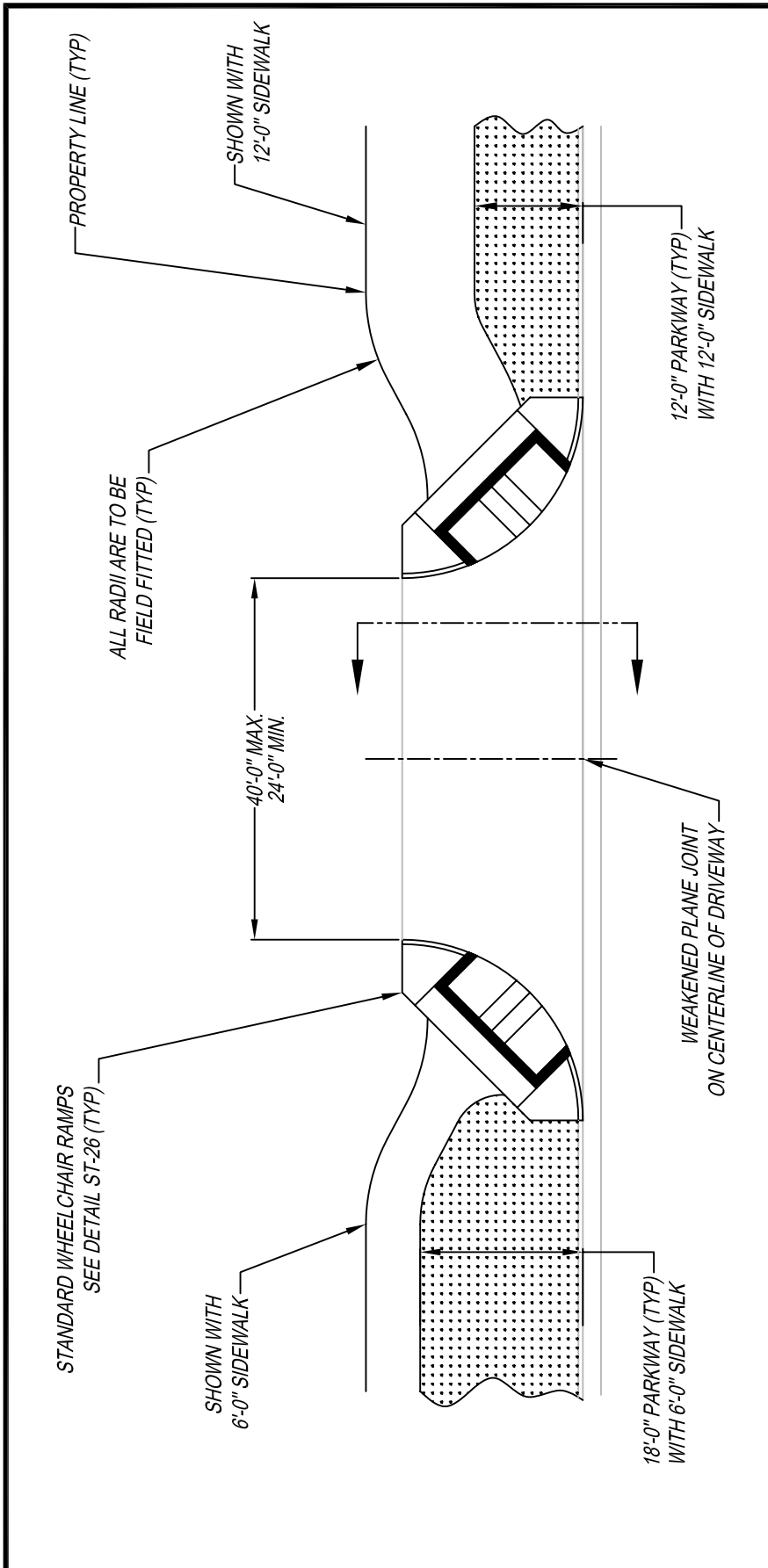

NO.	REVISED	BY
DRAWN BY: MCP		
CHECKED BY: MJM		
V:\125_City of Ripon Standards\Standard Specifications\Drawings\Streets\st-24.dwg		

**140' Major Arterial  
Commercial Driveway  
with Detached Sidewalk**

**CITY OF RIPON**

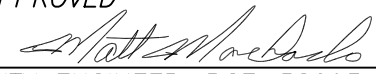
APPROVED  
  
 CITY ENGINEER RCE-58093  
 DATE: 12-4-2001

STANDARD NO. **ST-24**

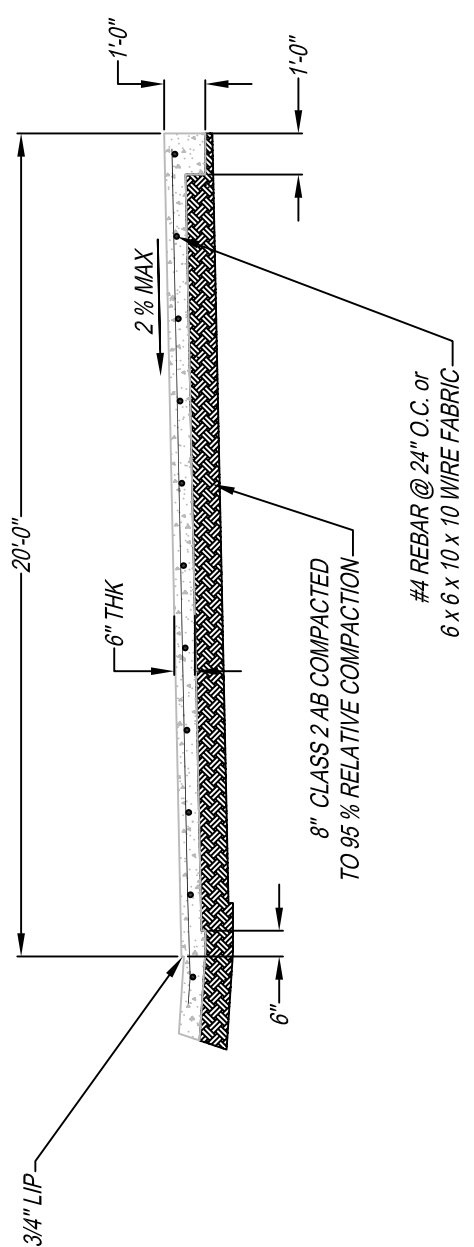
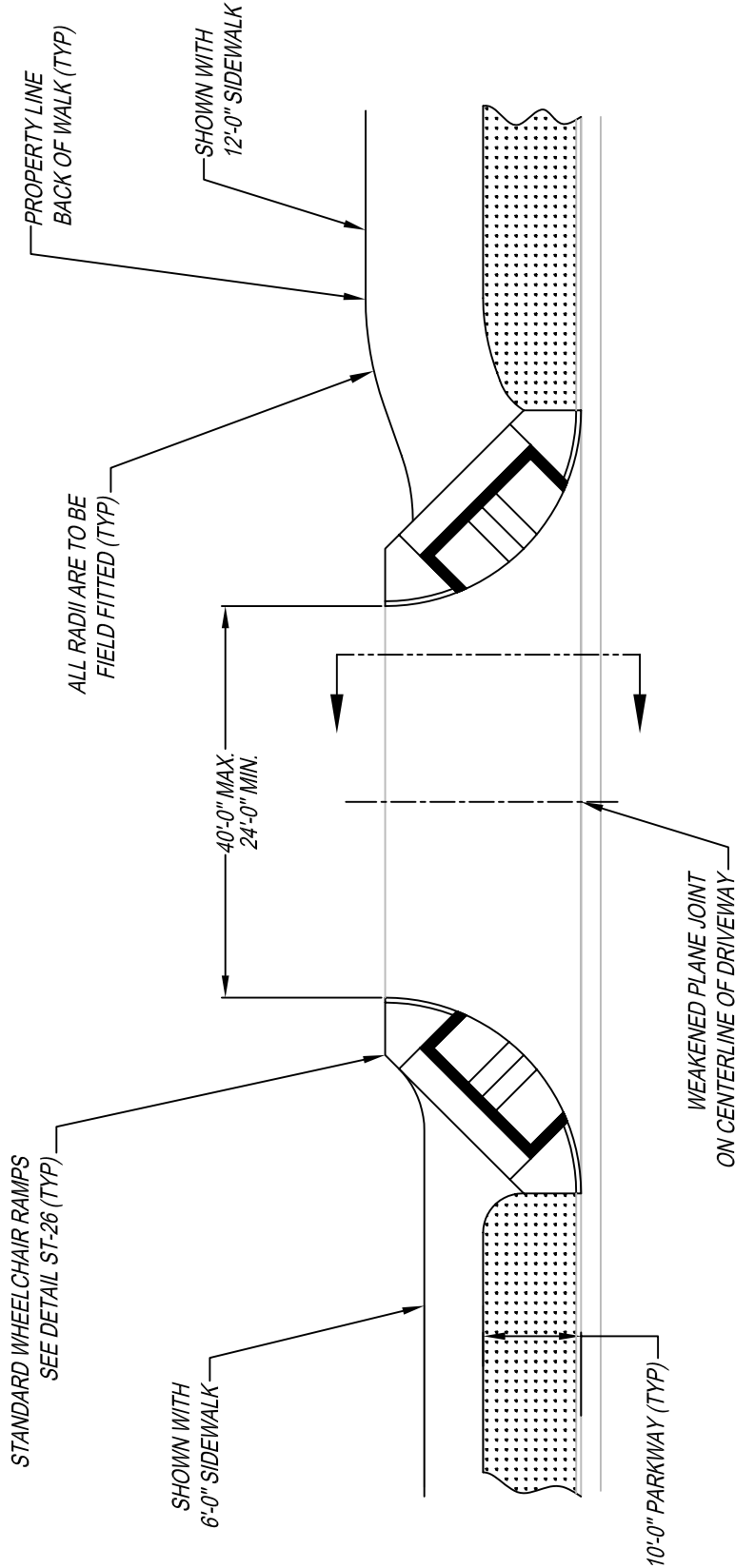

NO.	REVISED	BY
DRAWN BY: MCP		
CHECKED BY: MJM		
V:\125_City of Ripon Standards\Standard Specifications\Drawings\Streets\st-24a.dwg		

**102' Minor Arterial  
Commercial Driveway  
with Detached Sidewalk**

**CITY OF RIPON**

APPROVED  
*Matthew MacEachron*  
CITY ENGINEER RCE-58093  
DATE: 12-4-2001  
STANDARD NO. **ST-24a**

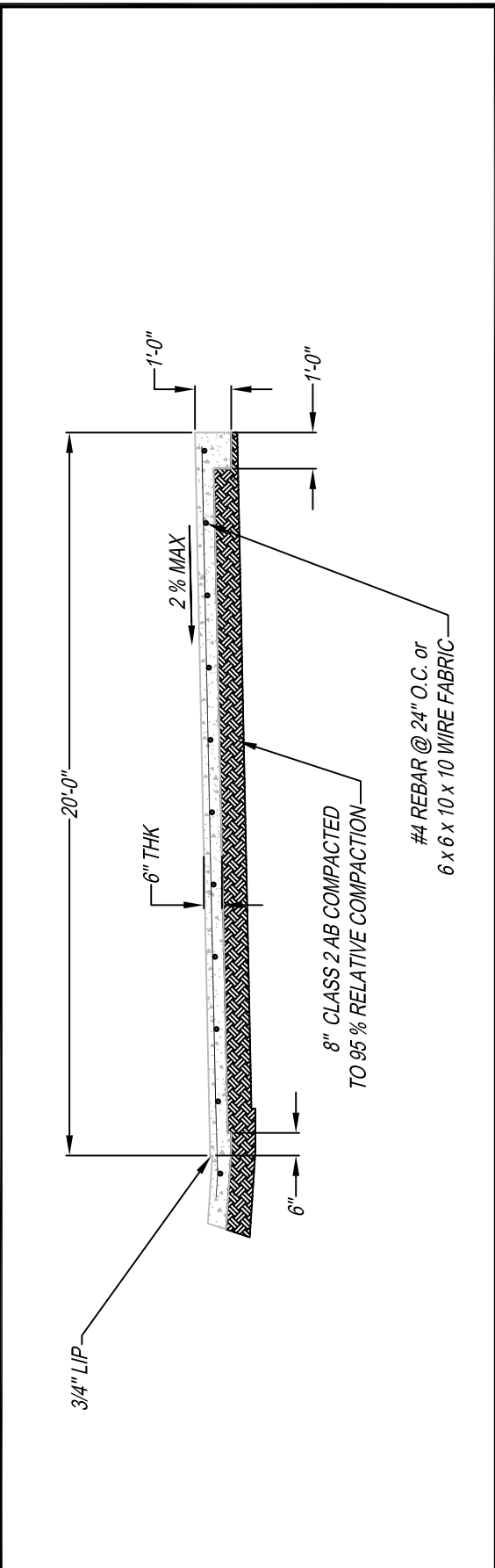
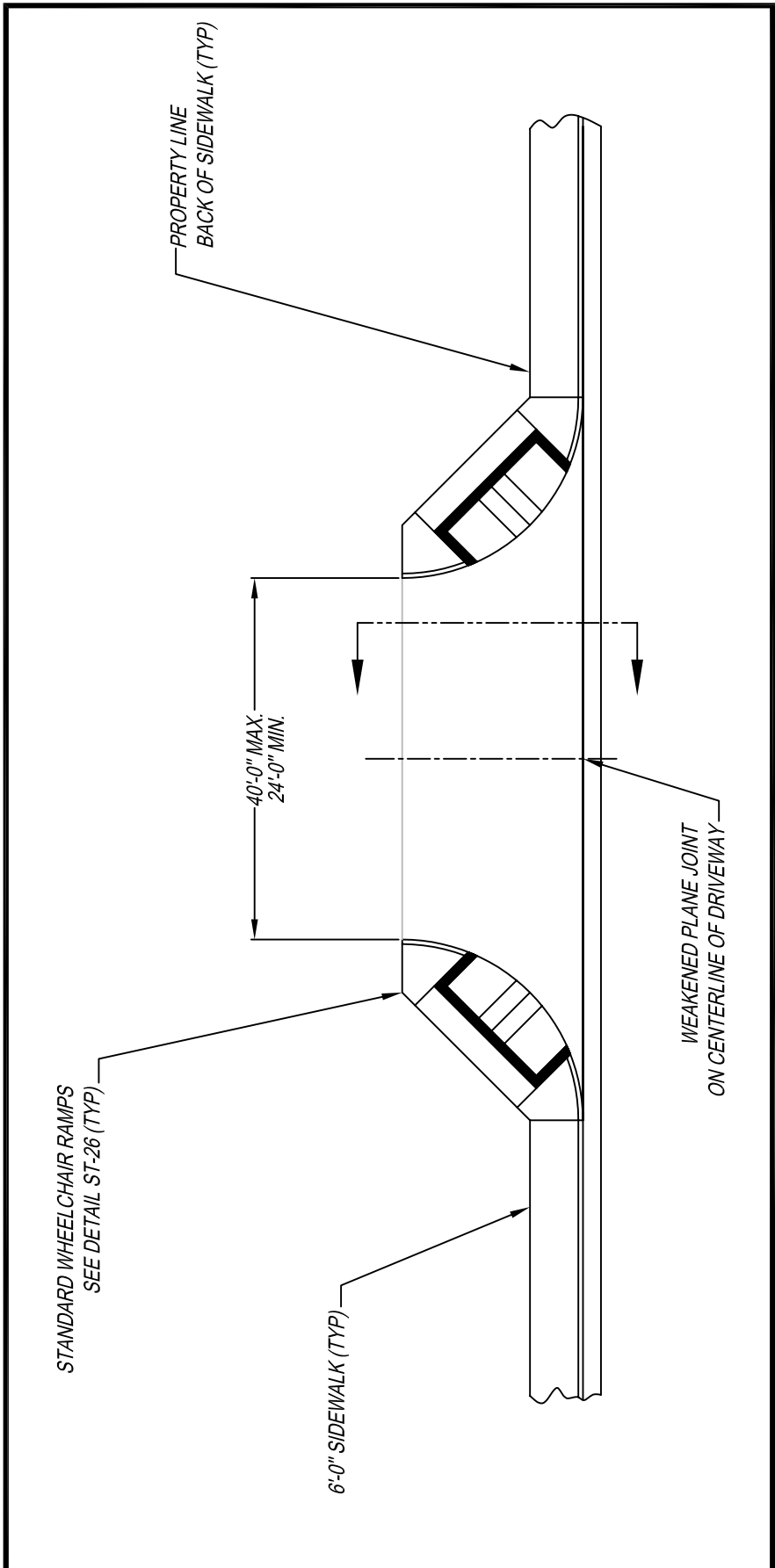

NO.	REVISED	BY
DRAWN BY: MCP		
CHECKED BY: MJM		
V:\125_City of Ripon Standards\Standard Specifications\Drawings\Streets\st-24b.dwg		

**82' and 74' Street R.O.W.  
Commercial Driveway  
with Detached Sidewalk**

**CITY OF RIPON**

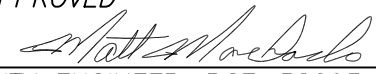
APPROVED  
  
 CITY ENGINEER RCE-58093  
 DATE: 12-4-2001  
 STANDARD NO. **ST-24b**

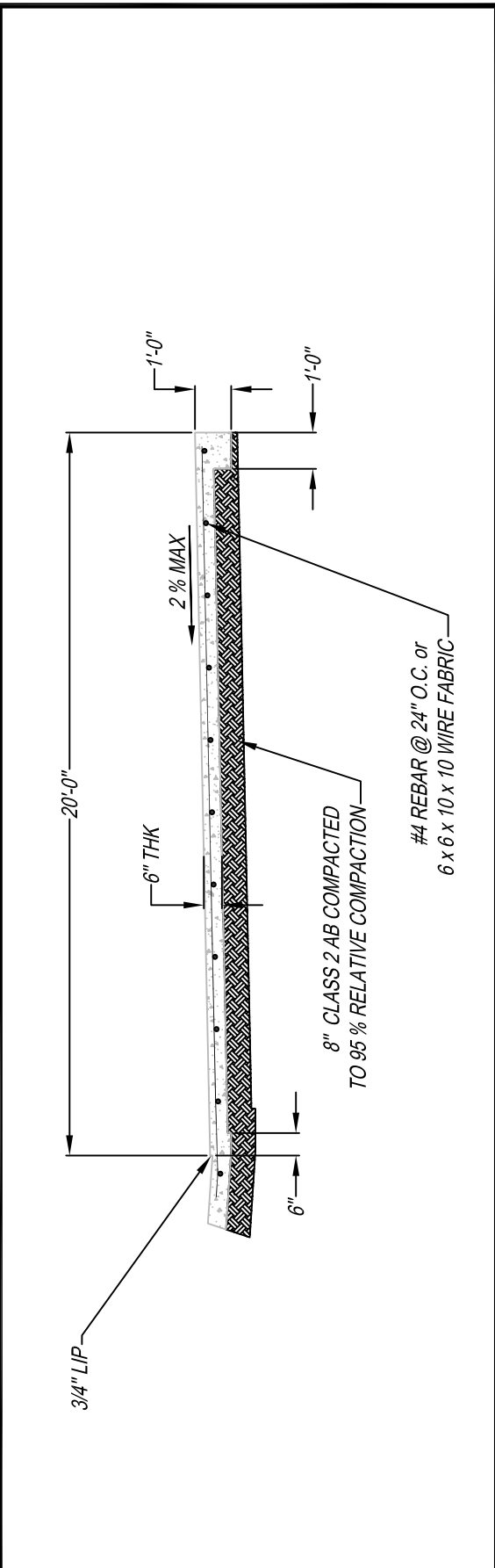
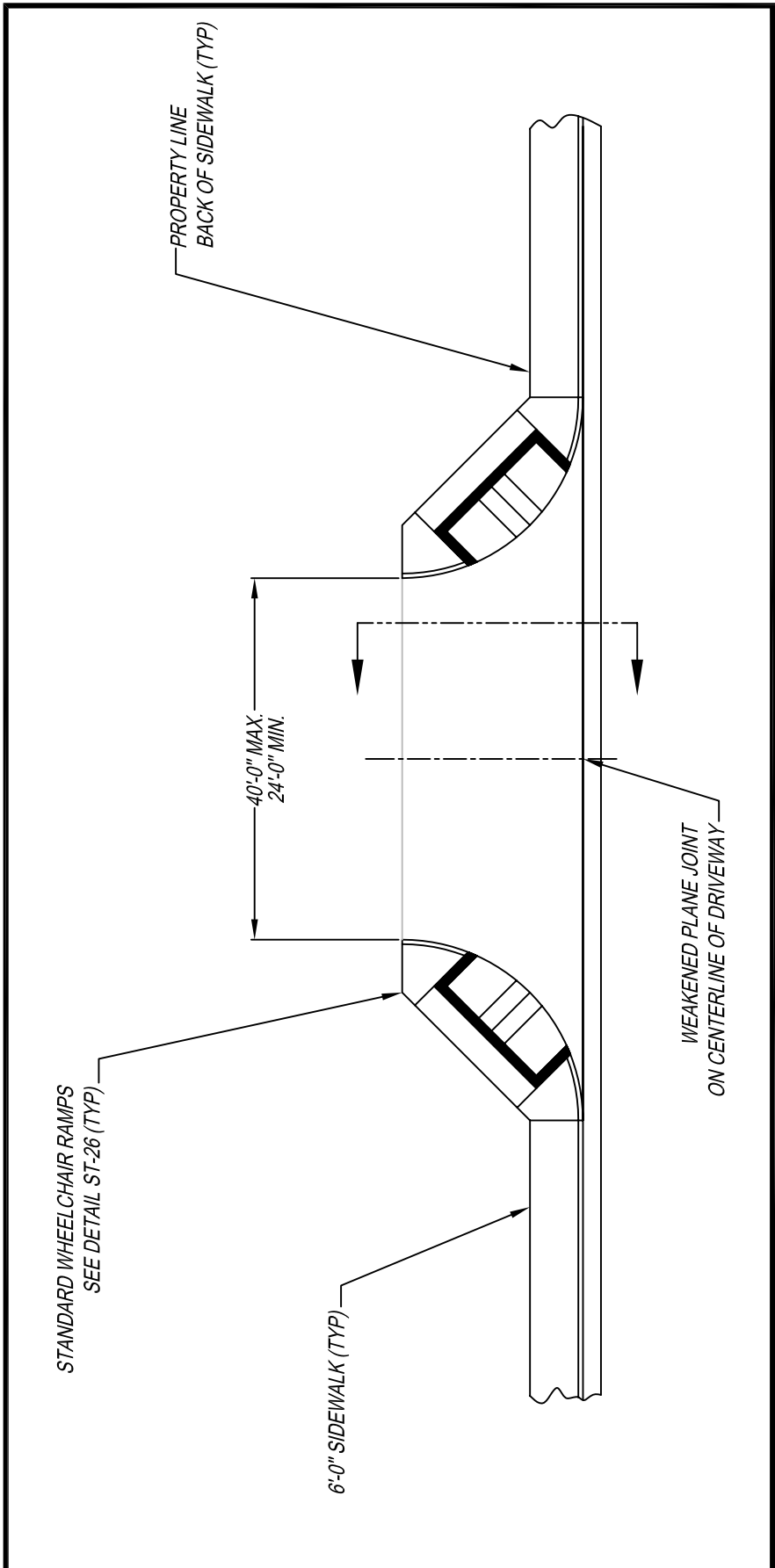

NO.	REVISED	BY
DRAWN BY: MCP		
CHECKED BY: MJM		
V:\125_City of Ripon Standards   Standard Specifications   Drawings   Streets   st-24c.dwg		

**Type 1 Commercial  
Driveway with Attached  
Sidewalk**

**CITY OF RIPON**

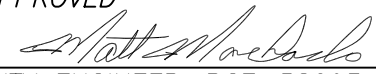
APPROVED  
  
 CITY ENGINEER RCE-58093  
 DATE: 12-4-2001  
 STANDARD NO. **ST-24c**

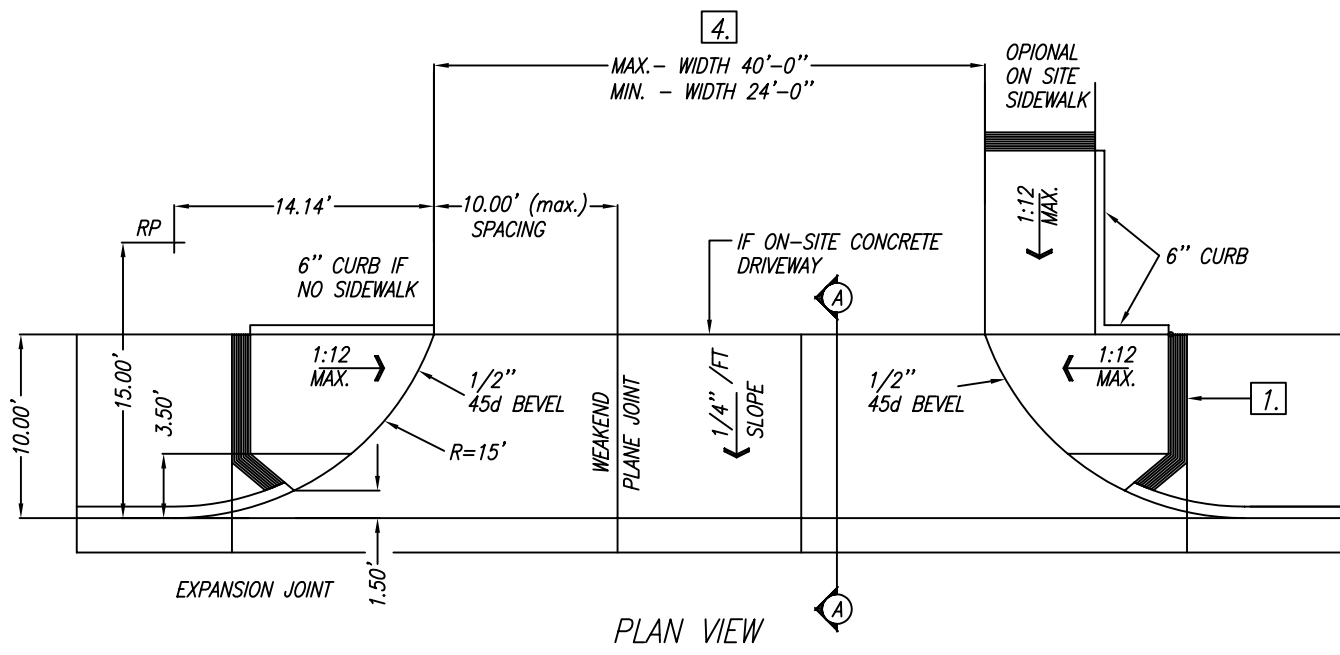

PLAN VIEW

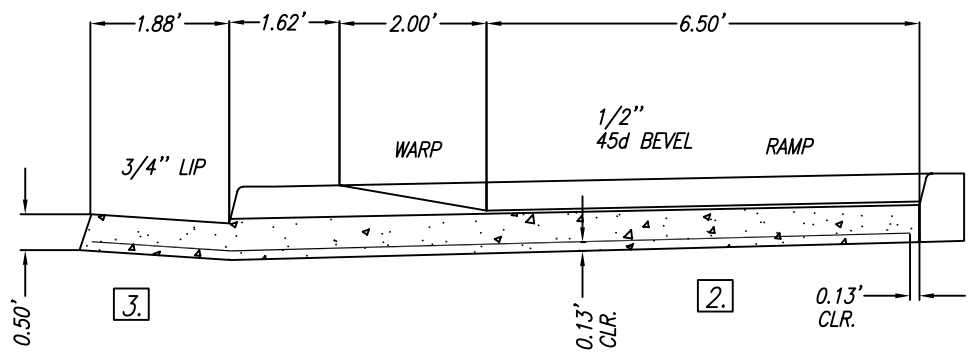

SECTION A - A

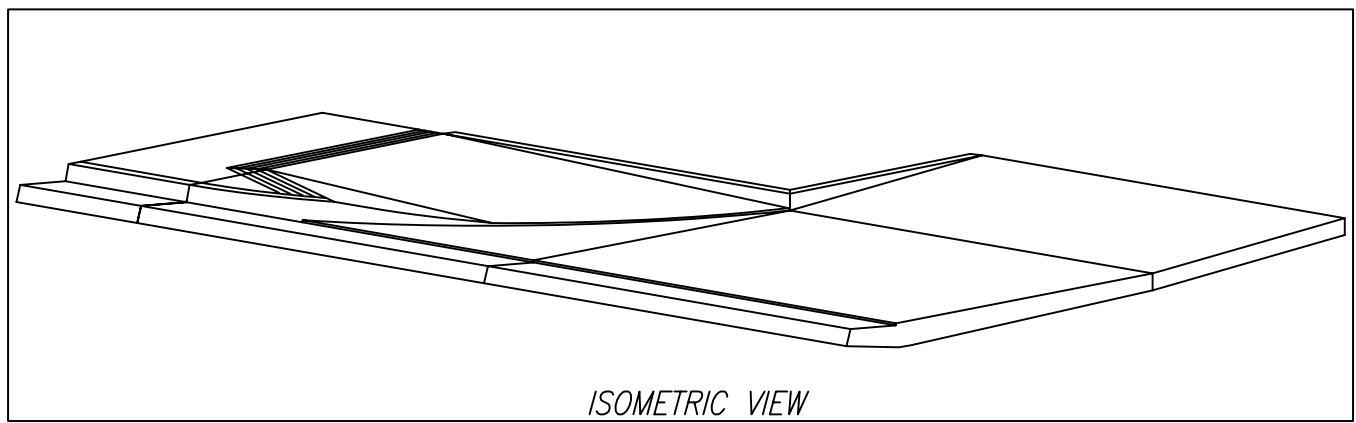

ISOMETRIC VIEW

- 1. 12" GROOVED BORDER
- 2. #4 BARS @ 18" O.C. EACH WAY. THE ENTIRE WIDTH OF DRIVEWAY AND RAMP
- 3. GUTTER PAN DIMENSIONS PER STANDARDS.
- 4. WIDTH GREATER THAN 40 FEET SUBJECT TO AGENCY TO AGENCY APPROVAL.

NO.	REVISED	BY	<b>Type 2 Commercial Driveway with Attached Sidewalk</b>	APPROVED	<b>CITY OF RIPON</b>	DATE: 2-2-99
				 CITY ENGINEER RCE-28191		
DRAWN BY: MCP				STANDARD NO. <b>ST-24d</b>		
CHECKED BY: DJR						
V:\25_City of Ripon Standards\Standard Specifications\Drawings\Streets\st-24d.dwg						

*THIS PAGE  
INTENTIONALLY LEFT BLANK*

<i>NO.</i>	<i>REVISED</i>	<i>BY</i>		<i>APPROVED</i>
				<i>CITY ENGINEER RCE-28191</i>
				<i>DATE:</i>
<i>DRAWN BY:</i>			<b><i>CITY OF RIPON</i></b>	<i>STANDARD NO. ST-25</i>
<i>CHECKED BY:</i>				
<small>V:\25_City of Ripon Standards\Standard Specifications\Drawings\Streets\st-25.dwg</small>				

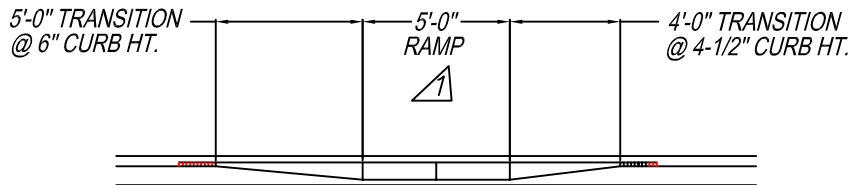
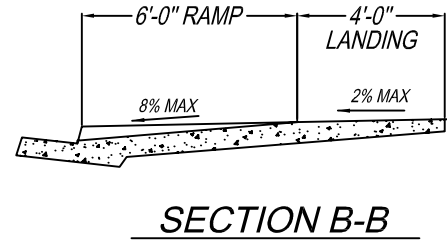
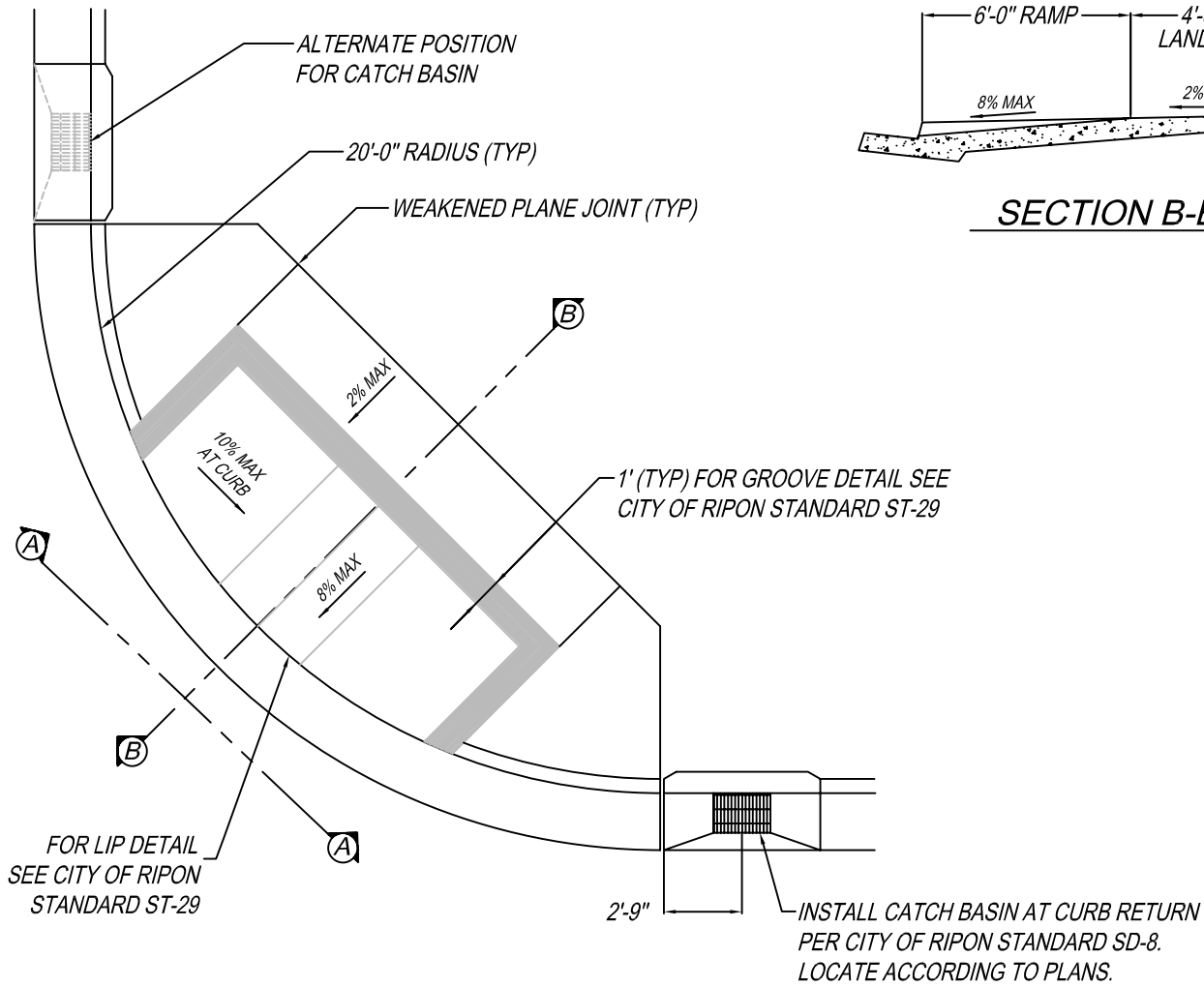

**NOTES:**

1. FINE HAIR BROOM FINISH ON ENTIRE WHEELCHAIR RAMP.
2. CONSTRUCTION SHALL BE IN ACCORDANCE WITH THE APPLICABLE SECTIONS OF THE CURRENT CITY OF RIPON SPECIFICATIONS.
3. MATERIAL UNDER ENTIRE WHEELCHAIR RAMP SHALL BE COMPACTED TO 95% RELATIVE COMPACTION FOR A DEPTH OF 8".
4. RAMP SLOPE SHALL BE 1:12 MAXIMUM (8% MAX).
5. TRANSITION SLOPE (WINGS) SHALL BE 1:10 MAXIMUM (10% MAX).
6. PROVIDE TRUNCATED DOME PER ST-29.

NO.	REVISED	BY	<b>Typical Wheelchair Ramp at Intersections</b>	APPROVED
	11/10/04	MCP		
				CITY ENGINEER RCE-28191
DRAWN BY:				DATE: 2-2-99
CHECKED BY: DJR			<b>CITY OF RIPON</b>	STANDARD NO. <b>ST-26</b>
V:\25_City of Ripon Standards\Standard Specifications\Drawings\Streets\st-26.dwg				

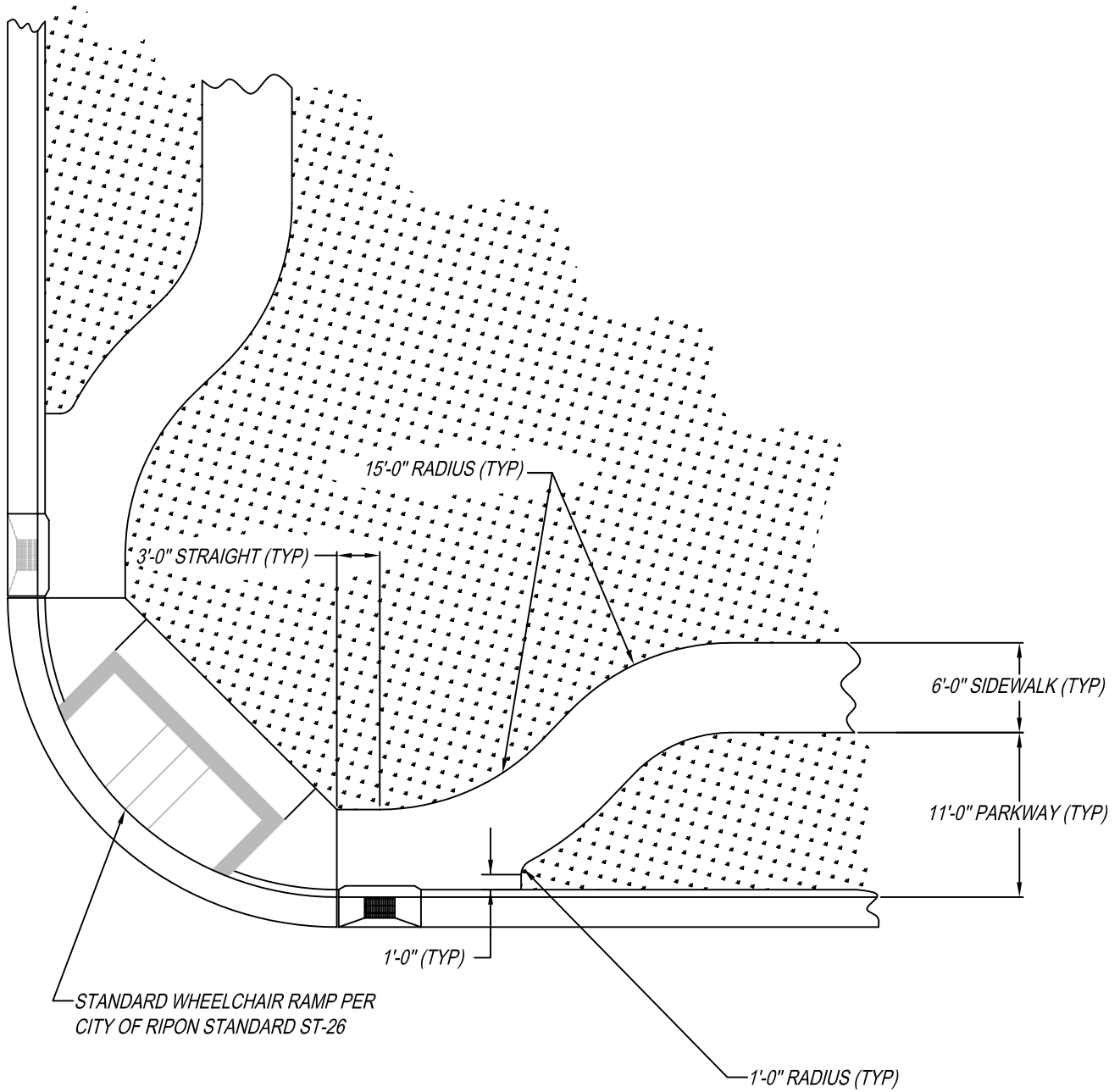

NO.	REVISED	BY	<b>Residential Wheelchair Ramp Detail for Detached Sidewalk</b>	APPROVED
				 CITY ENGINEER RCE-28191
				DATE: 2-2-99
				STANDARD NO. <b>ST-26a</b>
DRAWN BY: MCP CHECKED BY: DJR <small>V:\125_City of Ripon Standards\Standard Specifications\Drawings\Streets\st-26a.dwg</small>			<b>CITY OF RIPON</b>	



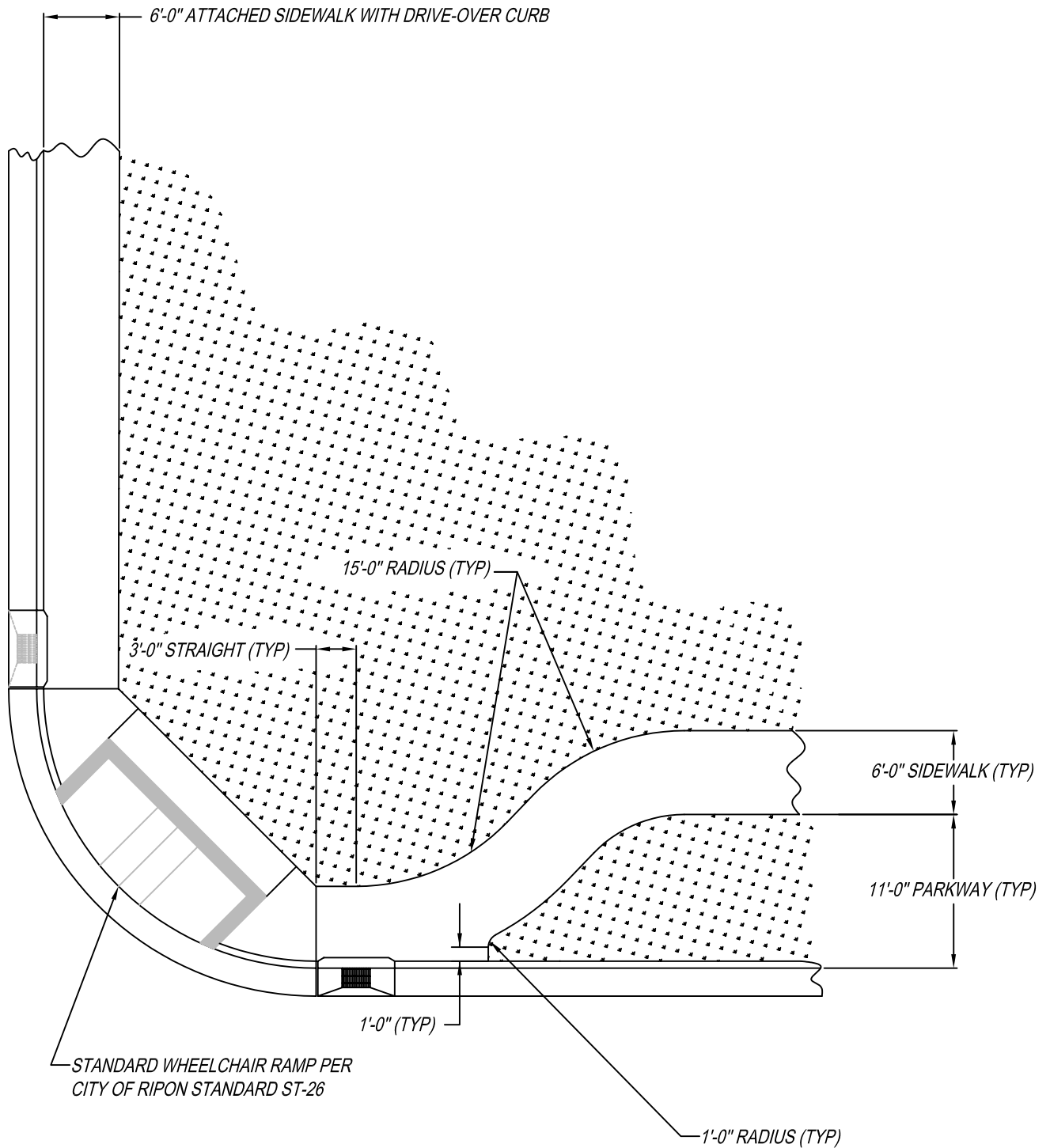

NO.	REVISED	BY	<b>Residential Wheelchair Ramp Detail for Detached to Attached Sidewalk</b>	APPROVED
				 CITY ENGINEER RCE-58093
DRAWN BY: KWZ				DATE: 12-4-2001
CHECKED BY: MJM			<b>CITY OF RIPON</b>	STANDARD NO. <b>ST-26b</b>
<small>V: 125_City of Ripon Standards   Standard Specifications   Drawings   Streets   st-26b.dwg</small>				

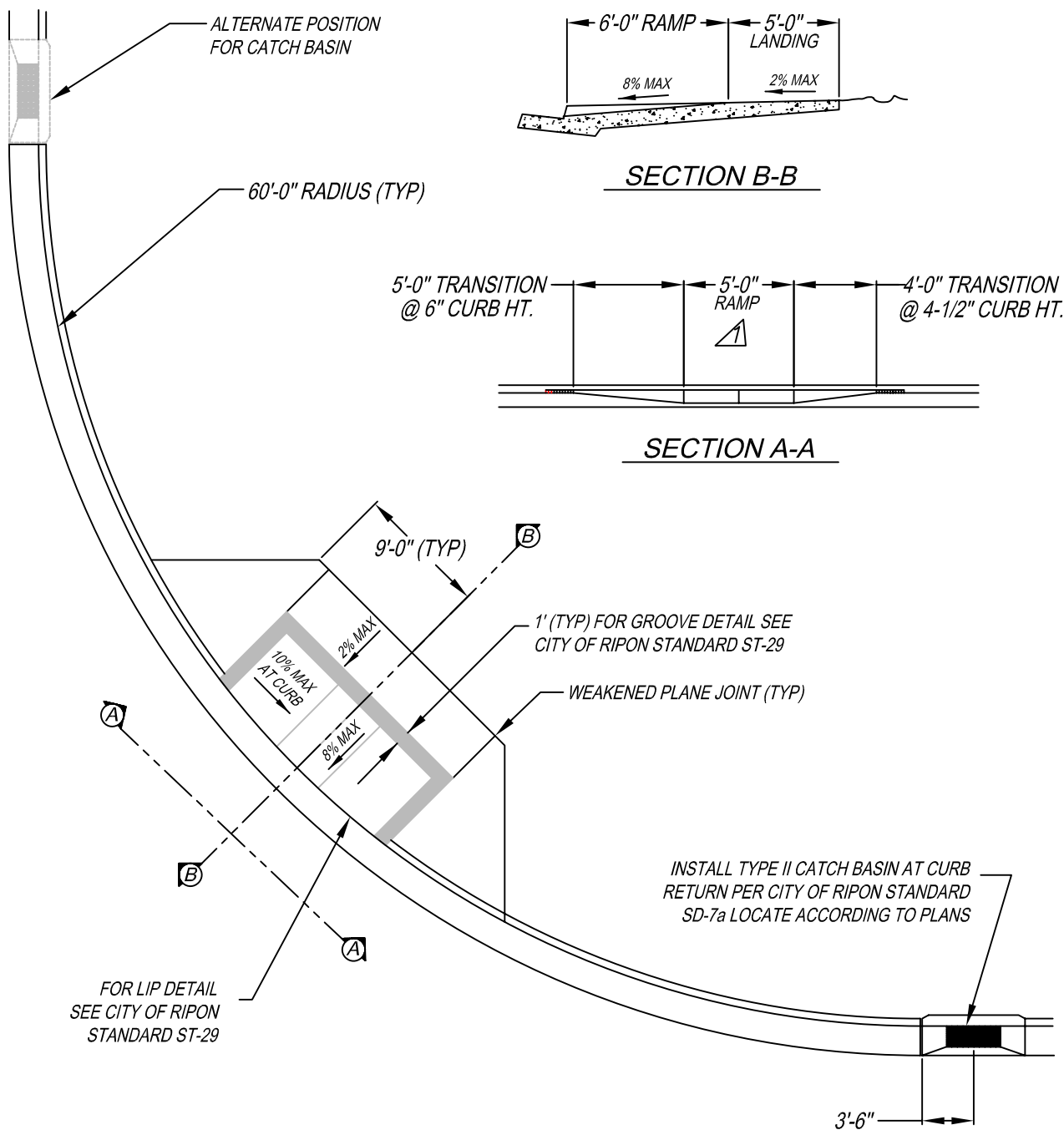

**NOTES:**

1. FINE HAIR BROOM FINISH ON ENTIRE WHEELCHAIR RAMP.
2. CONSTRUCTION SHALL BE IN ACCORDANCE WITH THE APPLICABLE SECTIONS OF THE CURRENT CITY OF RIPON SPECIFICATIONS.
3. MATERIAL UNDER ENTIRE WHEELCHAIR RAMP SHALL BE COMPACTED TO 95% RELATIVE COMPACTION FOR A DEPTH OF 8".
4. RAMP SLOPE SHALL BE 1:12 MAXIMUM (8% MAX).
5. TRANSITION SLOPE (WINGS) SHALL BE 1:10 MAXIMUM (10% MAX).
6. PROVIDE TRUNCATED DOME PER ST-29.

NO.	REVISED	BY	<b>Typical Wheelchair Ramp Detail for Commercial/ Industrial Applications</b>	APPROVED
△	11/10/04	MCP		 CITY ENGINEER RCE-58093
DRAWN BY: KWZ				DATE: 12-4-2001
CHECKED BY: MJM			<b>CITY OF RIPON</b>	STANDARD NO. <b>ST-27</b>
<small>V:\125_City of Ripon Standards\Standard Specifications\Drawings\Streets\st-27.dwg</small>				

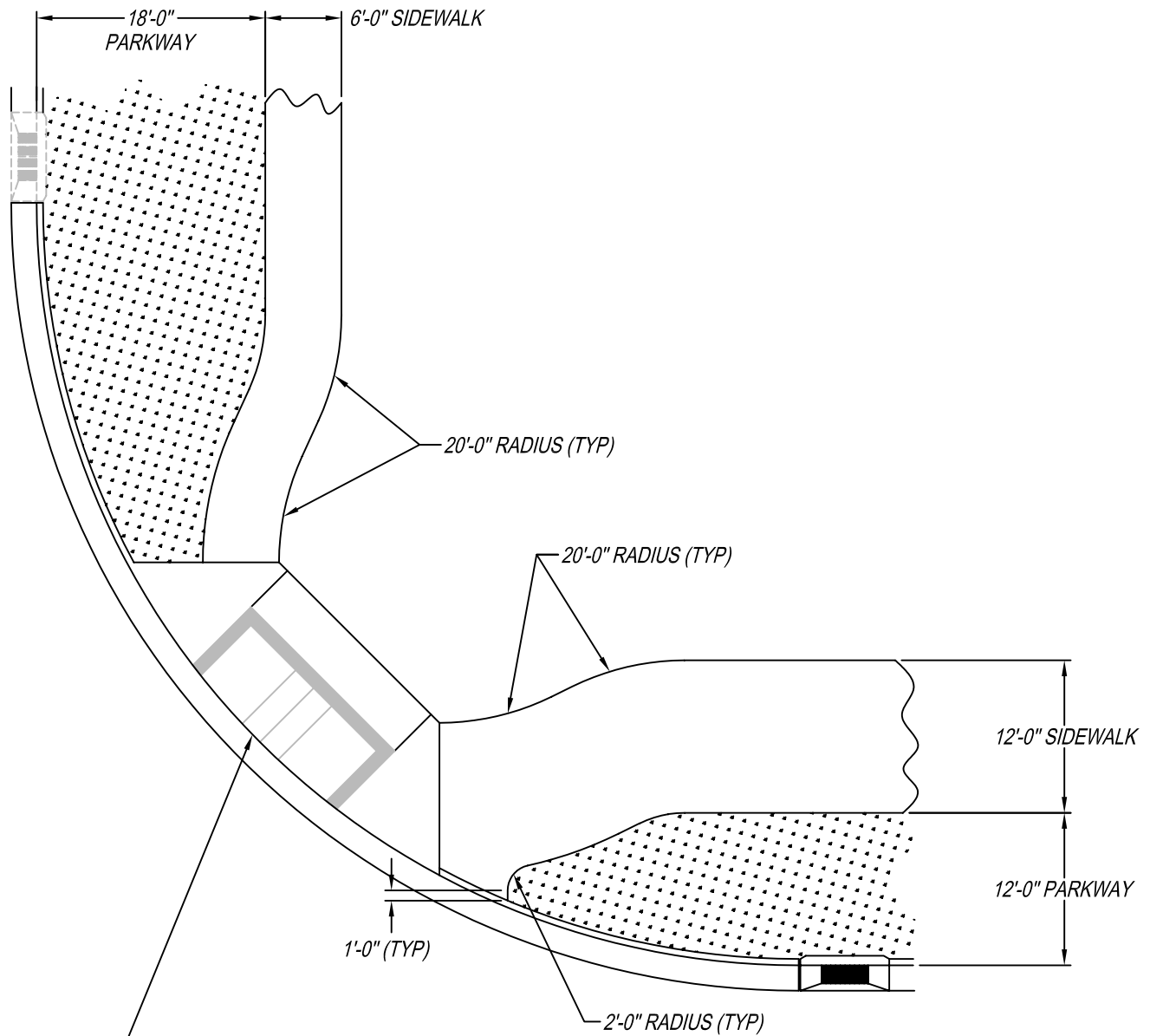

STANDARD COMMERCIAL/INDUSTRIAL  
WHEELCHAIR RAMP PER CITY OF  
RIPON STANDARD ST-27

NO.	REVISED	BY
DRAWN BY: KWZ		
CHECKED BY: MJM		
V: I 25_City of Ripon Standards   Standard Specifications   Drawings   Streets   st-27a.dwg		

**Commercial/Industrial  
Wheelchair Ramp Detail  
for 140' Right-of-Way**

**CITY OF RIPON**

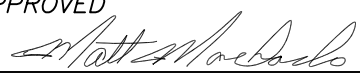
APPROVED  
  
 CITY ENGINEER RCE-58093  
 DATE: 12-4-2001  
 STANDARD NO. **ST-27a**

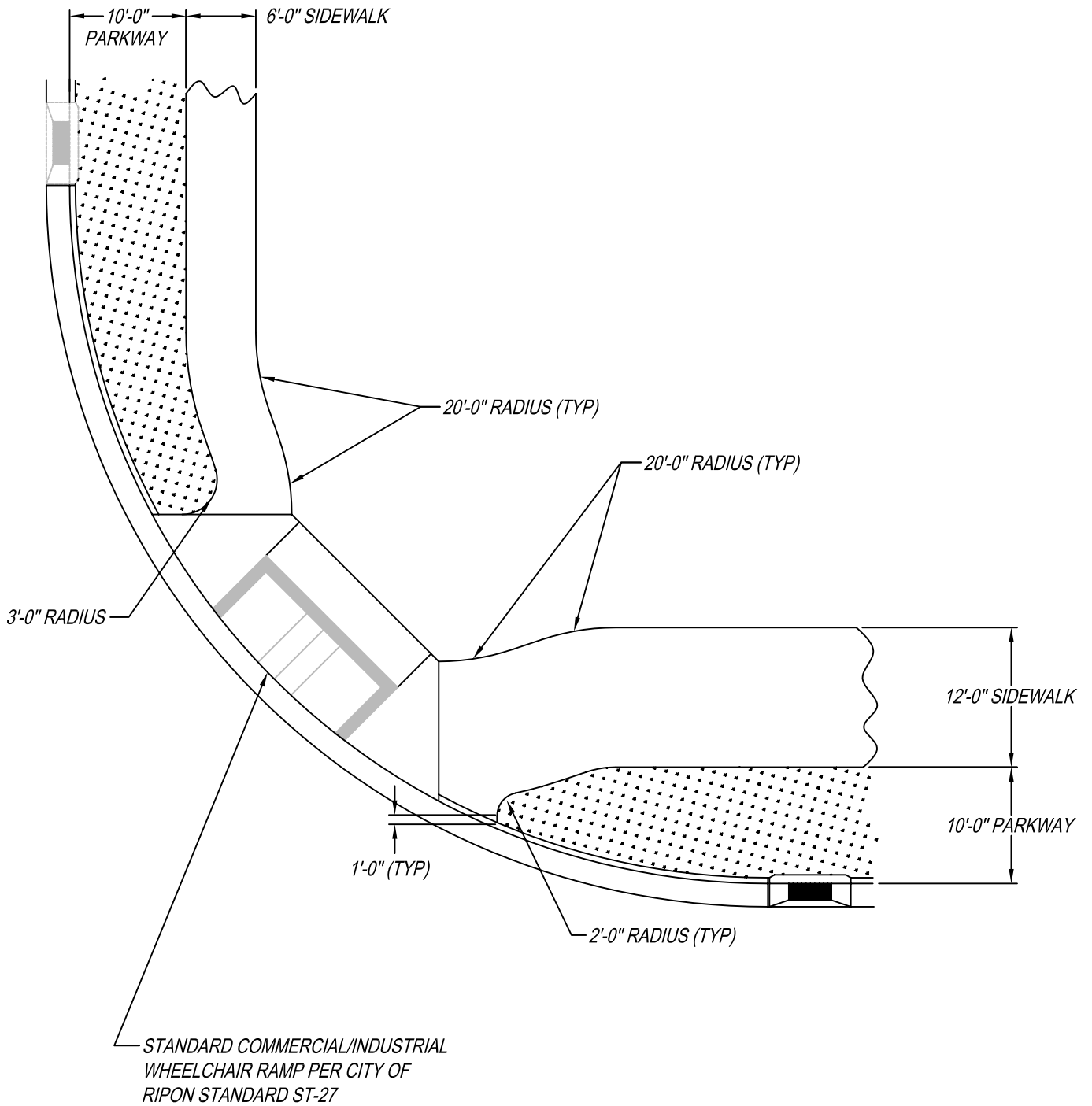

NO.	REVISED	BY	<p align="center"><b>Commercial/Industrial Wheelchair Ramp Detail for 102' Right-of-Way</b></p> <p align="center"><b>CITY OF RIPON</b></p>	APPROVED
				 CITY ENGINEER RCE-58093
				DATE: 12-4-2001
DRAWN BY: KWZ				STANDARD NO. <b>ST-27b</b>
CHECKED BY: MJM				
<small>V: 125_City of Ripon Standards   Standard Specifications   Drawings   Streets   st-27b.dwg</small>				

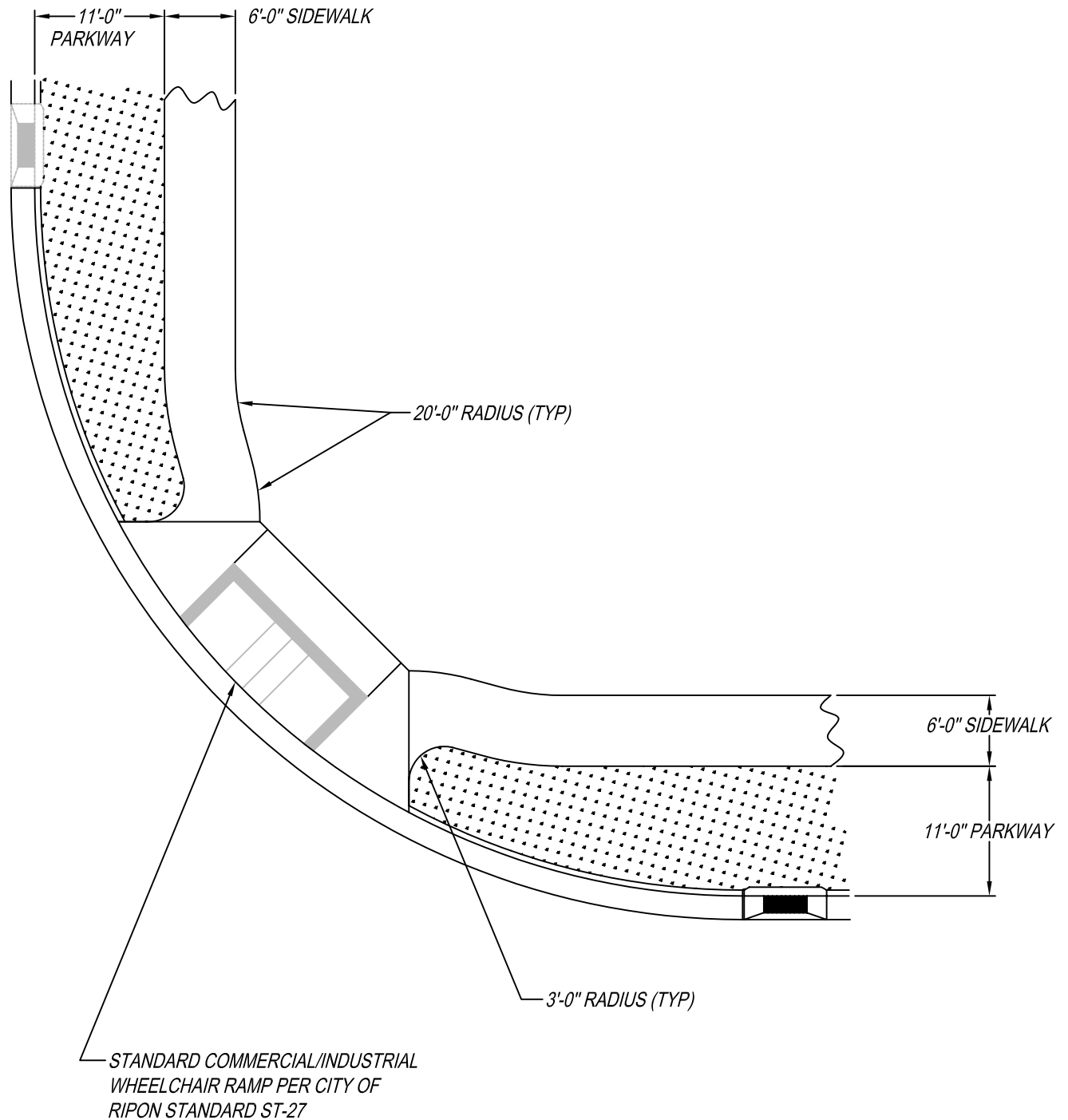

NO.	REVISED	BY	<p align="center"><b>Commercial/Industrial Wheelchair Ramp Detail for 82' and 74' Right-of-Way</b></p> <p align="center"><b>CITY OF RIPON</b></p>	APPROVED
				 CITY ENGINEER RCE-58093
DRAWN BY: KWZ				DATE: 12-4-2001
CHECKED BY: MJM			STANDARD NO. <b>ST-27c</b>	
<small>V: 125_City of Ripon Standards   Standard Specifications   Drawings   Streets   st-27c.dwg</small>				

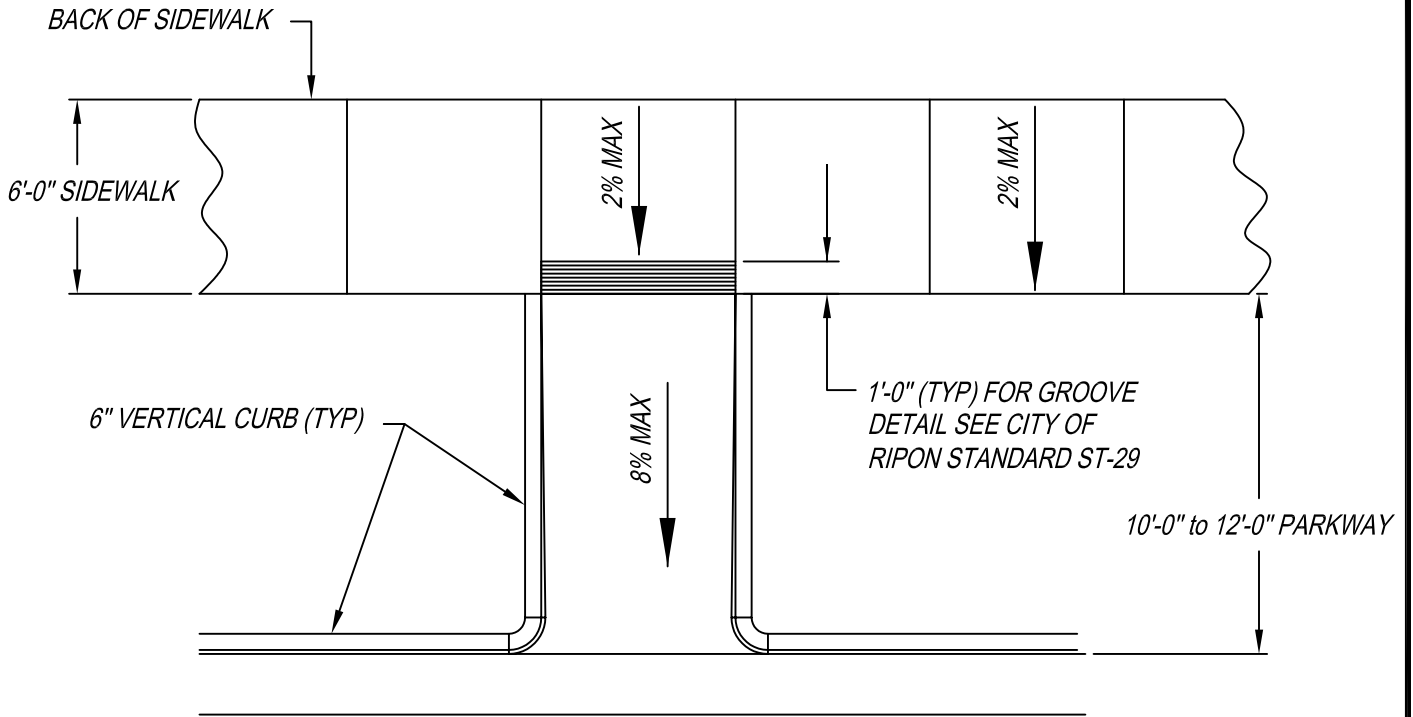

PLAN VIEW

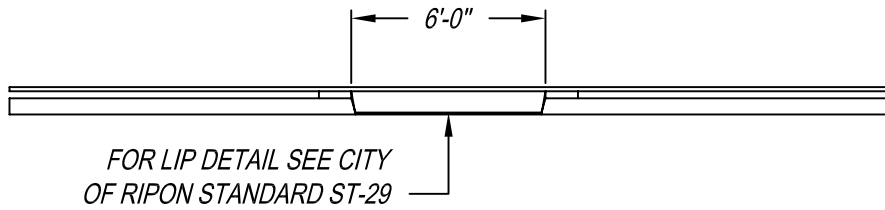

FRONT VIEW

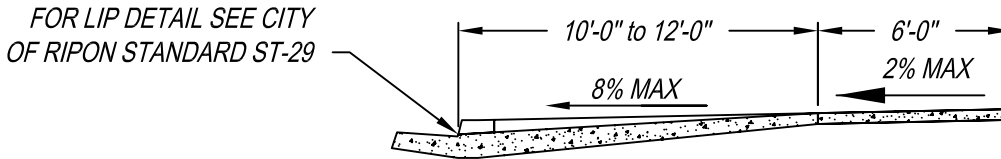

SECTION VIEW

NO.	REVISED	BY	<b>Typical Mid Block Wheelchair Ramp Detail with Detached Sidewalk</b>	APPROVED
				 CITY ENGINEER RCE-28191
				DATE: 2-2-99
DRAWN BY: MCP			<b>CITY OF RIPON</b>	STANDARD NO. <b>ST-28</b>
CHECKED BY: DJR				
<small>V:\125_City of Ripon Standards\Standard Specifications\Drawings\Streets\st-28.dwg</small>				

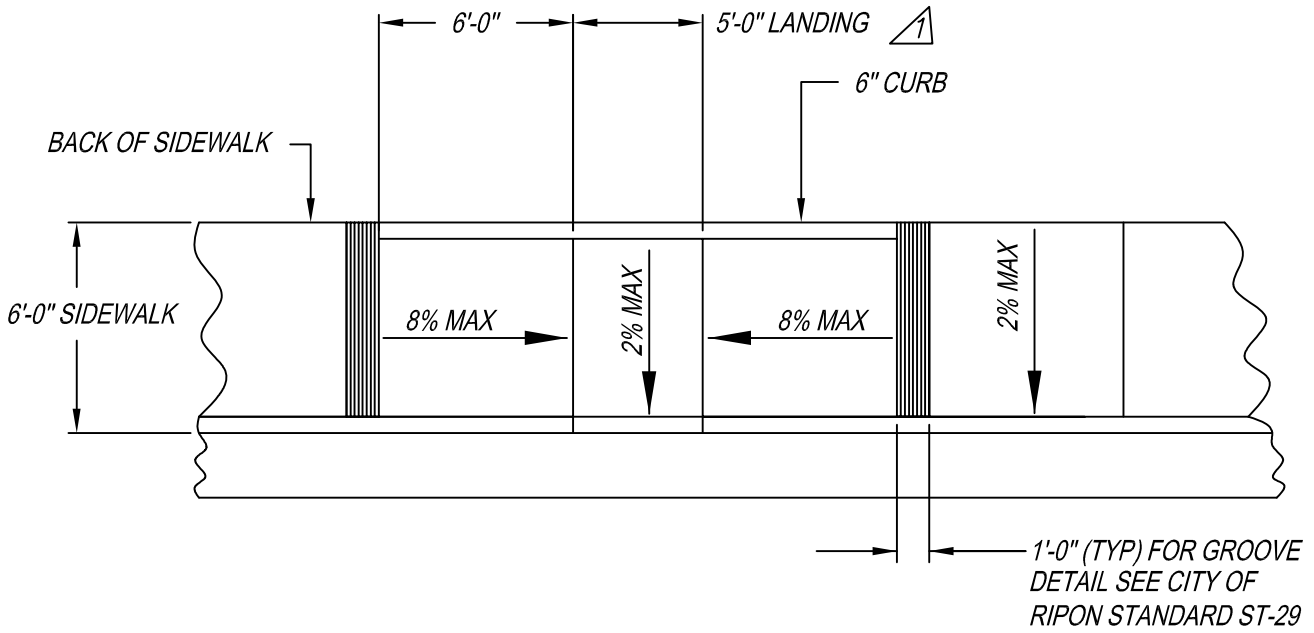

PLAN VIEW

NOTE: PROVIDE TRUNCATED DOME PER ST-29

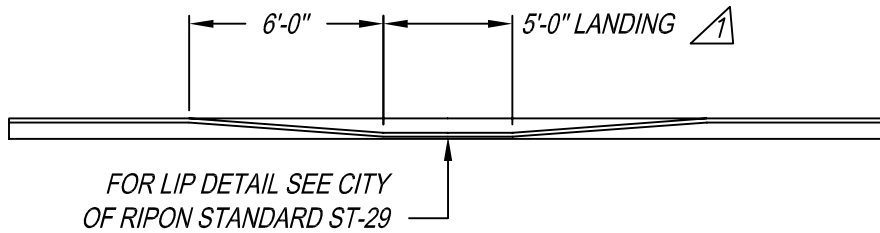

FRONT VIEW

NOTE: PROVIDE TRUNCATED DOME PER ST-29

NO.	REVISED	BY	<b>Typical Mid Block Wheelchair Ramp Detail with Attached Sidewalk</b>	APPROVED
	11/10/04	MCP		 CITY ENGINEER RCE-28191
DRAWN BY: MCP			<b>CITY OF RIPON</b>	DATE: 2-2-99
CHECKED BY: DJR				STANDARD NO. <b>ST-28a</b>
<small>V:\125_City of Ripon Standards\Standard Specifications\Drawings\Streets\st-28a.dwg</small>				

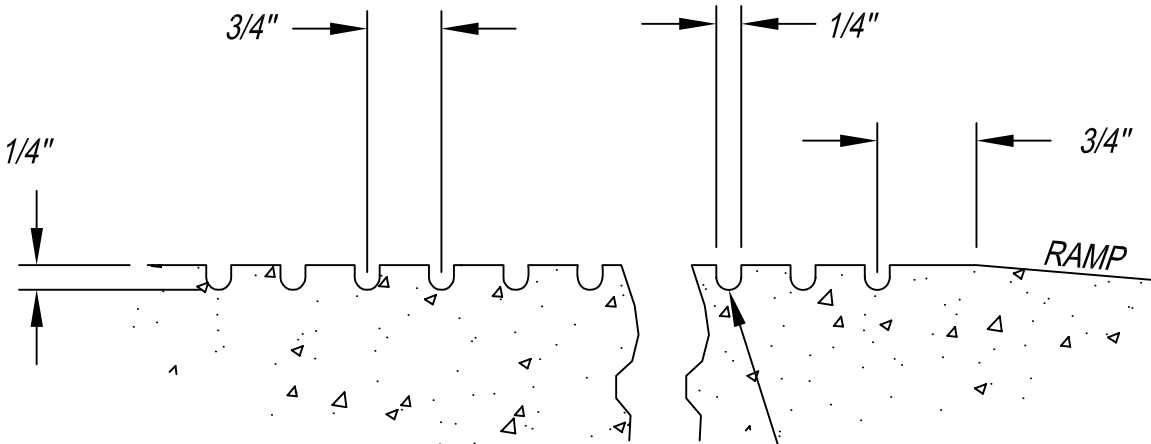
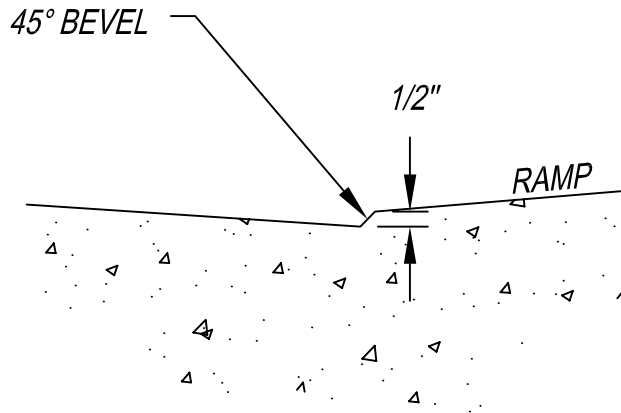

(1.66) CENTER TO CENTER SPACING

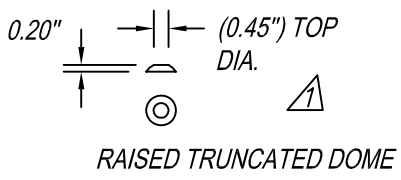
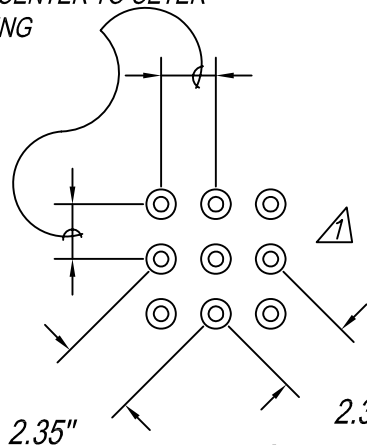

RAISED TRUNCATED DOME PATTERN (IN-LINE) DETECTABLE WARNING SURFACE

1/8" RADIUS (TYP)

NO.	REVISED	BY
△	11/10/04	MCP
DRAWN BY: MCP		
CHECKED BY: DJR		
V:\125_City of Ripon Standards\Standard Specifications\Drawings\Streets\st-29.dwg		

**Wheelchair Ramp  
Groove and Lip Detail and  
RAISED TRUNCATED DOME**

**CITY OF RIPON**

APPROVED

CITY ENGINEER RCE-28191
DATE: 2-2-99
STANDARD NO. <b>ST-29</b>



1'-0" WIDE GROOVE STRIP  
AND 1/2" BEVEL PER  
CITY STD. ST-29 (TYP)

BRICK PAVERS INSTALLED PER  
MANUFACTURERS RECOMMENDATIONS  
SEE NOTE #2

PAVERS TO BE FLUSH WITH  
GUTTER LIP AT RETURN (TYP)

SOLDIER COURSE

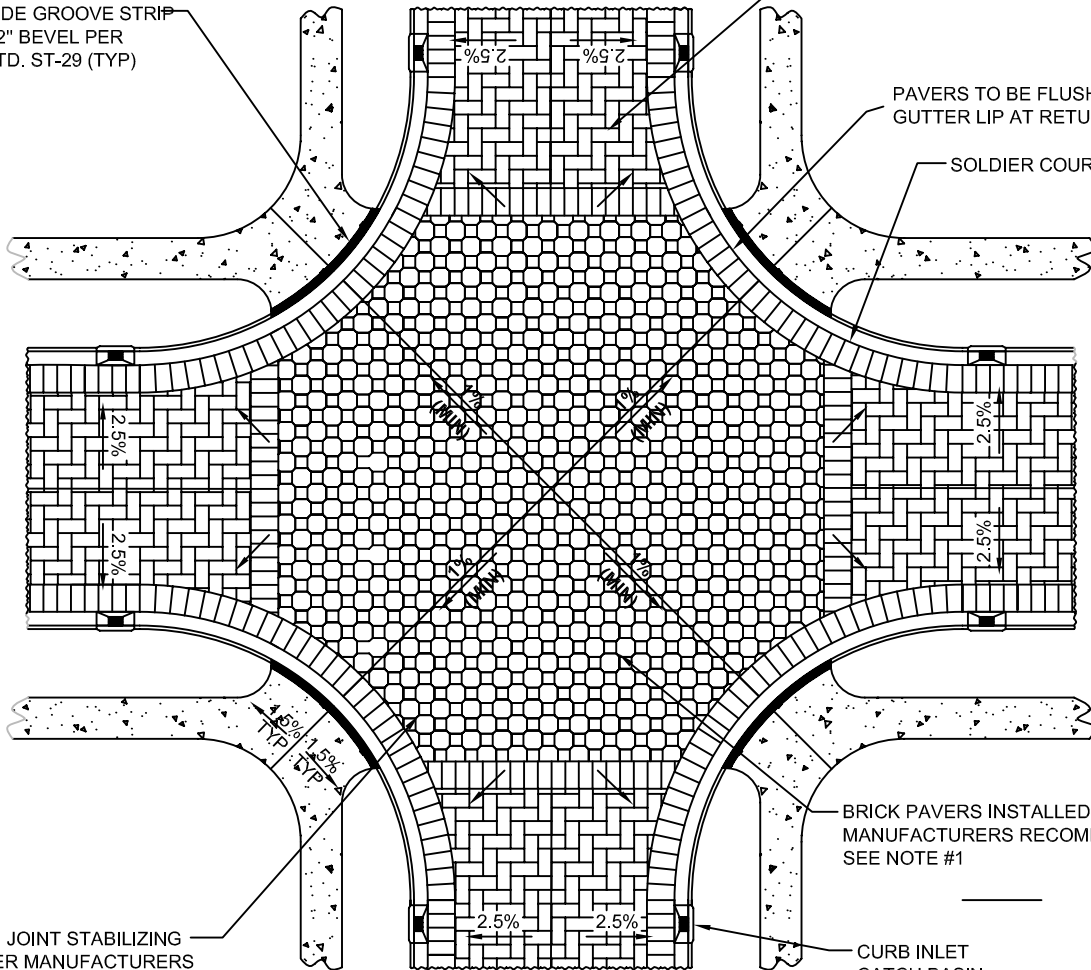

SEAL WITH JOINT STABILIZING  
SEALER PER MANUFACTURERS  
RECOMMENDATIONS

BRICK PAVERS INSTALLED PER  
MANUFACTURERS RECOMMENDATIONS  
SEE NOTE #1

CURB INLET  
CATCH BASIN  
(TYP)

SEE STANDARD NO. ST-30A  
FOR RAISED INTERSECTION  
SECTION VIEW

**NOTES:**

1. INTERIOR BRICK PAVERS:  
MANUFACTURER: BASALITE (OR APPROVED EQUAL)  
SIZE: 80 mm, 5.5" INTERLOCKING PAVERS  
STYLE: SPECTRUM  
COLOR: MENDOCINO
2. EXTERIOR BORDER PAVERS:  
MANUFACTURER: BASALITE (OR APPROVED EQUAL)  
SIZE: 80 mm, 3.15" BRICK PAVERS  
STYLE: 90 DEGREE HERRINGBONE  
COLOR: CHARCOAL TAN

NO.	REVISED	BY
1	11-28-05	ASV
DRAWN BY: KWZ		
CHECKED BY:		
V:\25_City of Ripon Standards\Standard Specifications\Drawings\Streets\st-30.dwg		

**Raised Paver Intersection  
Plan View Detail**

**CITY OF RIPON**

APPROVED
<i>Matthew MacBride</i>
CITY ENGINEER 58093
DATE: 11-7-00
STANDARD NO. <b>ST-30</b>

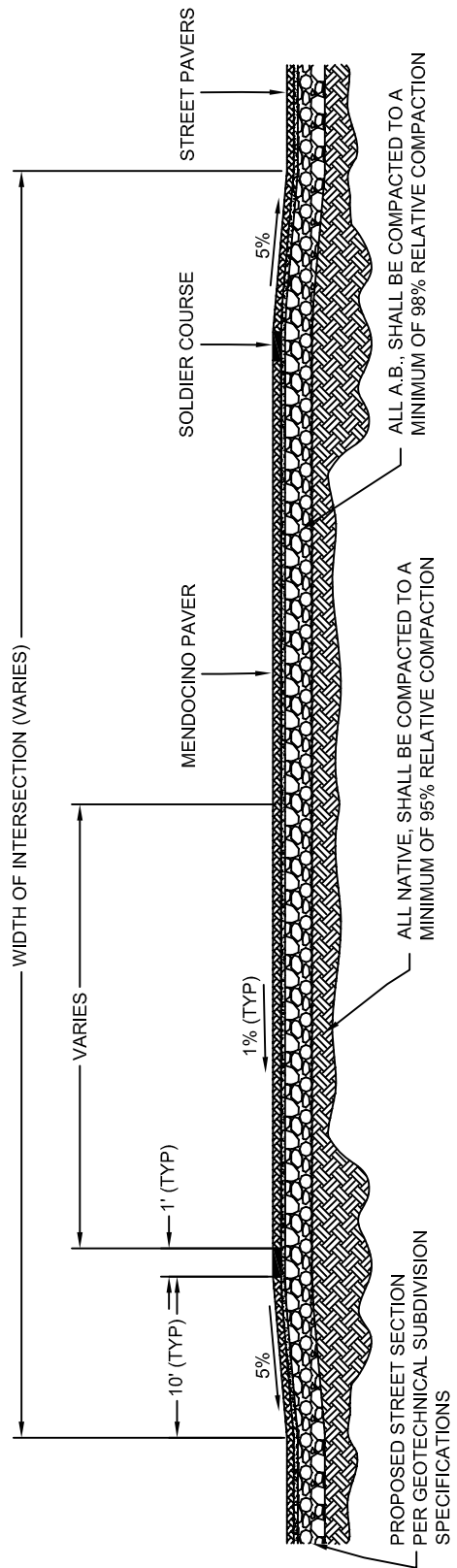

NOTE: ALL FOUR WAY INTERSECTIONS REQUIRE RAISED INTERSECTIONS

**RAISED INTERSECTION**

NOTE: SELECT OPTION WITH CITY APPROVAL

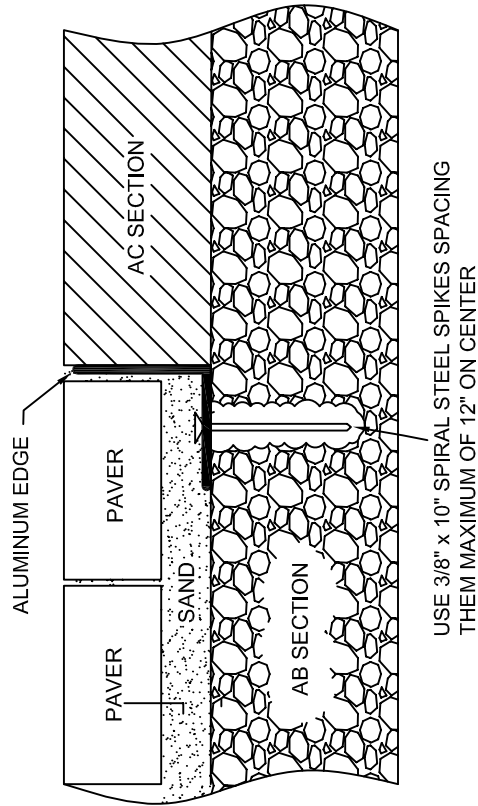

**ANCHORED ALUMINUM EDGE**

NOTE: SELECT OPTION WITH CITY APPROVAL

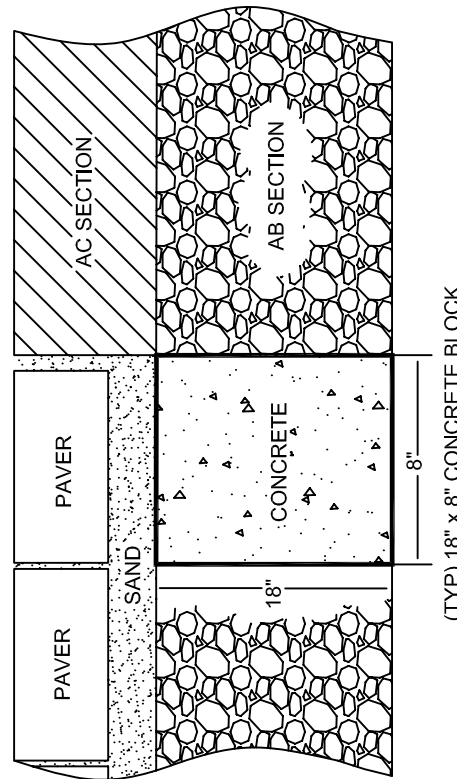

**SUBMERGED CONCRETE EDGE**

NO.	REVISED	BY
DRAWN BY: ASV		
CHECKED BY:		
V:\25_City of Ripon Standards\Standard Specifications\Drawings\Streets\st-30a.dwg		

**Raised Intersection | Paver Transition Section View Detail**

APPROVED  
  
 CITY ENGINEER 58093  
 DATE: 11-7-00

**CITY OF RIPON**

STANDARD NO. **ST-30a**

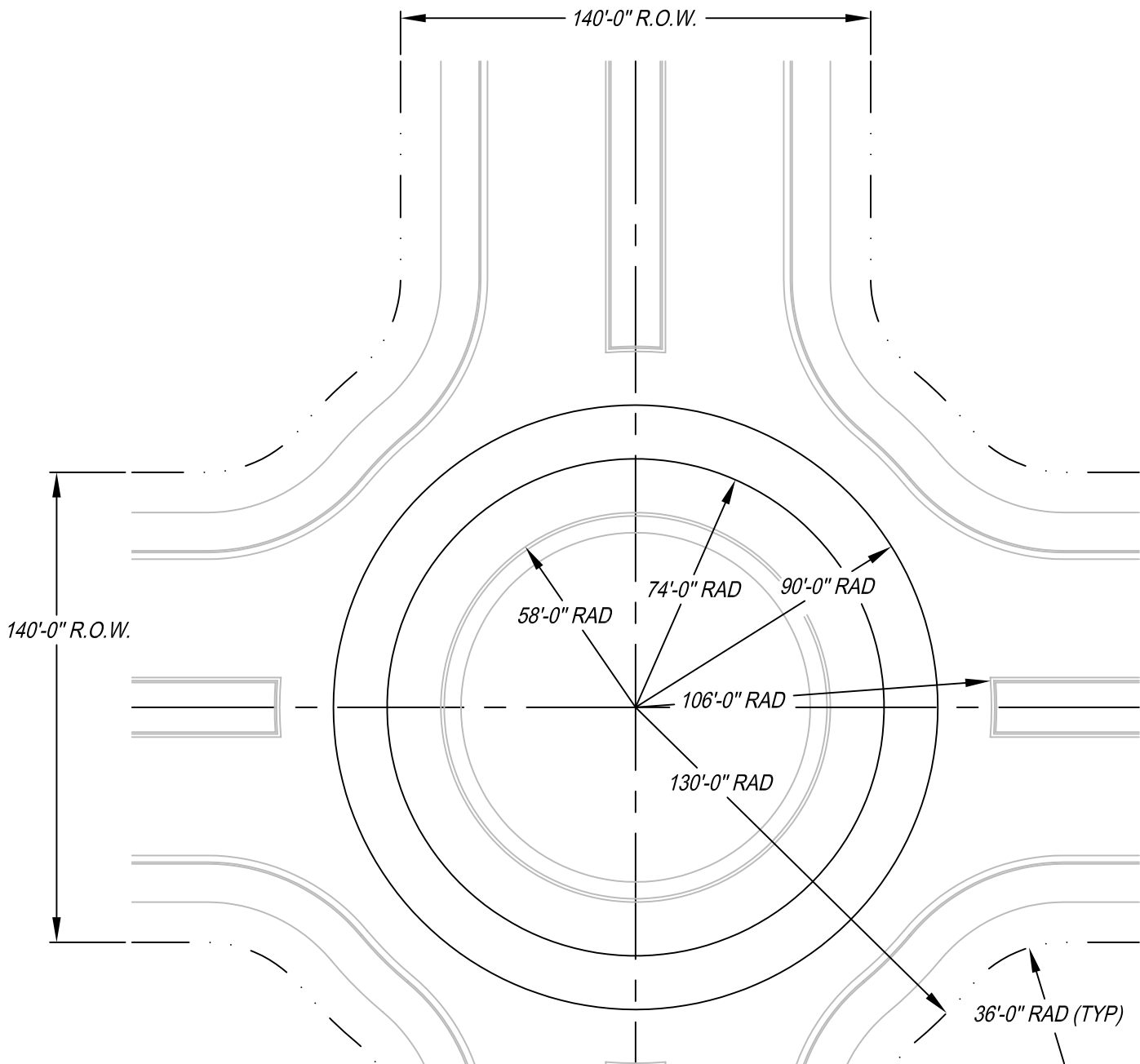

**NOTES:**

1. THIS DETAIL TO BE USED FOR LAYOUT PURPOSES ONLY.
2. STRIPPING & CONSTRUCTION DRAWINGS MUST BE APPROVED BY THE CITY ENGINEER.

NO.	REVISED	BY
▲	1-2003	MJM
DRAWN BY:		
CHECKED BY:		
V:125_City of Ripon Standards   Standard Specifications   Drawings   Streets   st-31.dwg		

**140' Right-of-Way  
Roundabout  
Geometrics**

**CITY OF RIPON**

APPROVED
<i>Matt Macbards</i>
CITY ENGINEER RCE-58093
DATE:
STANDARD NO. <b>ST-31</b>

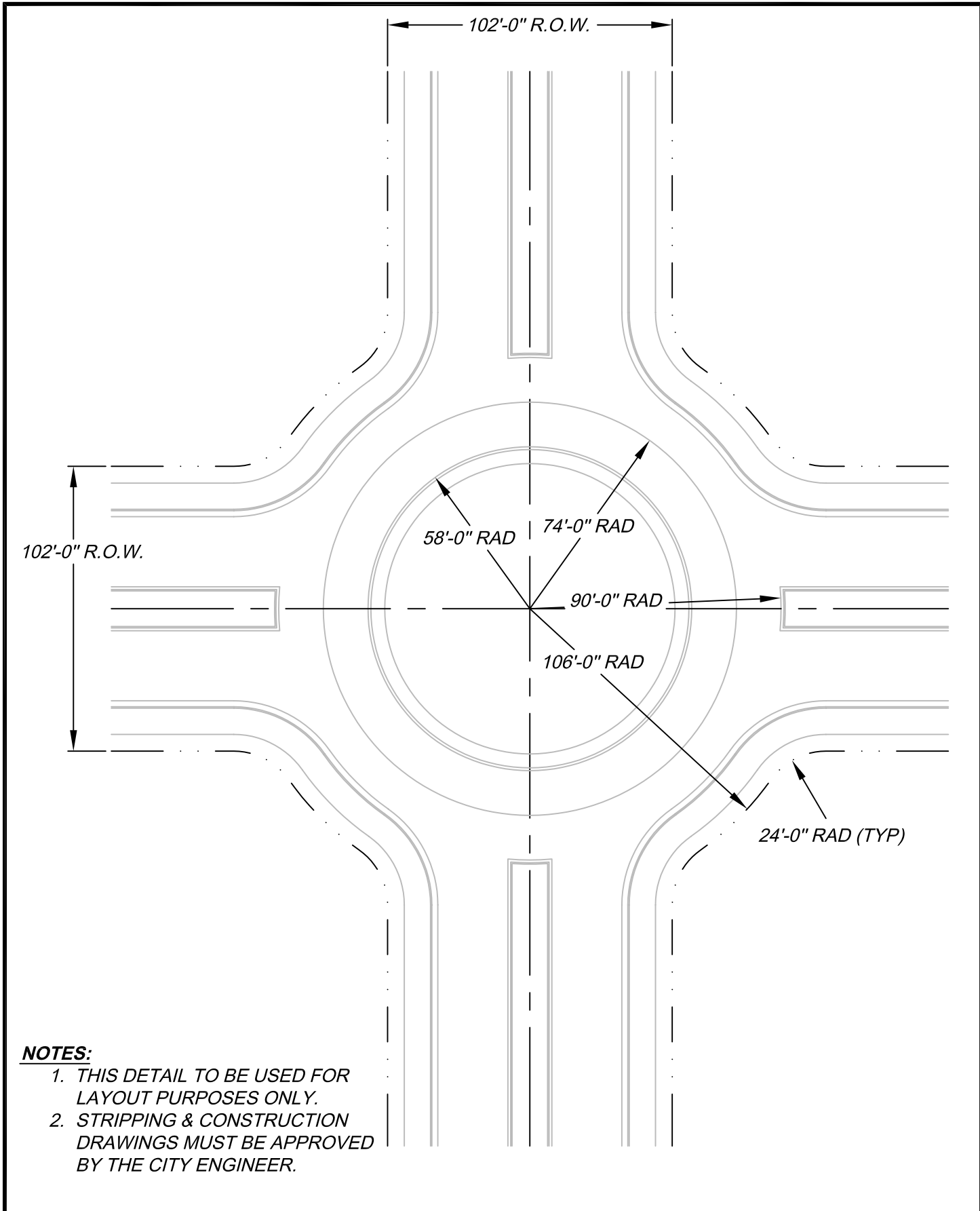

**NOTES:**

1. THIS DETAIL TO BE USED FOR LAYOUT PURPOSES ONLY.
2. STRIPPING & CONSTRUCTION DRAWINGS MUST BE APPROVED BY THE CITY ENGINEER.

NO.	REVISED	BY	<b>102' Right-of-Way Roundabout Geometrics</b>	APPROVED
△	1-2003	MJM		<i>Matt MacBride</i> CITY ENGINEER RCE-58093
DRAWN BY:			<b>CITY OF RIPON</b>	DATE:
CHECKED BY:				STANDARD NO. <b>ST-32</b>
V:\125_City of Ripon Standards \Standard Specifications \Drawings \Streets \st-32.dwg				

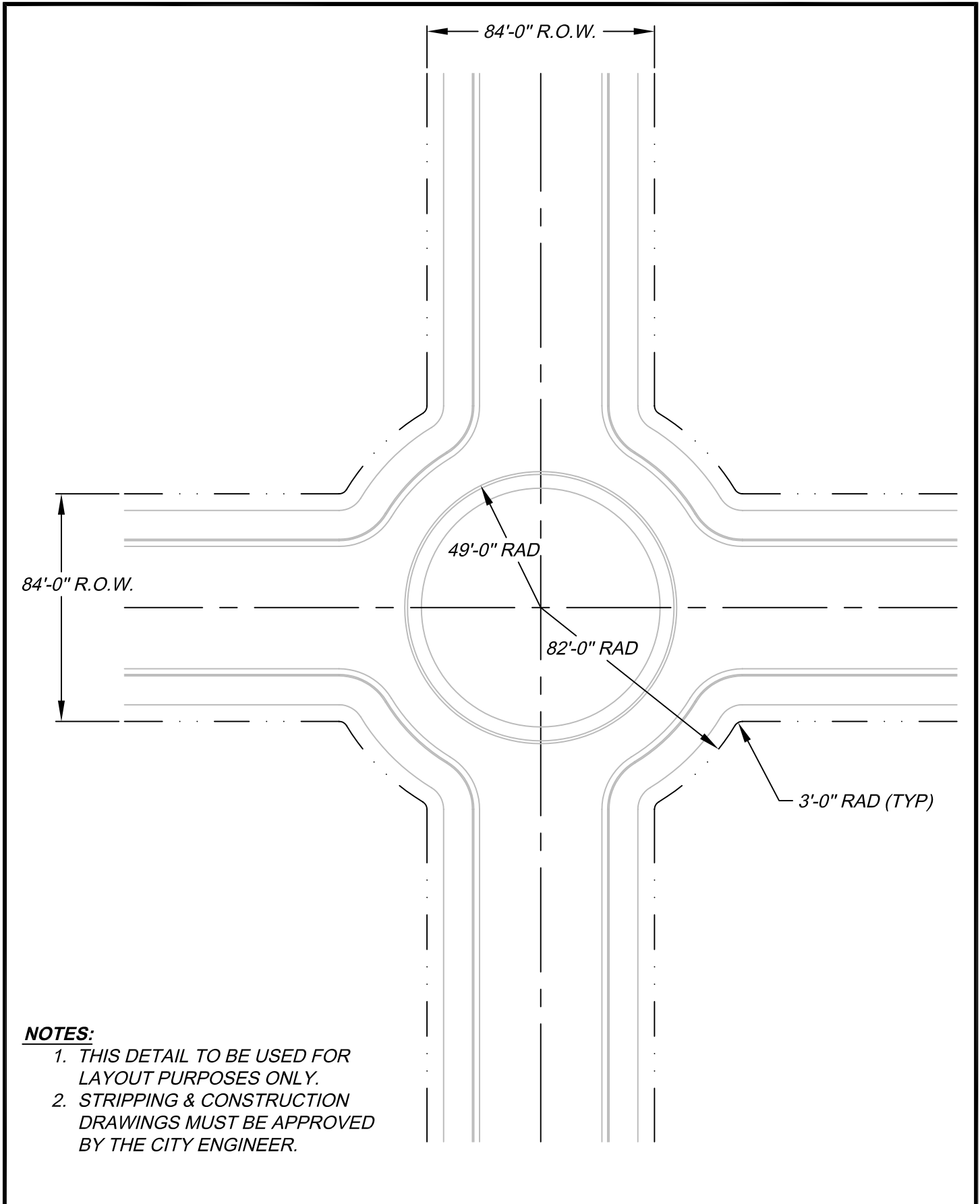

**NOTES:**

1. THIS DETAIL TO BE USED FOR LAYOUT PURPOSES ONLY.
2. STRIPPING & CONSTRUCTION DRAWINGS MUST BE APPROVED BY THE CITY ENGINEER.

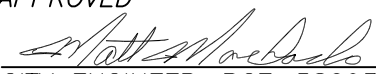
NO.	REVISED	BY	<b>84' Right-of-Way Roundabout Geometrics</b>	APPROVED
△	1-2003	MJM		 CITY ENGINEER RCE-58093
DRAWN BY:			<b>CITY OF RIPON</b>	DATE:
CHECKED BY:				STANDARD NO. <b>ST-33</b>
<small>V:\125_City of Ripon Standards \Standard Specifications \Drawings \Streets \st-33.dwg</small>				

# NOTES:

## 1. Water Service Pipe / Tube:

- A. For 1" water services, use ultra high molecular weight (UHMW), high density polyethylene (HDPE) pipe, ASTM D2329 / PE 3408, as manufactured by Drisco Pipe, Westflex, or approved equal, rated at 160 psi, SDR - 9, in iron pipe size (ips).
- B. For 1-1/2" and 2" water services, use UHMW, HDPE tube ASTM D-2737 / PE 3408, as manufactured by Drisco Pipe, Westflex, or approved equal, rated at 200 psi, SDR - 9, in copper tube size (cts).

## 2. Corporation Stops:

- A. 1" HDPE pipe - use James Jones J3402, Ford F1101, or approved equal.
- B. 1-1/2" or 2" HDPE tube - use James Jones J1937, Ford FB1100, or approved equal.
- C. All fittings shall have AWWA-CC threaded inlets.
- D. All HDPE pipe and tube compression connections shall use a manufacturer's recommended stainless steel inserts.

## 3. Ells:

- A. For 1" HDPE pipe, use James Jones J2611, Ford L66-44, or approved equal.
- B. For 1-1/2" or 2" HDPE tube, use James Jones J26211, Ford L44-66 for 1-1/2" tube, Ford L44-77 for 2" tube, or approved equal.
- C. All HDPE pipe and tube compression connections shall use manufacturer's recommended stainless steel inserts.

## 4. Angle Meter / Curb Stop:

- A. For 1" HDPE pipe, use James Jones J4202, Ford kv6j-444w, or approved equal.
- B. For 1-1/2" or 2" HDPE tube, use James Jones J4205, Ford FV43-666W for 1-1/2" tube, Ford FV43-777W for 2" tube, or approved equal.
- C. All angle meter / curb stops shall include lock wings.

NO.	REVISED	BY	<b>General Requirements for Water Services</b>	APPROVED
				 CITY ENGINEER RCE-28191
DRAWN BY: MATT				DATE: 2-2-99
CHECKED BY: DJR				STANDARD NO. <b>W-1</b>
V:\125_City of Ripon Standards\Standard Specifications\Drawings\Water\w-1.dwg			<b>CITY OF RIPON</b>	

# NOTES:

## 5. Service Saddles:

- A. The service saddle for all sizes of water service lines shall be a James Jones J996, Ford 90S, or approved equal, with double strapping, AWWA CC threaded outlet and buna N rubber seat gasket.

## 6. Meter Boxes:

- A. For 1" water services, use Brooks No. 37 or Christy No. B16 body. Lids shall be concrete with reading lid features or cast iron for traffic exposure such as a Brooks No. 37T or Christy B-16C, or approved equal.
- B. For 1-1/2" and 2" water services, use a Brooks No. 66 or Christy No. B36 body. Lids shall be concrete with a reading lid feature or for traffic exposure a steel cover such as a Christy B-36-61G or Brooks No. 66TR, or approved equal.
- C. Where H-20 traffic loading is expected, a special box and lid such as Christy B-1720 with 1/2" steel lid as approved by the City Engineer shall be used.

## 7. Meter Idler Pipe:

- A. For 1" water service, use a 10-3/4" long idler pipe, Ford No. 4 idler pipe or approved equal.
- B. For 1-1/2" water service, use a 13" long idler pipe, Ford No. 6 idler pipe or approved equal.
- C. For 2" water service, use a 17" long idler pipe, Ford No. 7 idler pipe, or approved equal.

NO.	REVISED	BY	<b>General Requirements for Water Services</b>	APPROVED	
				 CITY ENGINEER RCE-28191	
				DATE: 2-2-99	
				STANDARD NO. <b>W-2</b>	
DRAWN BY: MATT			<b>CITY OF RIPON</b>		
CHECKED BY: DJR					
V:\125_City of Ripon Standards\Standard Specifications\Drawings\Water\w-2.dwg					

1. *The City of Ripon Water Master Plan is in effect and any design deviation from this plan shall be submitted in writing to the City Engineer for approval.*
2. *Water line design and construction shall conform to California Administration Code Title 22, "California Water Works Standard" and the requirements of the California Health Department.*
3. *Water line sizing and routing, in new development not covered by the water master plan, shall be determined by the City Engineer.*
4. *Water lines in cul-de-sacs shall be of the following sizes:*
  - a. *4 inch minimum when serving residences that have fire protection from another line.*
  - b. *6 inch minimum when used in a looped system that also supplies fire protection.*
  - c. *8 inch minimum up to the fire hydrant tee on dead end lines.*
5. *Water lines shall have a minimum of 30 inches and a maximum of 36 inches of cover to finished grade.*
6. *Minimum separation requirements for water mains from sanitary sewer and storm drain lines shall be as follows:*
  - a. *The parallel horizontal separation between water mains and sanitary sewers and storm drains shall be at least ten feet.*
  - b. *Sanitary sewer and storm drain lines shall be constructed of ductile iron cement lined pipe for a distance of ten feet in each direction from the crossing of any water mains unless the water main is at least one (1) foot above the sanitary sewer or storm drain line.*
  - c. *At sanitary sewer or storm drain crossings, the water main shall be constructed so that the pipe joints of the water main will be located equal distances from the sewer or storm drain line.*
7. *Valve installation requirements shall be as followed:*
  - a. *Minimum of two (2) valves at tees.*
  - b. *Minimum of three (3) valves at crosses.*
  - c. *Transmission mains to residential areas shall have a maximum of 800 feet between valves.*
  - d. *Transmission mains to commercial areas shall have a maximum of 500 feet between valves.*
8. *Blow-offs or fire hydrants shall be installed at all dead end water mains.*
9. *Fire hydrant locations shall be approved by the City of Ripon and the Ripon Consolidated Fire District.*
10. *All water lines, valves, and other appurtenances shall conform to AWWA and th City of Ripon Standard Plans and Specifications.*
11. *Prior to construction, contractor shall make arrangements with the Public Works Department to shut off any City water valves.*
12. *Existing valves in water mains shall only be opened or closed by an authorized representative of City of Ripon.*
13. *All water meters will be provided and installed by the Developer and/or the Contractor.*
14. *All water services for residential lots shall be a minimum of one (1) inch in diameter.*
15. *A locating 'trace wire' is required on all non-metallic water service lines.*
16. *Backflow prevention devices may be required by the City Engineer. City Standards for backflow prevention are available in the public works department.*
17. *Connection of new mains to existing City mains will require 'Hot-Tap' connections, unless otherwise approved by the City Engineer. All 'Hot-Tapping' hardware shall be approved by the City Engineer.*

NO.	REVISED	BY	<b>Water Line Design Criteria</b>	APPROVED	
				 CITY ENGINEER RCE-28191	
DRAWN BY: MATT				DATE: 2-2-99	
CHECKED BY: DJR				STANDARD NO. <b>W-3</b>	
<small>V:\25_City of Ripon Standards\Standard Specifications\Drawings\Water\w-3.dwg</small>			<b>CITY OF RIPON</b>		



**A. BASIC SEPARATION STANDARDS**

The "California Waterworks Standards" set forth the minimum separation requirements for water mains and sanitary sewer and storm drain pipes (from this point on referred to as SS/SD lines). These standards, contained in section 64630, title 22, California Administrative Code, specify:

- 1.) parallel construction: the horizontal distance between pressure water mains and SS/SD lines shall be at least 10 feet.
- 2.) perpendicular construction (crossing): pressure water mains shall be at least one foot above SS/SD lines where these lines must cross.
- 3.) separation distances specified in 1 and 2 above, shall be measured from the nearest edges of the facilities.
- 4.) common trench: water mains and SS/SD lines must not be installed in the same trench.

When the water mains and SS/SD lines are not adequately separated, the potential for contamination of the water supply increases. Therefore, when adequate physical separation cannot be attained, an increase in the factor of safety should be provided by increasing the structural integrity of both the pipe materials and joints.

**B. EXCEPTIONS TO BASIC SEPARATION STANDARDS**

Local conditions, such as available space, limited slope, existing structures, etc. may create a situation where there is no alternative but to install water mains or SS/SD lines at a distance less than that required by the basic separation standards. In such cases, alternative construction criteria as specified in section D should be followed, subject to the special provisions in Section C.

Water mains and SS/SD of 24 inch in diameter or greater may create special hazards because of the large volumes of flow, therefore, installation of water mains and SS/SD lines 24 inches in diameter or larger should be reviewed and approved by the California Department of Health Services, Public Water Supply Branch, prior to construction.

**C. SPECIAL PROVISIONS**

- 1.) The basic separation standards are applicable under normal conditions for SS/SD collection lines and water distribution mains. More stringent requirements may be necessary if conditions such as high groundwater exist.
- 2.) SS/SD lines shall not be installed within 25 feet horizontally of a low head (5 psi or less pressure) water main.
- 3.) In the installation of water mains or sanitary sewer and/or storm drain lines, measures should be taken to prevent or minimize disturbances of the existing line. Disturbances of the supporting base of these lines could eventually result in failure of this existing pipeline.
- 4.) Special considerations shall be given to the selection of pipe materials if corrosive conditions are likely to exist. These conditions may be due to soil type and or the nature of the fluid conveyed in the conduit, such as a septic sewage which produces corrosive hydrogen sulfide.
- 5.) Sanitary Sewer and/or Storm Drain Force Mains:
  - a) Sanitary sewer and/or storm drain force mains shall not be installed within ten feet (horizontally) of a water main.
  - b) When a sanitary sewer and/or storm drain force main must cross a water line, the crossing should be as close as practical to the perpendicular. The sanitary sewer and/or storm drain force main should be at least one foot below the water line.

NO.	REVISED	BY	<p><b>Criteria for Separation of Water Mains from SS/SD Lines</b></p>	APPROVED	 CITY ENGINEER RCE-28191
				DATE: 2-2-99	
DRAWN BY: MATT				STANDARD NO. <b>W-4</b>	
CHECKED BY: DJR			<b>CITY OF RIPON</b>		
V: \25_ City of Ripon Standards \ Standard Specifications \ Drawings \ Water \ w-4.dwg					

- b) When a sanitary sewer and/or storm drain force main must cross a water line, the crossing should be as close as practical to the perpendicular. The sanitary sewer and/or storm drain force main should be at least one foot below the water line.
- c) When a new sanitary sewer and/or storm drain force main crosses under an existing water main, all portions of the sanitary sewer and/or storm drain force main within ten feet (horizontally) of the water main shall be enclosed in a continuous sleeve.
- d) When a new water main crosses over an existing sanitary sewer and/or storm drain force main, the water main shall be constructed of pipe materials with a minimum rated working pressure of 200 psi or equivalent pressure rating.

**D. ALTERNATIVE CRITERIA FOR CONSTRUCTION**

The construction criteria for sanitary sewer and/or storm drain lines or water mains where the basic separation standards cannot be attained are shown in City of Ripon Standards W-7 and W-7a. There are two situations encountered:

- Case 1 - new sanitary sewer and/or storm drain line being installed with either a new or existing water main. For this case, the alternative construction criteria apply to the sanitary sewer and/or storm drain line.
- Case 2 - new water main being installed with an existing sanitary sewer and/or storm drain line. For this case, the alternative construction criteria may apply to either or both the water main and the existing sanitary sewer and/or storm drain lines.

The construction criteria should apply to the house laterals that cross above a pressure water main, but not to those laterals that cross below a pressure water main.

CASE 1  
NEW SANITARY SEWER AND/OR STORM DRAIN LINE BEING INSTALLED  
(SEE CITY OF RIPON STANDARD W-7)

ZONE	SPECIAL CONSTRUCTION REQUIRED FOR SANITARY SEWER AND/OR STORM
A	Sanitary sewer and/or storm drain lines parallel to water mains shall not be permitted in this zone without approval from the responsible health agency and water supplier.
B	A sanitary sewer and/or storm drain line placed parallel to a water line shall be constructed of: <ol style="list-style-type: none"> <li>1. Extra strength vitrified clay pipe with compression joints.</li> <li>2. Plastic sewer pipe with rubber ring joints (per ASTM D3034) or equivalent.</li> <li>3. Cast or ductile iron pipe with compression joints.</li> <li>4. Reinforced concrete pressure pipe with compression joints (per AWWA C302-74).</li> </ol>
C	A sanitary sewer and/or storm drain line crossing a water main shall be constructed of: <ol style="list-style-type: none"> <li>1. Ductile iron pipe with hot-dip bituminous coating and mechanical joints.</li> <li>2. A continuous section of Class 200 (DR 14 per AWWA C900) plastic pipe or equivalent, centered on the pipe being crossed.</li> <li>3. A continuous section of reinforced concrete pressure pipe (per AWWA C302-74) centered over the pipe being crossed.</li> <li>4. Any sanitary sewer and/or storm drain pipe within a continuous sleeve.</li> </ol>
D	A sanitary sewer and/or storm drain line crossing a water main shall be constructed of: <ol style="list-style-type: none"> <li>1. A continuous section of ductile iron pipe with hot-dip bituminous coating.</li> <li>2. A continuous section of Class 200 (DR 14 per AWWA C900) plastic pipe or equivalent, centered on the pipe being crossed.</li> <li>3. A continuous section of reinforced concrete pressure pipe (per AWWA C302-774) centered over the pipe being crossed.</li> <li>4. Any sanitary sewer and/or storm drain pipe within a continuous sleeve.</li> <li>5. Any sanitary sewer pipe separated by a 10 foot by 10 foot, 4 inch thick reinforced concrete slab.</li> </ol>

NO.	REVISED	BY	<b>Criteria for Separation of Water Mains from SS/SD Lines</b>	APPROVED	
				 CITY ENGINEER RCE-28191	
DRAWN BY: MATT				DATE: 2-2-99	
CHECKED BY: DJR				STANDARD NO. <b>W-5</b>	
<small>V:\125_City of Ripon Standards\Standard Specifications\Drawings\Water\w-5.dwg</small>			CITY OF RIPON		

CASE 2  
NEW WATER MAIN BEING INSTALLED  
(SEE CITY OF RIPON STANDARD W-7a)

ZONE	SPECIAL CONSTRUCTION REQUIRED FOR WATER
A	No water mains parallel to sanitary sewer and/or storm drain lines shall be constructed without approval from the health agency.
B	If the sanitary sewer and/or storm drain line paralleling the water main does not meet the Case 1, Zone B requirements, the water main shall be constructed of: 1. Ductile iron pipe with hot dip bitumuous coating. 2. Class 200 pressure rated plastic water pipe (DR 14 per AWWA C900) or equivalent.
C	If the sanitary sewer and/or storm drain line crossing the water main does not meet the Case 1, Zone C requirements, the water main shall have no joints in Zone C and be constructed of: 1. Ductile iron pipe with hot dip bitumuous coating. 2. Class 200 pressure rated plastic water pipe (DR 14 per AWWA C900) or equivalent.
D	If the sanitary sewer and/or storm drain line crossing the water main does not meet the Case 1, Zone D requirements, the water main shall have no joints within 4 feet from either side of the sanitary sewer and/or storm drain line, and shall be constructed of: 1. Ductile iron pipe with hot dip bitumuous coating. 2. Class 200 pressure rated plastic water pipe (DR 14 per AWWA C900) or equivalent.

**NOTES AND DEFINITIONS:**

1. Health Agency - The Department of Health Services, Office of Drinking Water. For those water systems supplying fewer than 200 service connections, the local health officer of San Joaquin County shall act for the Department of Health Services.
2. Low Head Water Main - Any water main which has a pressure of 5 psi or less at any time, at any point in the main.
3. Dimensions - All dimensions are from the outside of water main to outside of sanitary sewer and/or storm drain line, or manhole.
4. Compression Joint - a push-on joint that seals by means of the compression of a rubber ring or gasket between the pipe and a bell or coupling.
5. Mechanical Joint - Bolted joints.
6. Rated Working Water Pressure or Pressure Class - A pipe classification system based upon internal working pressure of the fluid in the pipe, type of pipe material, and the thickness of the pipe wall.
7. Fused Joint - The joining of sections of pipe using thermal or chemical bonding process.
8. Sleeve - A protective tube of steel with a wall thickness of not less than one-fourth inch into which a pipe is inserted.
9. Groundwater - Subsurface water found in the saturation zone.
10. House Lateral - A sewer connecting the building drain and the main sewer line.
11. SS/SD - Indicates sanitary sewer (SS) and storm drain (SD).
12. Non-potable water system - Water system to be used for landscape irrigation purposes only.

NO.	REVISED	BY	<b>Criteria for Separation of Water Mains from SS/SD Lines</b>	APPROVED	
				 CITY ENGINEER RCE-28191	
				DATE: 2-2-99	
DRAWN BY: MATT			<b>CITY OF RIPON</b>	STANDARD NO.	<b>W-6</b>
CHECKED BY: DJR					
<small>V:\25_City of Ripon Standards\Standard Specifications\Drawings\Water\w-6.dwg</small>					

# CASE 1 - NEW SEWER OR STORM MAIN

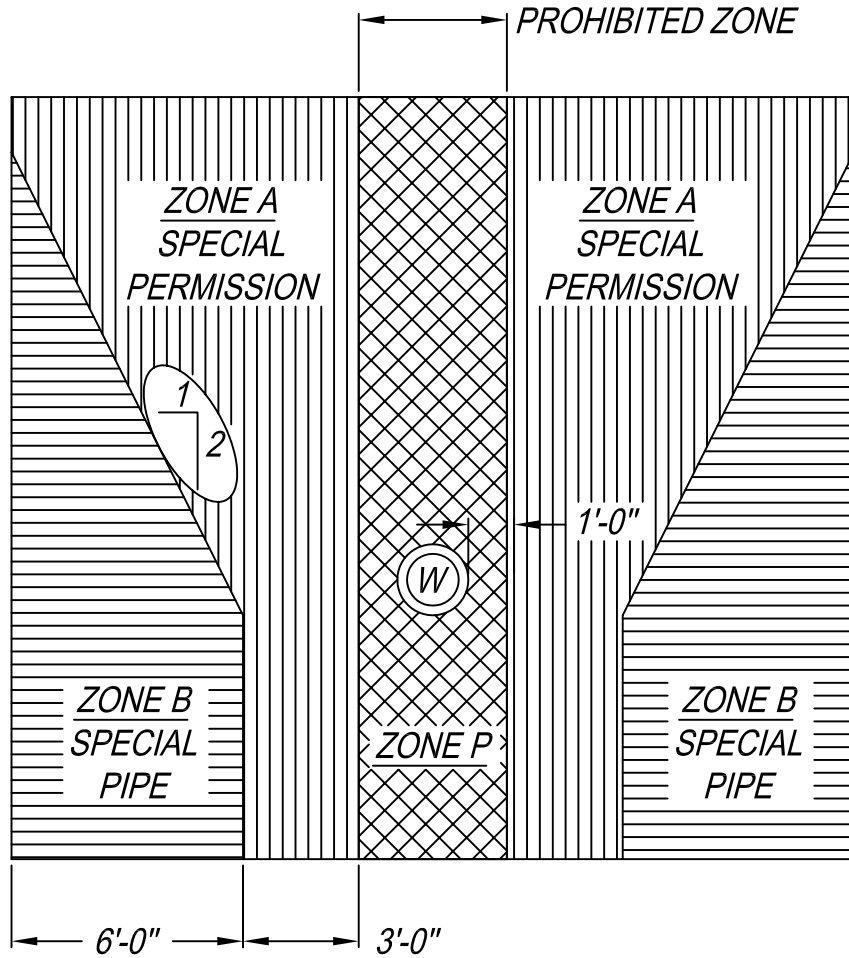

PARALLEL CONSTRUCTION

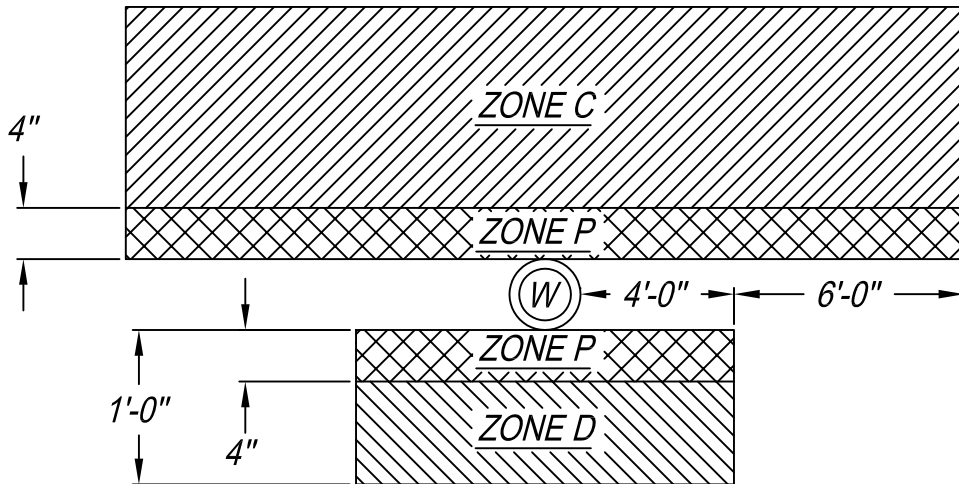

PERPENDICULAR (CROSSING) CONSTRUCTION

NO.	REVISED	BY	<p><b>Criteria for the Separation of Water Mains from Sanitary Sewer and Storm Drains - Case 1</b></p> <p style="font-size: 1.5em; font-weight: bold; margin-top: 20px;">CITY OF RIPON</p>	APPROVED	<p style="margin: 0;">CITY ENGINEER RCE-28191</p>
				DATE: 2-2-99	
DRAWN BY: MATT				STANDARD NO. <b>W-7</b>	
CHECKED BY: DJR					
V: \City of Ripon Standards \Standard Specifications \Drawings \Water \w-7.dwg					

# CASE 2 - NEW WATER MAIN

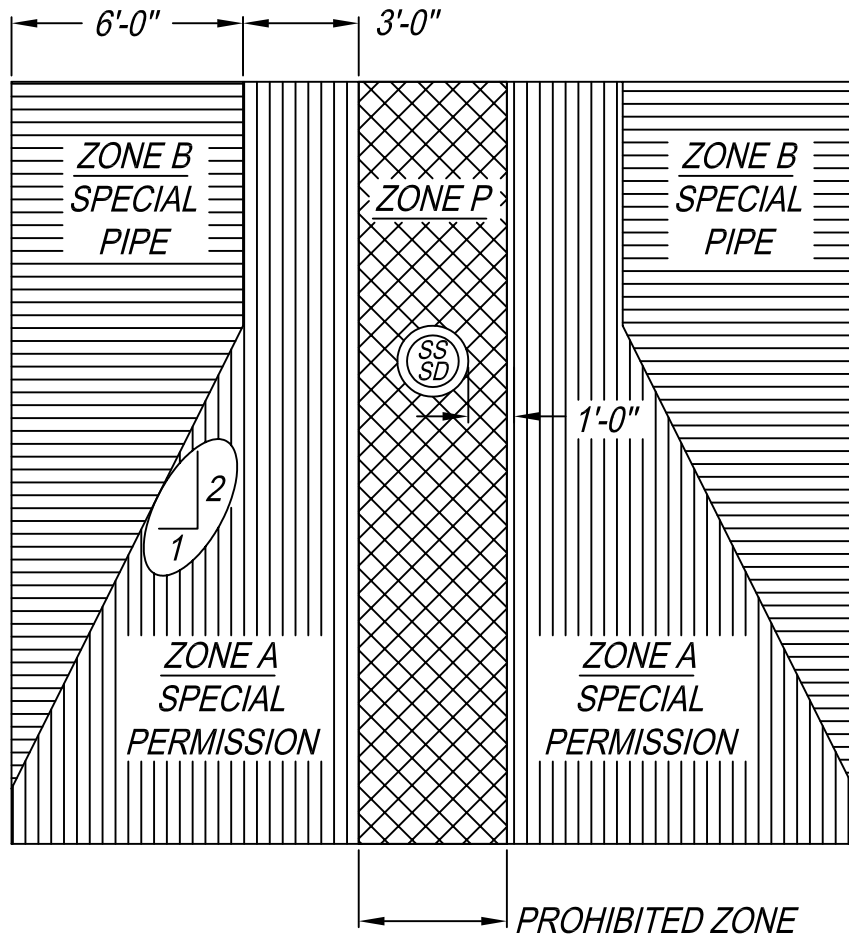

## PARALLEL CONSTRUCTION

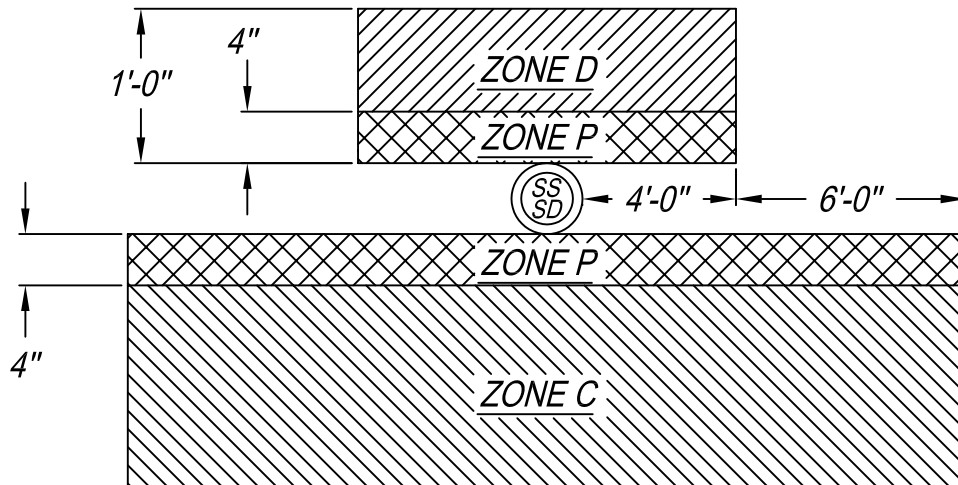

## PERPENDICULAR (CROSSING) CONSTRUCTION

NO.	REVISED	BY	<b>Criteria for the Separation of Water Mains from Sanitary Sewer and Storm Drains - Case 2</b>	APPROVED
				 CITY ENGINEER RCE-28191
DRAWN BY: MATT				DATE: 2-2-99
CHECKED BY: DJR				STANDARD NO. <b>W-7a</b>
<b>CITY OF RIPON</b>				

V: \City of Ripon Standards \Standard Specifications \Drawings \Water \w-7a.dwg

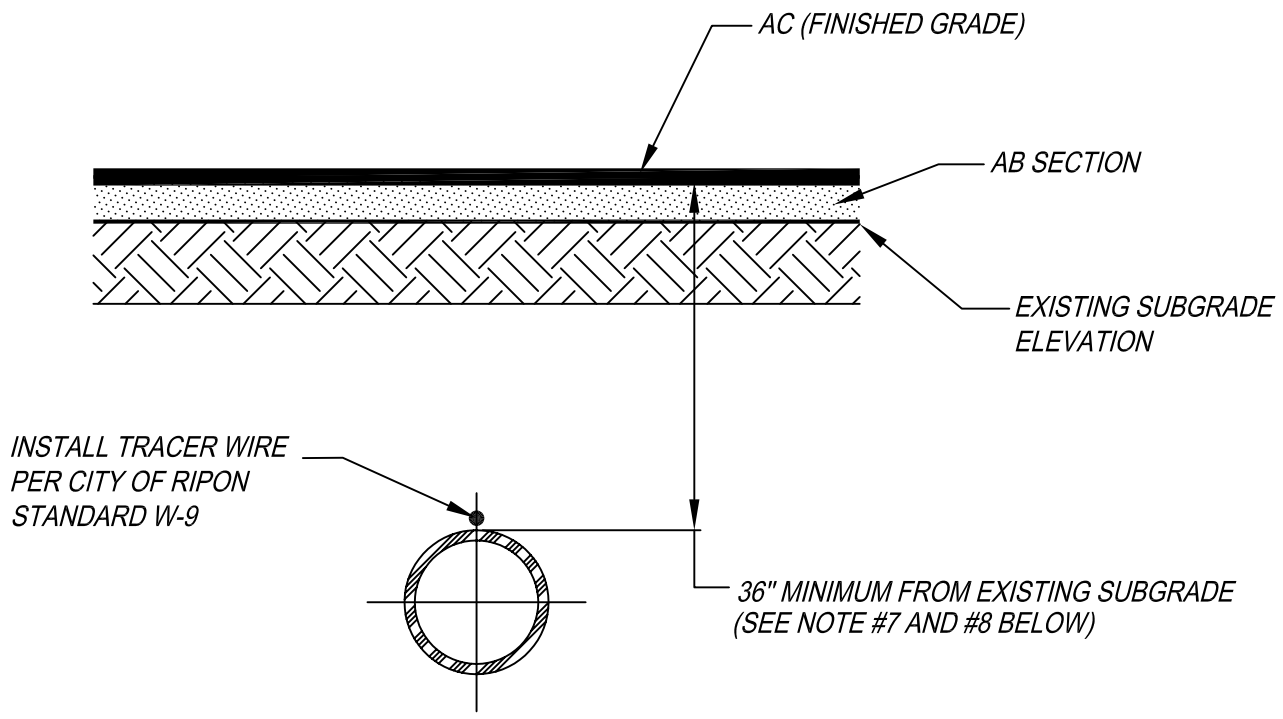

**NOTES:**

1. ALL WATER PIPES SHALL BE 8" IN DIAMETER, EXCEPT AS FOLLOWS:
  - A. 6" DIAMETER PIPE WILL BE ALLOWED ON "DEAD-END" RUNS THAT DO NOT EXCEED 150 FEET, DO NOT SERVE FIRE HYDRANTS, AND SERVE ONLY SINGLE FAMILY RESIDENTS.
  - B. 6" DIAMETER PIPE WILL BE ALLOWED UP TO 600 FEET IN LENGTH, PROVIDED IT IS LOOPED TO AN 8" DIAMETER PIPE OR LARGER, THERE ARE NO FIRE HYDRANTS LOCATED OFF OF THE 6" DIAMETER PIPE, AND THE 6" DIAMETER PIPE SERVES ONLY SINGLE FAMILY RESIDENTS.
  - C. IN ORDER TO PROMOTE BETTER CROSS CITY TRANSMISSION, THE CITY ENGINEER, MAY REQUIRE PIPE SIZES LARGER THAN 8" IN DIAMETER TO BE INSTALLED.
2. FIRE HYDRANT LOCATION AND PLACEMENT SHALL BE IN ACCORDANCE WITH THE CITY OF RIPON STANDARDS AND SPECIFICATIONS, AND AS DIRECTED BY THE CITY OF RIPON CONSOLIDATED FIRE DEPARTMENT.
3. GATE VALVES SHALL BE LOCATED SUCH THAT NOT MORE THAN 800 FEET OF WATER LINE WILL SHUT DOWN AT ANY ONE TIME, AND WILL NOT REQUIRE THE SHUT DOWN OF A MAIN TRANSMISSION WATER PIPE. IN NON-RESIDENTIAL AREAS, THE MAXIMUM VALVE SPACING SHALL BE 500 FEET.
4. ALL WATER LINES, VALVES, AND OTHER APPURTENANCES SHALL CONFORM TO AWWA AND CITY OF RIPON STANDARDS FOR 125# PIPE AND FITTINGS. EXCEPT AT SERVICE LINES, ALL VALVES SHALL BE 200# SERVICE RATED.
5. THE CONTRACTOR SHALL CALL THE CITY OF RIPON IF ANY LINES ARE BROKEN AS A RESULT OF HIS/HER OPERATIONS. NO WATER VALVE SHALL BE SHUT OFF BY ANYONE UNLESS SO DIRECTED BY AN AUTHORIZED REPRESENTATIVE OF THE CITY OF RIPON.
6. THE DESIGN OF NEW WATER PIPES SHALL BE SHOWN ON PLANS THAT INCLUDE GRADES DEPICTED IN PROFILE. SUCH PLANS SHALL BE SUBMITTED TO THE CITY ENGINEER FOR APPROVAL PRIOR TO START OF CONSTRUCTION.
7. FINISHED ELEVATION OF INSTALLED PIPE MAY HAVE TO BE DEEPER DUE TO GATE VALVE STEM COVERAGE FOR LARGER PIPE/GATE VALVE SIZES.
8. SPECIAL PERMISSION REQUIRED FROM CITY ENGINEER TO INSTALL PIPE WITH LESS COVERAGE THAN THE MINIMUM STANDARD COVERAGE.

NO.	REVISED	BY	<b>Water Design Data</b>	APPROVED  CITY ENGINEER RCE-28191
				DATE: 2-2-99
				STANDARD NO. <b>W-8</b>
DRAWN BY: MCP			<b>CITY OF RIPON</b>	
CHECKED BY: DJR				

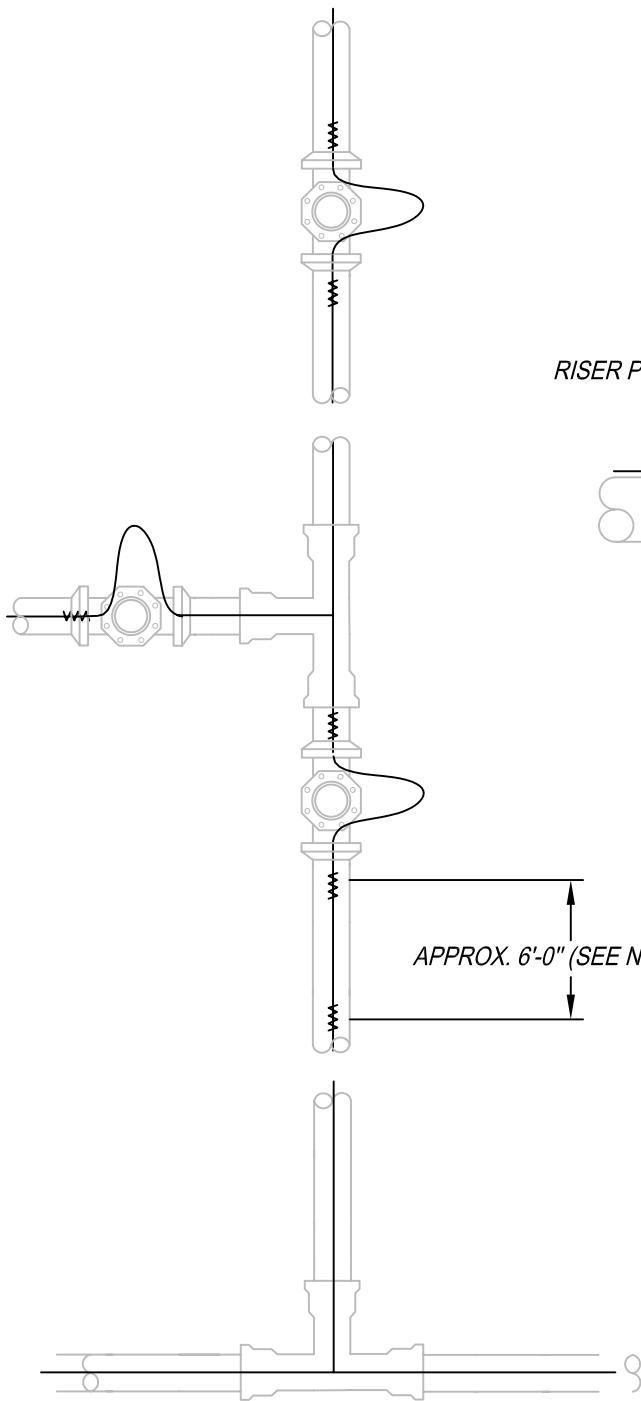

TYPICAL LAYOUT

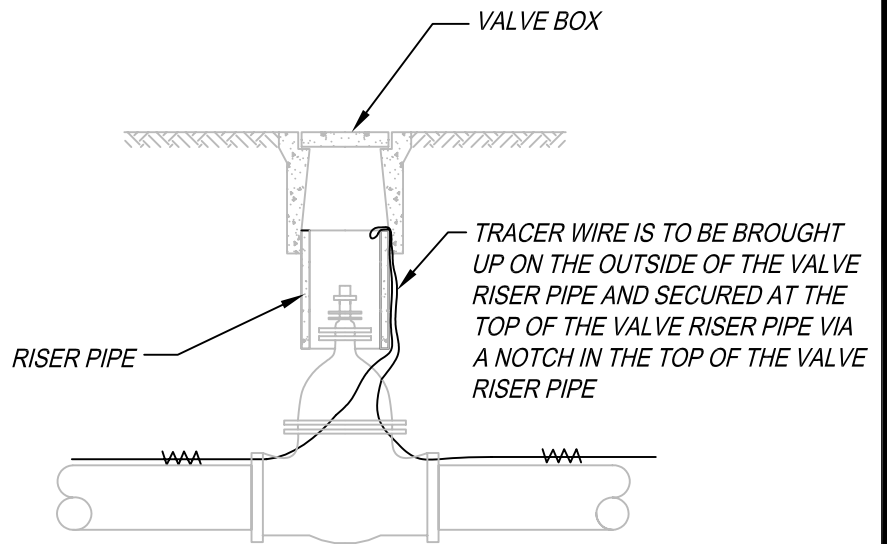

VALVE DETAIL

NOTES:

1. WIRE TO BE CONTINUOUS #10 AWG SINGLE STRAND INSULATED WIRE. INSULATION SHALL BE LIGHT OR BRIGHT IN COLOR.
2. WIRE SHALL BE SECURED TO THE CENTER OF THE TOP OF PIPE WITH TAPE AT 6 FOOT INTERVALS.
3. NO BARE WIRE IS TO TOUCH ANY VALVES OR FITTINGS.

NO.	REVISED	BY	<b>Tracer Wire Installation Detail</b>	APPROVED	 CITY ENGINEER RCE-28191
				DATE: 2-2-99	
				STANDARD NO. <b>W-9</b>	
DRAWN BY: MATT			<b>CITY OF RIPON</b>		
CHECKED BY: DJR					
<small>V:125_City of Ripon Standards   Standard Specifications   Drawings   Water   w-9.dwg</small>					

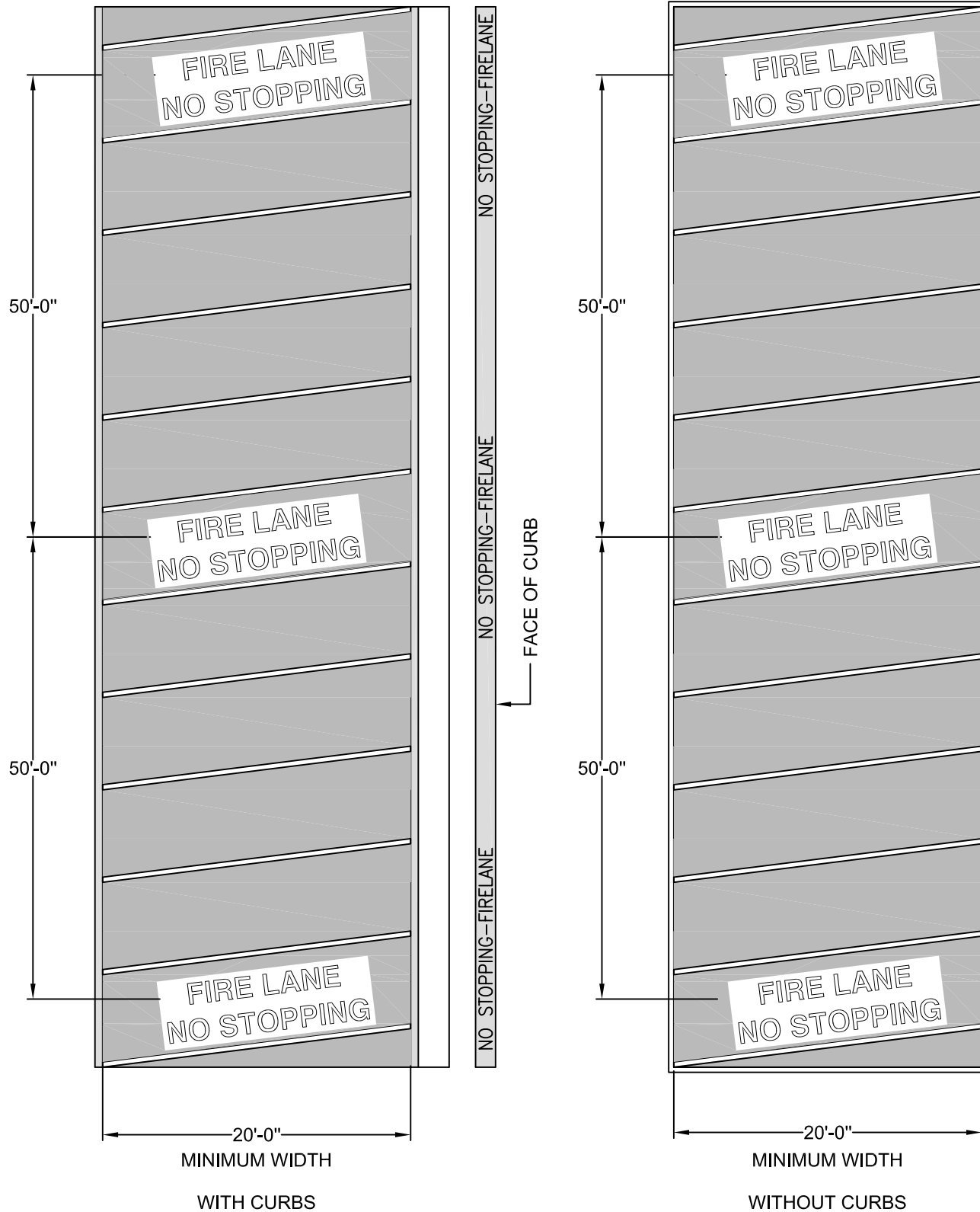

NO.	REVISED	BY
DRAWN BY: MCP		
CHECKED BY: DJR		
V:\25_City of Ripon Standards\Standard Specifications\Drawings\Water\w-10.dwg		

**Fire Lane  
Details**

**CITY OF RIPON**

APPROVED  
  
 CITY ENGINEER 58093  
 DATE: 11-07-00  
 STANDARD NO. **W-10**



ALL FIRE LANES REQUIRED BY THE RIPON CONSOLIDATED FIRE DISTRICT ARE REQUIRED TO MEET THE REQUIREMENTS OF CITY OF RIPON STANDARD W-10.

**WIDTH:** FIRE LANES ARE REQUIRED TO BE A MINIMUM OF TWENTY (20) FEET IN WIDTH, ALONG THE FULL LENGTH OF REQUIRED LANE.

**SURFACE:** FIRE LANES ARE TO BE CONSTRUCTED OF ASPHALT OR CONCRETE, UNLESS APPROVED OTHERWISE BY THE CITY ENGINEER AND THE FIRE MARSHALL.

**MARKING:**

1. CURBS ON EITHER SIDE OF LANE SHALL BE PAINTED RED AND THE WORDS "NO STOPPING - FIRE LANE" ARE TO BE PAINTED ON THE FACE OF CURB. THESE LETTERS ARE TO BE A MINIMUM OF 4 INCHES IN HEIGHT AND ARE TO BE WHITE IN COLOR, AND SPACED AT INTERVALS OF NOT MORE THAN 25 FEET APART.
2. IF NO CURBS ARE PRESENT TO DELINEATE THE WIDTH OF THE LANE, THE OUTER BOUNDARIES OF THE LANE WILL BE MARKED WITH A RED LINE THAT IS A MINIMUM OF 4 INCHES IN WIDTH. THE LINE SHALL RUN THE FULL LENGTH OF REQUIRED LANE, AND PLACED ON ANY SIDE THAT IS NOT BORDERED BY A CURB.
3. THE ENTIRE FIRE LANE SHALL BE MARKED WITH DIAGONAL PAINTED WHITE LINES, RUNNING ACROSS THE FULL WIDTH OF THE LANE. THESE LINES ARE TO BE SPACED NO MORE THAN TEN (10) FEET APART AND ARE TO BE NO LESS THAN 2.5 INCHES IN WIDTH.
4. THE WORDS "FIRE LANE - NO STOPPING" ARE TO BE PAINTED ON THE DRIVING SURFACE AT A SPACING NOT TO EXCEED EVERY FIFTY (50) FEET, UNLESS OTHERWISE SPECIFIED. THE LETTERS ARE TO BE NO LESS THAN 8 INCHES TALL UNLESS APPROVED BY THE CITY ENGINEER AND FIRE MARSHALL.

**SIGNAGE:** SIGNS SHALL BE POSTED AT EACH ENTRANCE AND EVERY 75 FEET IN BETWEEN, STATING "NO STOPPING - FIRE LAND". THE SIGN SHALL MEET THE REQUIRMENTS OF THE CALIFORNIA DEPARTMENT OF TRANSPORTATION, SIGN NUMBER R26F. THE SIGN IS ALSO TO STATE "CVC 22500.1".



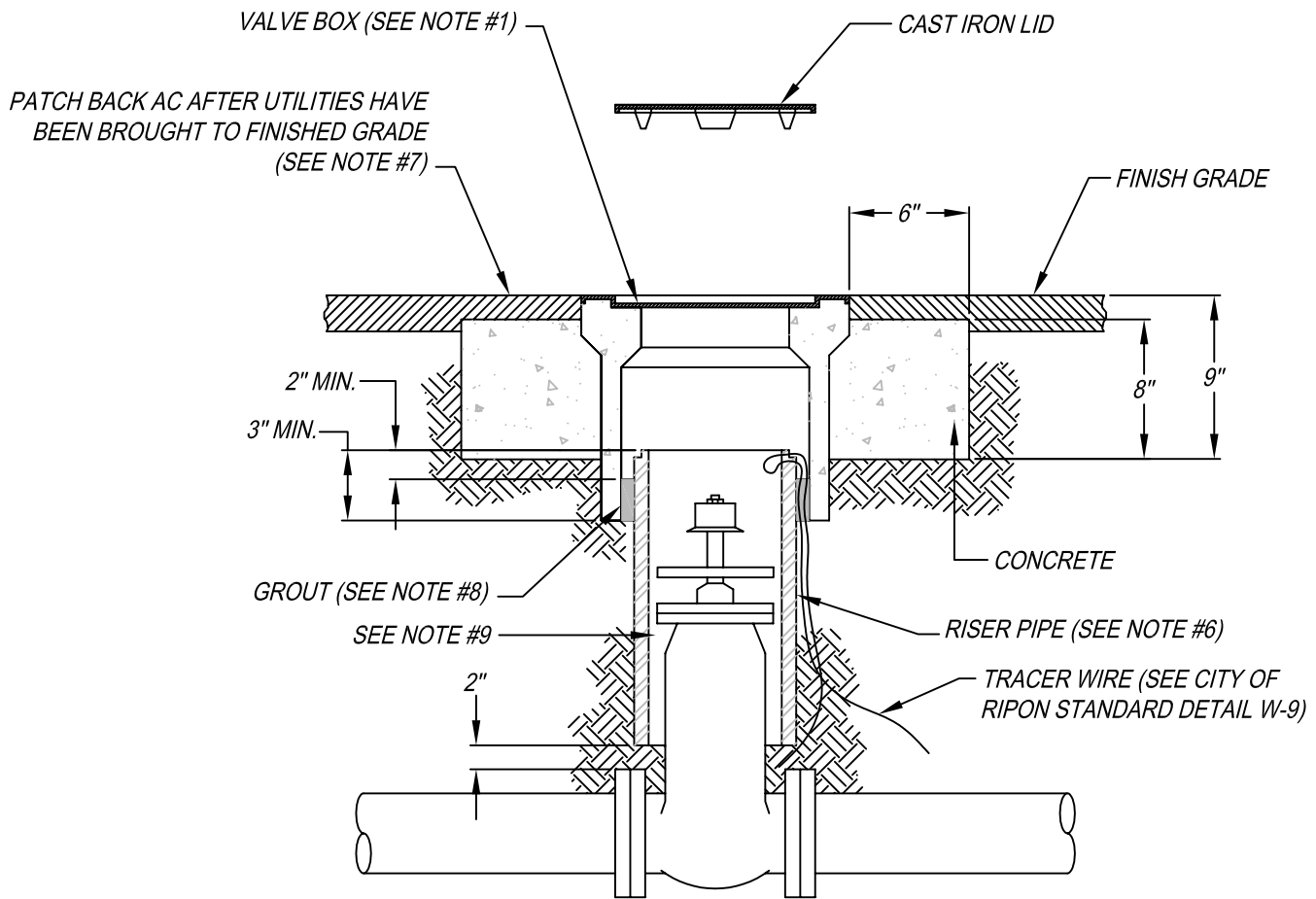

NO.	REVISED	BY	<b>Fire Lane Notes</b>	APPROVED	
				CITY ENGINEER	58093
DRAWN BY: MCP				DATE:	11-07-00
CHECKED BY: DJR				<b>CITY OF RIPON</b>	
V: \25_City of Ripon Standards \Standard Specifications \Drawings \Water \w-10a.dwg					

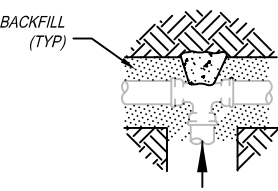
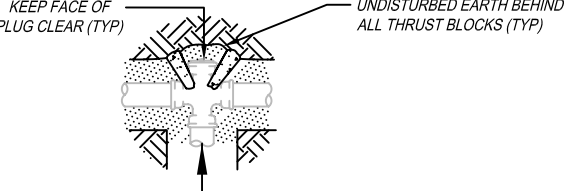
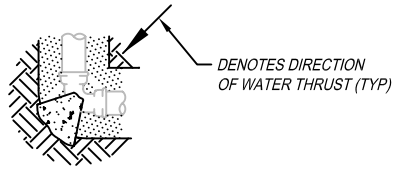

**NOTES:**

1. VALVE BOX AND LID SHALL BE:
  - A. POTABLE WATER - CHRISTY NO. G8 TRAFFIC BOX OR EQUAL.
  - B. NON-POTABLE WATER - STANDARD CONCRETE BOX (G8 SIZE) WITH SPECIAL TRIANGULAR HEAVY DUTY COVER. COVER SHALL BE MARKED "NPW".
2. ALL LIDS SHALL HAVE A MACHINED SEATING SURFACE.
3. VALVE NUT DEPTH SHALL NOT EXCEED 4'-0" FROM FINISHED GRADE. IF IT DOES EXCEED 4'-0", THEN A VALVE NUT EXTENSION SHALL BE INSTALLED TO BRING VALVE NUT INTO COMPLIANCE.
4. CONCRETE COLLAR IS NOT REQUIRED WHEN VALVE BOX IS LOCATED WITHIN A CONCRETE SIDEWALK AREA.
5. FOR BLOWOFF INSTALLATION, REFER TO CITY OF RIPON STANDARD W-16.
6. RISER PIPE TO BE ONE CONTINUOUS PIECE OF PVC PIPE (C900 CLASS 150 WATER PIPE). MINIMUM PIPE SIZE TO BE USED AS A RISER PIPE IS 8" DIAMETER.
7. AC PATCH TO BE NO MORE THAN 1" IN DEPTH AND NO LESS THAN 1/2" IN DEPTH.
8. GROUT BETWEEN ENTIRE RISER PIPE AND VALVE BOX, GROUT SHALL BE A MINIMUM OF 1" THICK.
9. THE DIRT SHALL BE A MINIMUM OF 2" BELOW THE VALVE NUT.

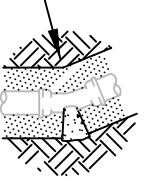
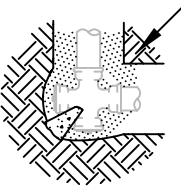
NO.	REVISED	BY	<b>Valve Box Details</b>		APPROVED
					 CITY ENGINEER RCE-28191
DRAWN BY: TP			DATE: 2-2-99		
CHECKED BY: DJR			<b>CITY OF RIPON</b>		STANDARD NO. <b>W-11</b>
<small>V:\125_City of Ripon Standards\Standard Specifications\Drawings\Water\w-11.dwg</small>					

	TYPE OF FITTING	REQUIRED TOTAL BEARING AREAS, SQUARE FEET					
		PIPE SIZES					
		6"	8"	10"	12"	14"	16"
	TEE OR DEAD END	2	3	4.5	6	8	10
	CROSS AND PLUG	3	4.5	6.5	9	12	15
	90° ELBOW	2.5	4	6	9	11	14
	45° ELBOW	1.5	2.5	3.5	5	6	8
	22-1/2° ELBOW	1	1	2	2.5	3	4
	CROSS AND PLUGS	2.5	4	6	9	11	14
	TEE AND PLUGS	2.5	4	6	9	11	14

**NOTES:**

1. THE ABOVE MENTIONED BEARING AREAS ARE BASED ON 100 psi SERVICE PRESSURE, AND 2,000 psi SOIL BEARING CAPACITY. WHERE SOIL CONDITIONS REQUIRE ADJUSTMENT OF ALLOWABLE BEARING PRESSURE, IN THE OPINION OF THE ENGINEER, REQUIRED BLOCKING AREAS WILL BE ADJUSTED.
2. FOR PIPE SIZES LARGER THAN THAT SHOWN, THE DESIGN ENGINEER SHALL SUBMIT DESIGN CALCULATIONS FOR THRUST BLOCKS.
3. WHEN USING THRUST BLOCKS, RESTRAINT JOINTS ARE NOT REQUIRED.
4. VISQUEEN SHALL BE PLACED BETWEEN ALL THRUST BLOCKS AND PIPE FITTINGS.

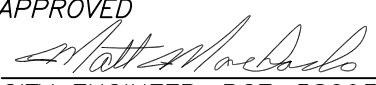
NO.	REVISED	BY	<b>Thrust Block Details</b>	APPROVED
	3/2002	M		 CITY ENGINEER RCE-58093
DRAWN BY: MCP				DATE:
CHECKED BY: DJR			<b>CITY OF RIPON</b>	STANDARD NO. <b>W-12</b>
V: 1.25_City of Ripon Standards   Standard Specifications   Drawings   Water   w-12.dwg				

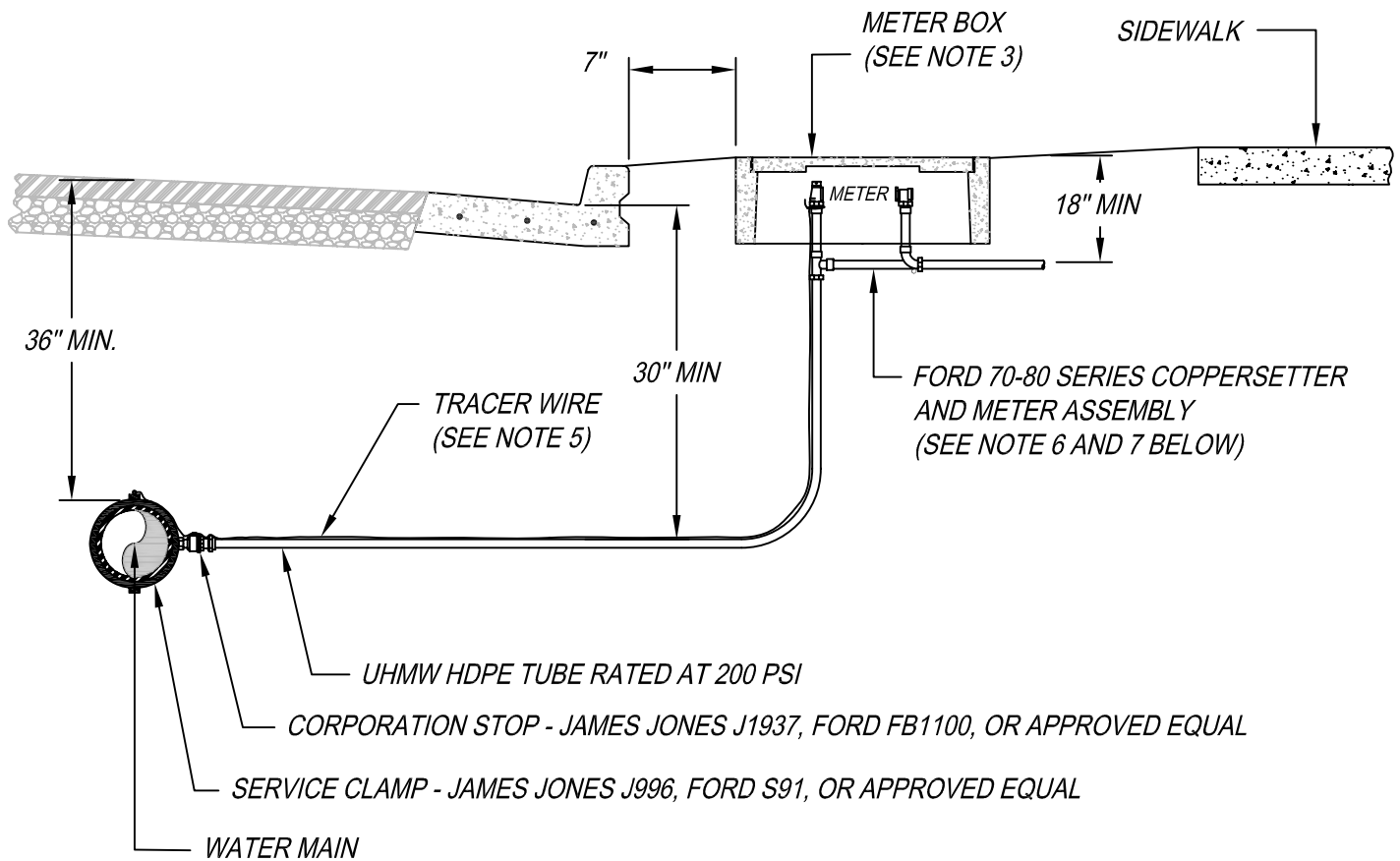

**NOTES:**

1. UHMW HDPE TUBING TO BE CONTINUOUS (NO JOINTS) BETWEEN MAIN AND METER STOP.
2. THE LOCATION OF THE TAP ON THE MAIN LINE, SHALL BE A MINIMUM OF 2'-0" FROM ANOTHER TAP, PIPE BELL, PIPE SPIGOT, OR OTHER FITTINGS.
3. METER BOX SHALL BE CHRISTY NO. B-36 OR APPROVED EQUAL. BOXES IN TRAFFIC AREAS SHALL HAVE TRAFFIC RATED COVERS. ALL COVERS SHALL HAVE A METER READING LID, A CHRISTY B36g IN NON-TRAFFIC AREAS AND A CHRISTY B36-61g IN TRAFFIC AREAS.
4. METER BOX SHALL BE 7 INCHES BEHIND BACK OF CURB FOR SEPARATED SIDEWALK, OR 7 INCHES BEHIND SIDEWALK FOR ATTACHED SIDEWALK.
5. WATER SERVICE TRACER WIRE SHALL BE SPLICED TO THE WATER MAIN TRACER WIRE AND TERMINATED AT THE TOP OF THE METER SETTER BY WRAPPING IT AROUND THE TOP OF THE METER SETTER NEAR THE METER INLET FLANGE. TRACER WIRE SHALL BE SECURED, WITH TAPE, TO THE UHMW WATER SERVICE LINE AT APPROXIMATELY 2 FOOT INTERVALS.
6. METER SETTER:
  - A. FOR 1-1/2" WATER SERVICE USE METER SETTER - FORD 70-80 SERIES COPPERSETTER (VBH-76-86-15-11-66 WITH C84-66 ADAPTER)
  - B. FOR 2" WATER SERVICE DO NOT USE METER SETTER, USE THE FOLLOWING PARTS:
    - 1) METER INLET SIDE - BALL VALVE (FORD BFA43-777W) AND HDPE TUBING ADAPTER (FORD C86-77-IDR7),
    - 2) METER DISCHARGE SIDE - CHECK VALVE (FORD HFA31-777) AND PVC PIPE ADAPTER (FORD C87-77).
7. WATER METER:
  - A. FOR 1-1/2" WATER SERVICE USE WATER METER - BADGER M120 WITH TRACE PIT TRANSPONDER REGISTERED IN CUBIC FOOT.
  - B. FOR 2" WATER SERVICE USE WATER METER - BADGER M170 WITH TRACE PIT TRANSPONDER REGISTERED IN CUBIC FOOT.
8. USE OF A 1-1/2" OR 2" WATER SERVICE FOR A RESIDENTIAL LOT REQUIRES SPECIAL PERMISSION FROM THE CITY OF RIPON.
9. A REMOTE METER READER SHALL BE INSTALLED WITH EVERY WATER METER. FOR INSTALLATION DETAILS AND A PART DESCRIPTION SEE CITY OF RIPON STANDARD DETAIL W-15.
10. ALL WATER METERS SHALL BE PROVIDED AND INSTALLED BY THE DEVELOPER AND/OR CONTRACTOR.

NO.	REVISED	BY	<b>1-1/2" and 2" Metered Water Service Installation</b>	APPROVED
				 CITY ENGINEER RCE-28191
DRAWN BY: MCP				DATE: 2-2-99
CHECKED BY: DJR				STANDARD NO. <b>W-13</b>
<small>V:\25_City of Ripon Standards\Standard Specifications\Drawings\Water\w-13.dwg</small>				<b>CITY OF RIPON</b>

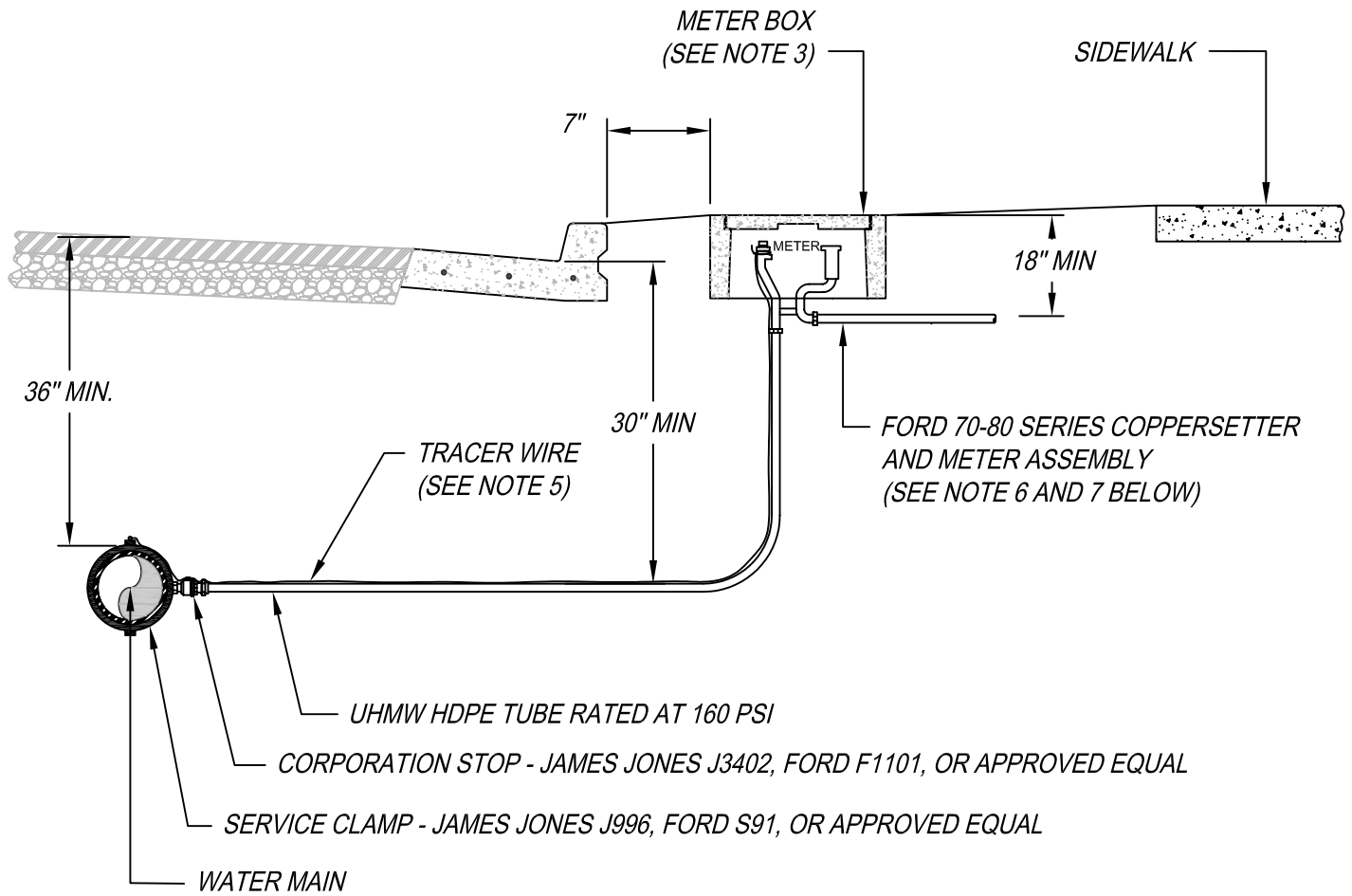

**NOTES:**

1. UHMW HDPE TUBING TO BE CONTINUOUS (NO JOINTS) BETWEEN MAIN AND METER STOP.
2. THE LOCATION OF THE TAP ON THE MAIN LINE, SHALL BE A MINIMUM OF 2'-0" FROM ANOTHER TAP, PIPE BELL, PIPE SPIGOT, OR OTHER FITTINGS.
3. METER BOX SHALL BE CHRISTY NO. B-16 OR APPROVED EQUAL. BOXES IN TRAFFIC AREAS SHALL HAVE TRAFFIC RATED COVERS. ALL COVERS SHALL HAVE A METER READING LID, A CHRISTY B16g IN NON-TRAFFIC AREAS AND A CHRISTY B16-61g IN TRAFFIC AREAS.
4. METER BOX SHALL BE 7 INCHES BEHIND BACK OF CURB FOR SEPARATED SIDEWALK, OR 7 INCHES BEHIND SIDEWALK FOR ATTACHED SIDEWALK.
5. WATER SERVICE TRACER WIRE SHALL BE SPLICED TO THE WATER MAIN TRACER WIRE AND TERMINATED AT THE TOP OF THE METER SETTER BY WRAPPING IT AROUND THE TOP OF THE METER SETTER NEAR THE METER INLET FLANGE. TRACER WIRE SHALL BE SECURED, WITH TAPE, TO THE UHMW WATER SERVICE LINE AT APPROXIMATELY 2 FOOT INTERVALS.
6. METER SETTER:
  - A. FOR 1" WATER SERVICE USE METER SETTER - FORD 70-80 SERIES CCOPPERSETTER (VBH-74-84-11-44 WITH C86-44 ADAPTER)
7. WATER METER:
  - A. FOR 1" WATER SERVICE USE WATER METER - BADGER M70 WITH TRACE PIT TRANSPONDER REGISTERED IN CUBIC FOOT.
8. A REMOTE METER READER SHALL BE INSTALLED WITH EVERY WATER METER. FOR INSTALLATION DETAILS AND A PART DESCRIPTION SEE CITY OF RIPON STANDARD DETAIL W-15.
9. ALL WATER METERS SHALL BE PROVIDED AND INSTALLED BY THE DEVELOPER AND/OR CONTRACTOR.

NO.	REVISED	BY	<b>1" Metered Water Service Installation</b>	APPROVED
				 CITY ENGINEER RCE-28191
				DATE: 2-2-99
DRAWN BY: MCP			<b>CITY OF RIPON</b>	STANDARD NO. <b>W-14</b>
CHECKED BY: DJR				
V: 125 City of Ripon Standards   Standard Specifications   Drawings   Water   w-14.dwg				

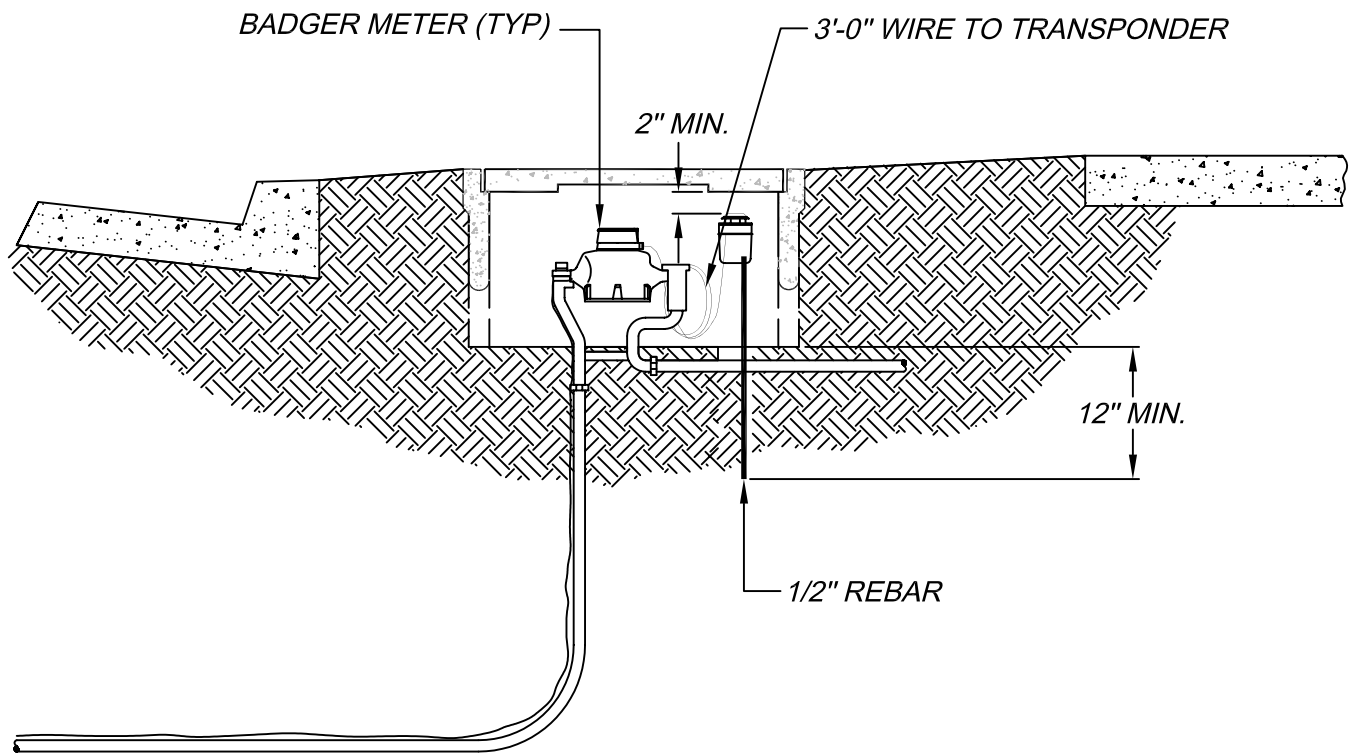

**NOTES:**

1. FOR CAST IRON LIDS, USE PT THROUGH-HOLE INSTALLATION KIT P/N 62310-005.
2. FOR WATER METER, METER SETTER, AND METER BOX INFORMATION SEE CITY OF RIPON'S STANDARD DETAILS W-13 OR W-14.

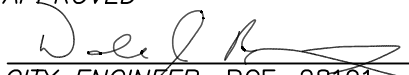
NO.	REVISED	BY	<b>Remote Meter Read Installation</b>	APPROVED
				 CITY ENGINEER RCE-28191
				DATE: 2-2-99
DRAWN BY: MCP			<b>CITY OF RIPON</b>	STANDARD NO. <b>W-15</b>
CHECKED BY: DJR				
<small>V:\125_City of Ripon Standards\Standard Specifications\Drawings\Water\W-15.dwg</small>				

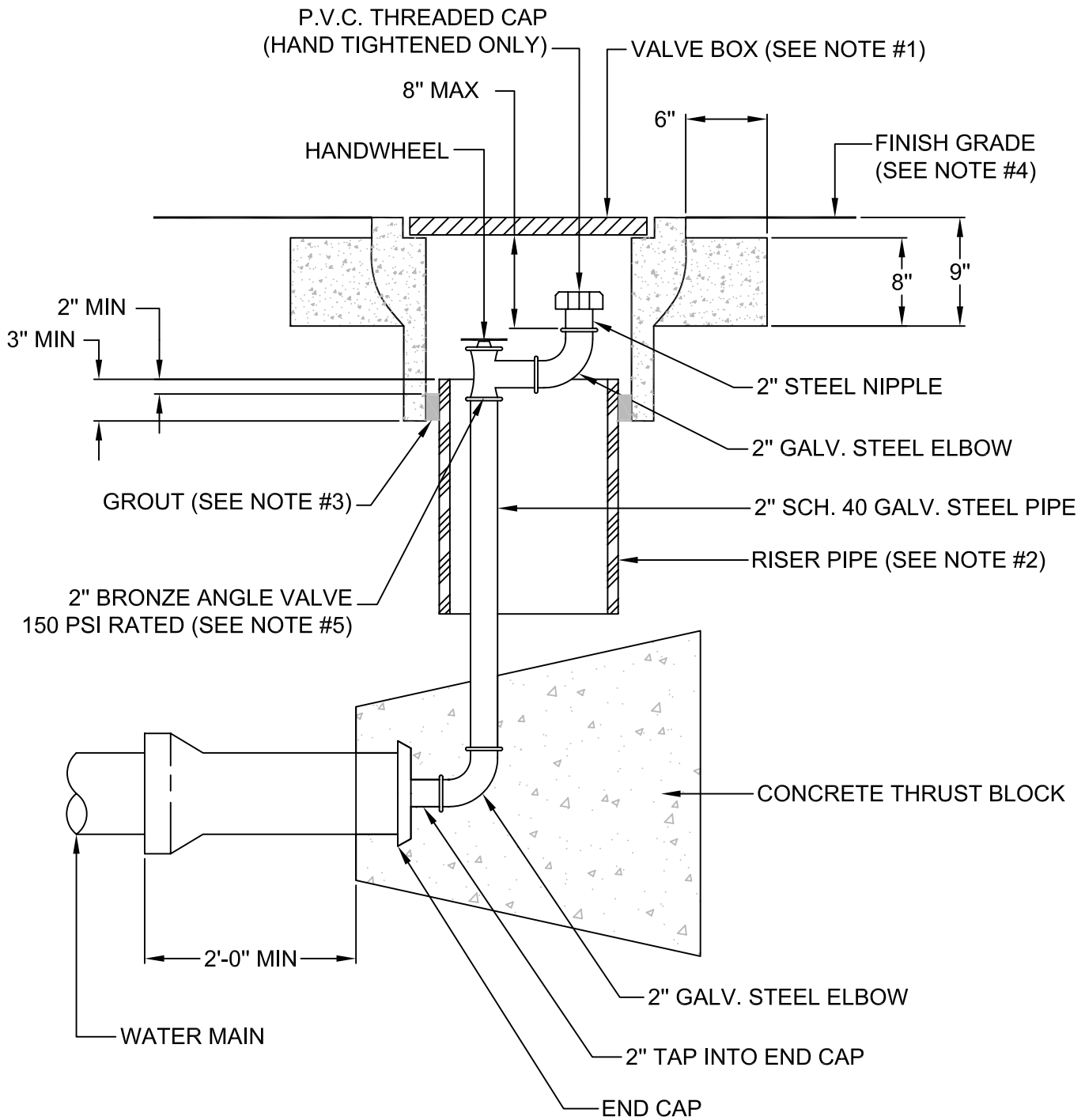

**NOTES:**

1. VALVE BOX SHALL BE CHRISTY NO. G12 TRAFFIC BOX OR EQUAL.
2. RISER PIPE TO BE ONE CONTINUOUS PIECE OF PVC PIPE (C900 CLASS 150 WATER PIPE). MINIMUM PIPE SIZE TO BE USED AS A RISER PIPE IS 12" DIAMETER. A CHRISTY G12 x P12 BOX EXTENSION OR AN APPROVED EQUAL MAY ALSO BE USED.
3. GROUT BETWEEN ENTIRE RISER PIPE AND VALVE BOX, GROUT SHALL BE A MINIMUM OF 1" THICK.
4. AC PATCH TO BE NO MORE THEN 1" IN DEPTH AND NO LESS THAN 1/2" IN DEPTH.
5. THE DIRT SHALL BE A MINIMUM OF 2" BELOW THE ANGLE VALVE.

NO.	REVISED	BY	<b>Permanent and Temporary Blowoff Detail</b>	APPROVED	 CITY ENGINEER RCE-28191
				DATE: 2-2-99	
				STANDARD NO. <b>W-16</b>	
DRAWN BY: MCP			<b>CITY OF RIPON</b>		
CHECKED BY: DJR					
V:\25_City of Ripon Standards\Standard Specifications\Drawings\Water\W-16.dwg					

***THIS PAGE  
INTENTIONALLY LEFT BLANK***

<i>NO.</i>	<i>REVISED</i>	<i>BY</i>		<i>APPROVED</i>
				<i>CITY ENGINEER RCE-28191</i>
				<i>DATE:</i>
<i>DRAWN BY:</i>			<b><i>CITY OF RIPON</i></b>	<i>STANDARD NO. W-17</i>
<i>CHECKED BY:</i>				
<small>V:\25_City of Ripon Standards\Standard Specifications\Drawings\Water\W-17.dwg</small>				



*THIS PAGE  
INTENTIONALLY LEFT BLANK*

<i>NO.</i>	<i>REVISED</i>	<i>BY</i>		<i>APPROVED</i>
				<i>CITY ENGINEER RCE-28191</i>
				<i>DATE:</i>
<i>DRAWN BY:</i>			<b><i>CITY OF RIPON</i></b>	<i>STANDARD NO. W-18</i>
<i>CHECKED BY:</i>				
<small>V:\25_City of Ripon Standards\Standard Specifications\Drawings\Water\W-18.dwg</small>				

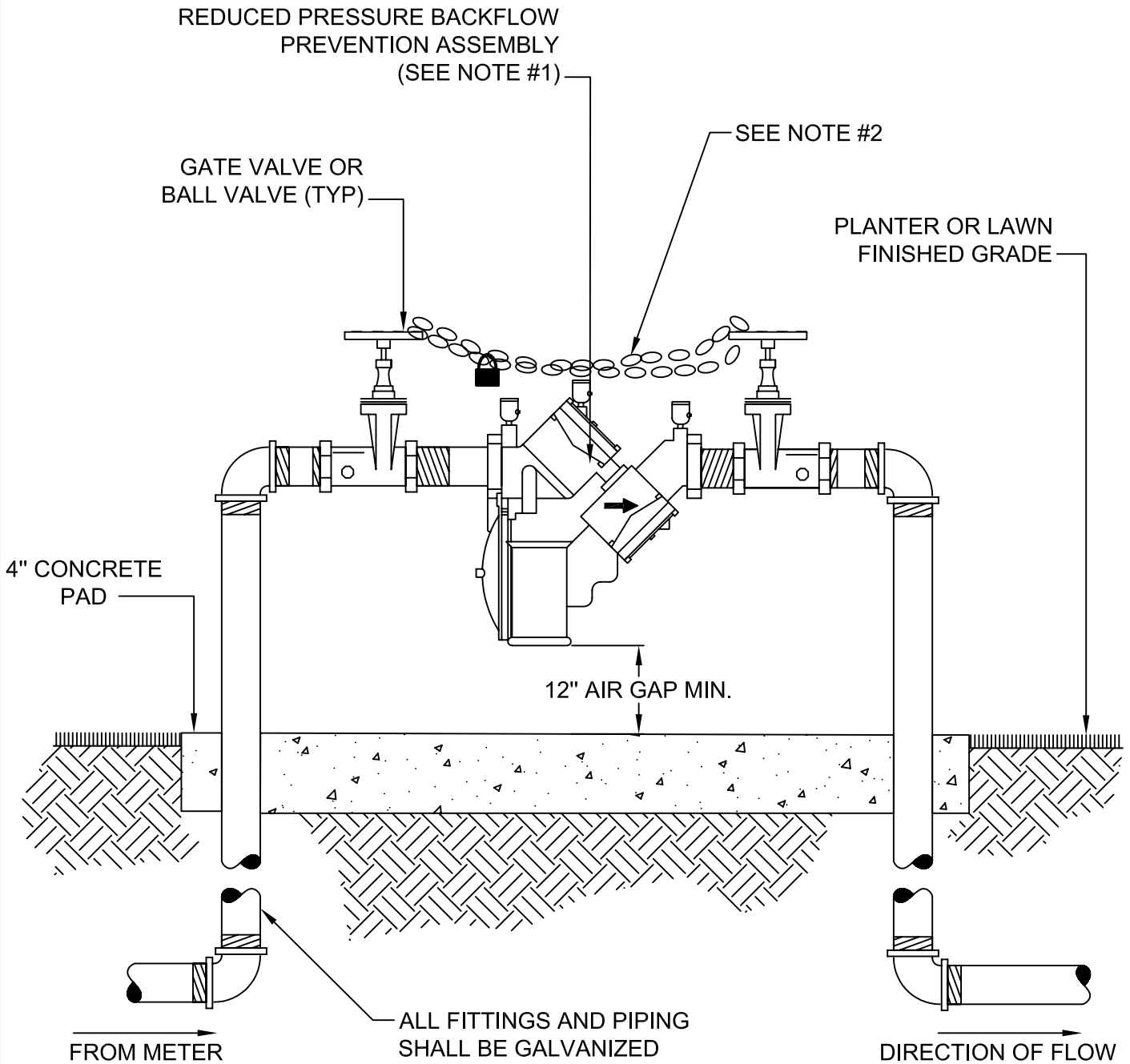

**NOTES:**

1. REDUCED PRESSURE BACKFLOW PREVENTION DEVICE SHALL BE AN APPROVED BACKFLOW PREVENTION ASSEMBLY BY THE STATE OF CALIFORNIA DEPARTMENT OF HEALTH SERVICES. (SOME APPROVED EXAMPLES INCLUDE: WILKINS/ZURN 975XL, FEBCO 825Y, ETC.)
2. ONCE INSTALLED AND FUNCTIONING THE GATE VALVES SHOULD BE CHAINED AND LOCKED OPEN.
3. INSTALL A 12" AIR GAP MINIMUM BETWEEN FINISHED GRADE AND RP DEVICE.

NO.	REVISED	BY	<p><b>Reduced Pressure Principle Backflow Prevention Assembly for 1" to 2-1/2" Pipe Size</b></p> <p><b>CITY OF RIPON</b></p>	APPROVED	 CITY ENGINEER RCE-28191
				DATE: 2-2-99	
DRAWN BY: MCP					STANDARD NO. <b>W-19</b>
CHECKED BY: DJR					
<small>V:\25_City of Ripon Standards\Standard Specifications\Drawings\Water\W-19.dwg</small>					

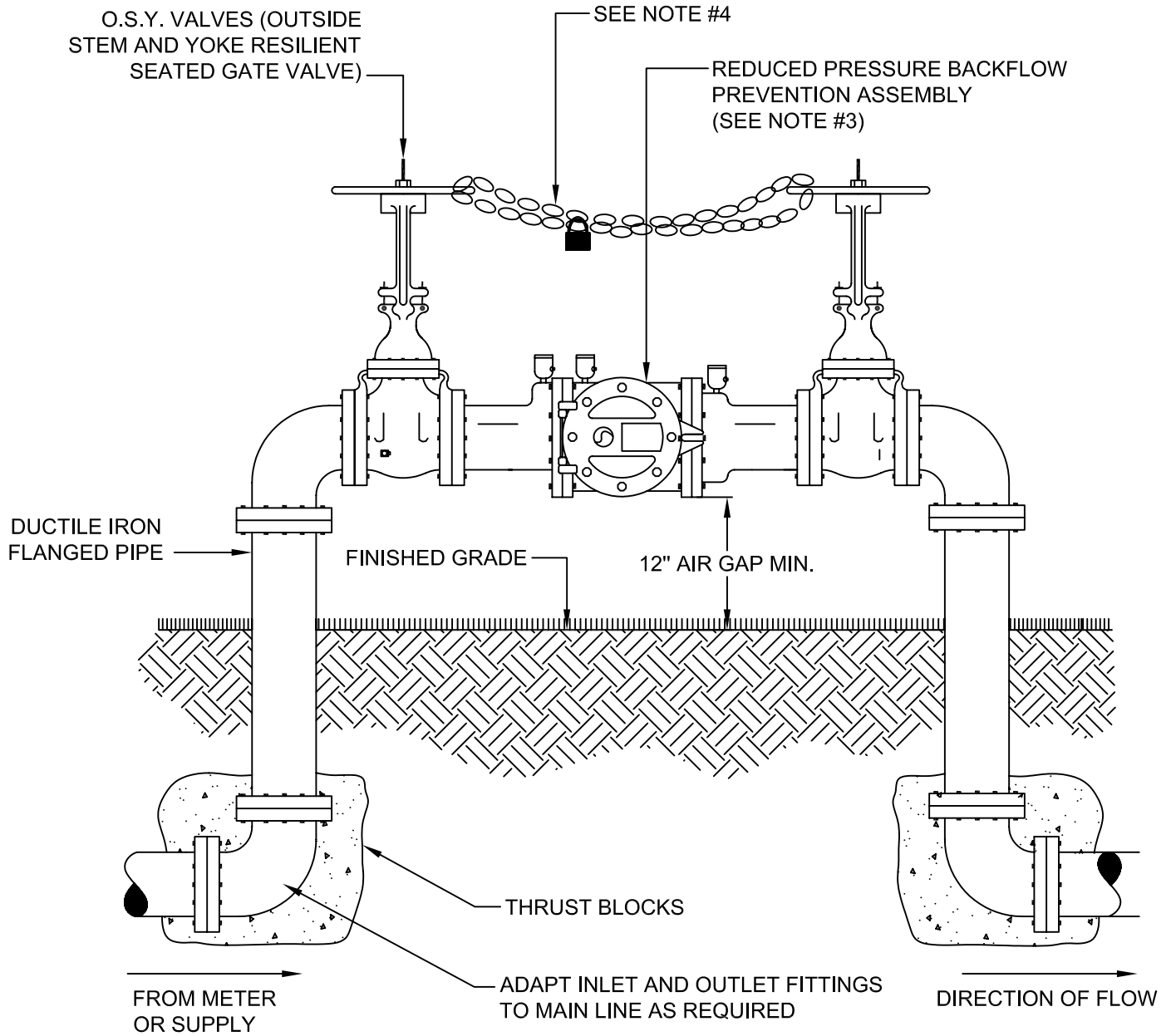

**NOTES:**

1. INSTALL A 12" AIR GAP MINIMUM BETWEEN FINISHED GRADE AND RP DEVICE.
2. ALL CONNECTIONS ON ASSEMBLY SHALL BE FLANGED FITTINGS.
3. REDUCED PRESSURE BACKFLOW PREVENTION DEVICE SHALL BE AN APPROVED BACKFLOW PREVENTION ASSEMBLY BY THE STATE OF CALIFORNIA DEPARTMENT OF HEALTH SERVICES. (SOME APPROVED EXAMPLES INCLUDE: AMES 400SS OSY, WILKINS 375, WILKINS 975, ETC.)
4. ONCE INSTALLED AND FUNCTIONING THE GATE VALVES SHOULD BE CHAINED AND LOCKED OPEN.

NO.	REVISED	BY	<p><b>Reduced Pressure Principle Backflow Prevention Assembly for 3" and Larger</b></p>	APPROVED	 CITY ENGINEER RCE-28191
				DATE: 2-2-99	
DRAWN BY: MCP				CITY OF RIPON	STANDARD NO. <b>W-20</b>
CHECKED BY: DJR					
V:\25_City of Ripon Standards\Standard Specifications\Drawings\Water\W-20.dwg					

IF FIRE HYDRANT IS LOCATED AT THE ENTRANCE OF THE CUL-DE-SAC AND THE CUL-DE-SAC LENGTH IS LESS THAN 350 FEET, THEN NO FIRE HYDRANT IS NEEDED ON THE CUL-DE-SAC

IF FIRE HYDRANT IS NEEDED IN A CUL-DE-SAC IT SHALL BE PLACED AT THE BEGINNING OF THE BULB. ADDITIONAL RIGHT-OF-WAY MAY BE REQUIRED TO ENSURE THAT THE FIRE HYDRANT IS LOCATED WITHIN THE CITY RIGHT-OF-WAY.

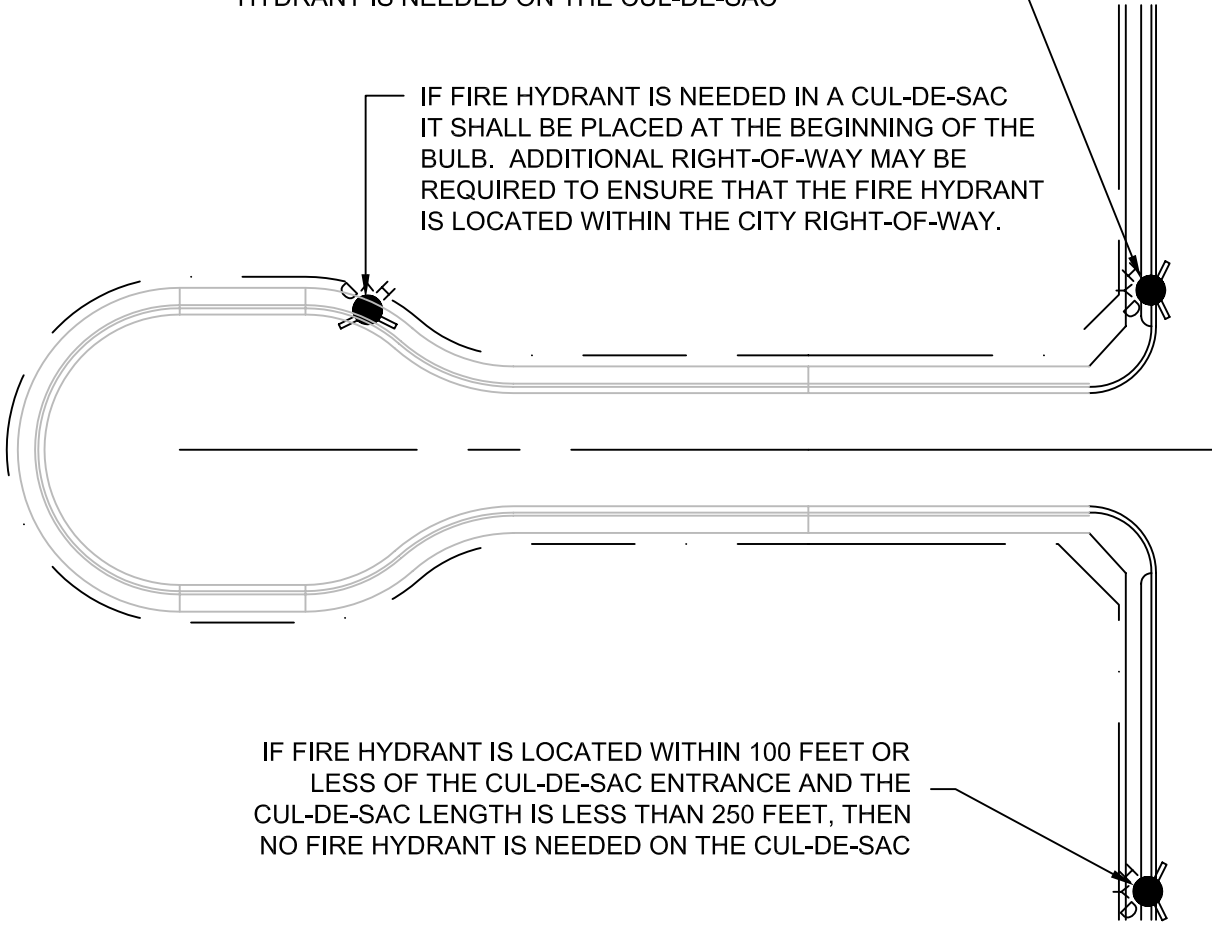

IF FIRE HYDRANT IS LOCATED WITHIN 100 FEET OR LESS OF THE CUL-DE-SAC ENTRANCE AND THE CUL-DE-SAC LENGTH IS LESS THAN 250 FEET, THEN NO FIRE HYDRANT IS NEEDED ON THE CUL-DE-SAC

**FIRE HYDRANT LOCATIONS FOR CUL-DE-SAC APPLICATIONS**

**NOTES:**

1. FIRE HYDRANTS SHALL BE LOCATED ON ALL REQUIRED ACCESS ROADWAYS AND CITY STREETS ACCORDING TO THE FOLLOWING MINIMUM REQUIREMENTS.
  - A) 300 FEET ON CENTER FOR ALL COMMERCIAL/INDUSTRIAL PROPERTIES.
  - B) 350 FEET ON CENTER FOR GROUP R-3 OCCUPANCIES AS DEFINED IN THE U.B.C.
  - C) 400 FEET ON CENTER FOR GROUP R-1 OCCUPANCIES AS DEFINED IN THE U.B.C.

NO.	REVISED	BY	<b>Fire Hydrant Spacing</b>	APPROVED	 CITY ENGINEER RCE-28191
				DATE: 2-2-99	
DRAWN BY: MCP			<b>CITY OF RIPON</b>	STANDARD NO. <b>W-21</b>	
CHECKED BY: DJR					
V:\125_City of Ripon Standards\Standard Specifications\Drawings\Water\W-21.dwg					

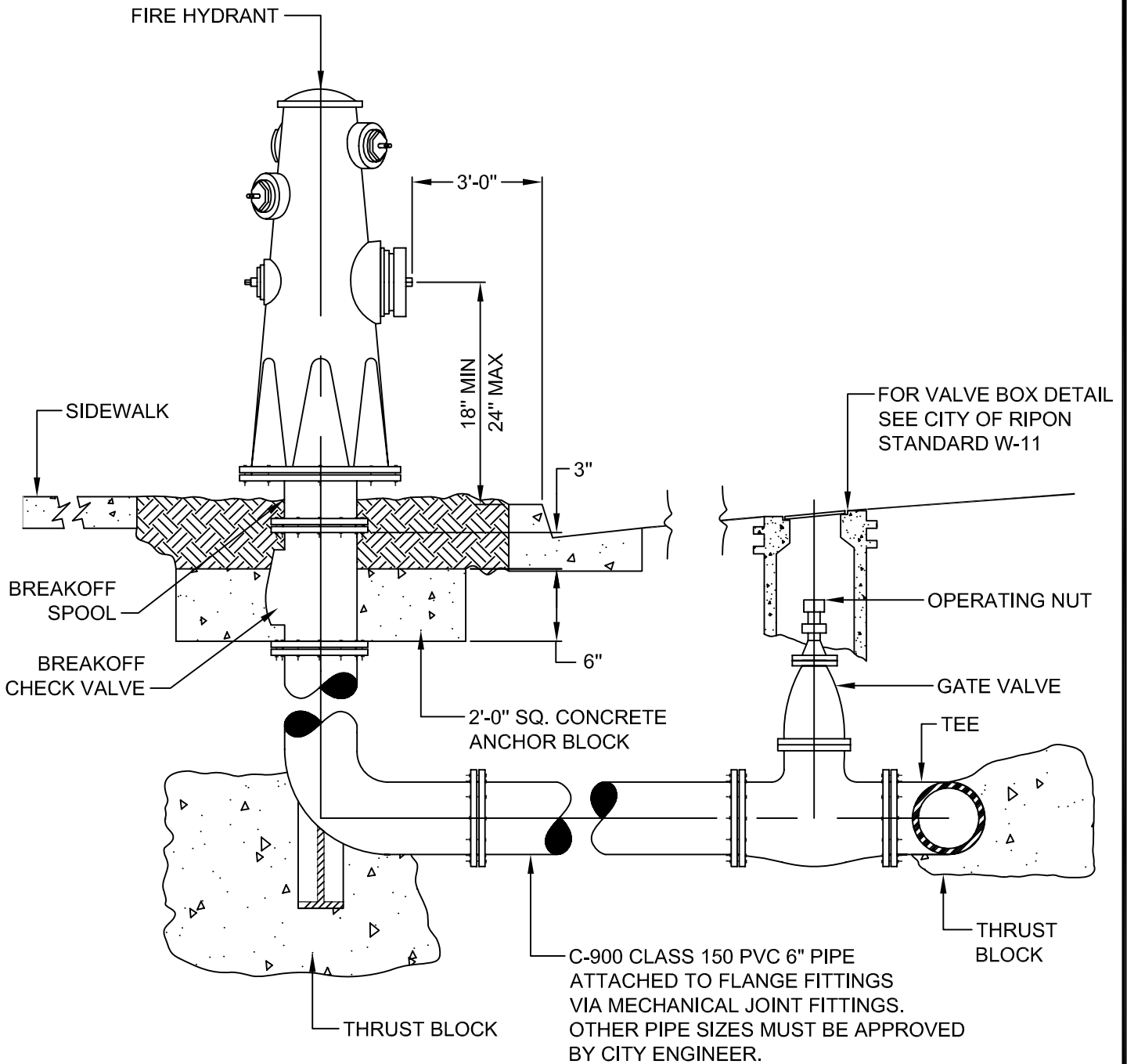

FOR HYDRANT NOTES AND SPECIFICATIONS SEE CITY OF RIPON STANDARD W-22A.

NO.	REVISED	BY	<b>Fire Hydrant at Back of Curb in Parkway Planter</b>	APPROVED
				 CITY ENGINEER 58093
DRAWN BY: MCP				DATE: 11-7-00
CHECKED BY: DJR				STANDARD NO. <b>W-22</b>
V:\125_City of Ripon Standards\Standard Specifications\Drawings\Water\W-22.dwg				<b>CITY OF RIPON</b>

## FIRE HYDRANT NOTES:

THE FOLLOWING REQUIREMENTS MUST BE MET FOR ANY FIRE HYDRANT WHICH WILL:

- A. RECEIVE IT'S SUPPLY OF WATER FROM THE CITY OF RIPON WATER SYSTEM AND/OR
- B. BE INSTALLED INSIDE THE RIPON CONSOLIDATED FIRE DISTRICT BOUNDARIES.

ALL FIRE HYDRANTS, BY DESIGN AND INSTALLATION, SHALL:

1. BE EQUIPPED WITH TWO (2) - 2-1/2" OUTLETS, ONE (1) - 4-1/2" OUTLET AND A 6" MOUNTING FLANGE.
  - A. EACH OUTLET WILL BE CONTROLLED BY A SEPARATE VALVE
  - B. ALL OUTLETS WILL BE EQUIPPED WITH RIGHT HAND NATIONAL STANDARD THREAD.
2. BE PLACED WITH THE 4-1/2" OUTLET FACING THE STREET.
3. HAVE 3' CLEARANCE, FROM CENTER OF FIRE HYDRANT, FROM ANY OBSTRUCTION, ON ALL SIDES.
4. BE PAINTED WITH TWO (2) COATS OF LONG BEACH IRON WORKS YELLOW OR LIGHT (SAFETY) YELLOW (ELLIS-HILUX 1145-245 OR EQUIVALENT), ANY OTHER PAINT SHADES SHALL BE APPROVED BY THE FIRE CHIEF.
5. BE FUSION BONDED EPOXY LINED (INTERIOR OF HYDRANT) WITH 3M SCOTCH-KOTE 302 OR EQUIVALENT (MINIMUM OF 8 MILS THICKNESS).
6. APPROVED FIRE HYDRANTS ARE AS FOLLOWS:
  - A. LONG BEACH IRON WORKS, MODEL # 960
  - B. ALL OTHERS TO BE APPROVED BY THE RIPON FIRE CHIEF.
7. APPROVED BREAK-OFF CHECK VALVES ARE AS FOLLOWS:
  - A. LONG BEACH IRON WORKS, MODEL # LB400
  - B. ALL OTHERS TO BE APPROVED BY THE RIPON FIRE CHIEF.

## STREET MARKING NOTES:

THE FOLLOWING REQUIREMENTS MUST BE MET WHEN INSTALLING ANY STREET MARKER WHICH IS USED TO IDENTIFY THE LOCATION OF ANY FIRE HYDRANT THAT IS PLACED FOR SERVICE WITHIN RIPON CONSOLIDATED FIRE DISTRICT BOUNDARIES.

ALL STREET MARKERS, BY DESIGN AND INSTALLATION SHALL:

1. BE PLACED DIRECTLY ADJACENT TO THE FIRE HYDRANT WHICH THEY WILL IDENTIFY.
2. BE PLACED 12" FROM THE CENTER LINE OF THE ROADWAY TOWARD THE SIDE OF THE ROAD ON WHICH THE FIRE HYDRANT IS LOCATED.
3. BE PLACED TO ALLOW EASY IDENTIFICATION BY ONCOMING TRAFFIC FROM EITHER DIRECTION OF TRAVEL ON THE ROADWAY TO WHICH THEY ARE AFFIXED.
4. BE AFFIXED TO THE ROADWAY ACCORDING TO MANUFACTURER'S INSTRUCTIONS USING AN EPOXY ADHESIVE WHICH HAS BEEN APPROVED BY THE MANUFACTURER.
5. BE MADE OF REFLECTIVE TYPE MATERIAL.
6. BE BLUE IN COLOR.
7. APPROVED STREET MARKERS ARE AS FOLLOWS:
  - A. DISPENSING TECHNOLOGY CORP. MODEL # RPS-1005/B
  - B. ALL OTHERS TO BE APPROVED BY THE RIPON FIRE CHIEF

NO.	REVISED	BY	<b>Fire Hydrant Notes</b>	APPROVED 
				CITY ENGINEER 58093
				DATE: 11-7-00
DRAWN BY: KWZ				<b>CITY OF RIPON</b>
CHECKED BY: DJR				
V:\25_City of Ripon Standards\Standard Specifications\Drawings\Water\W-22a.dwg				

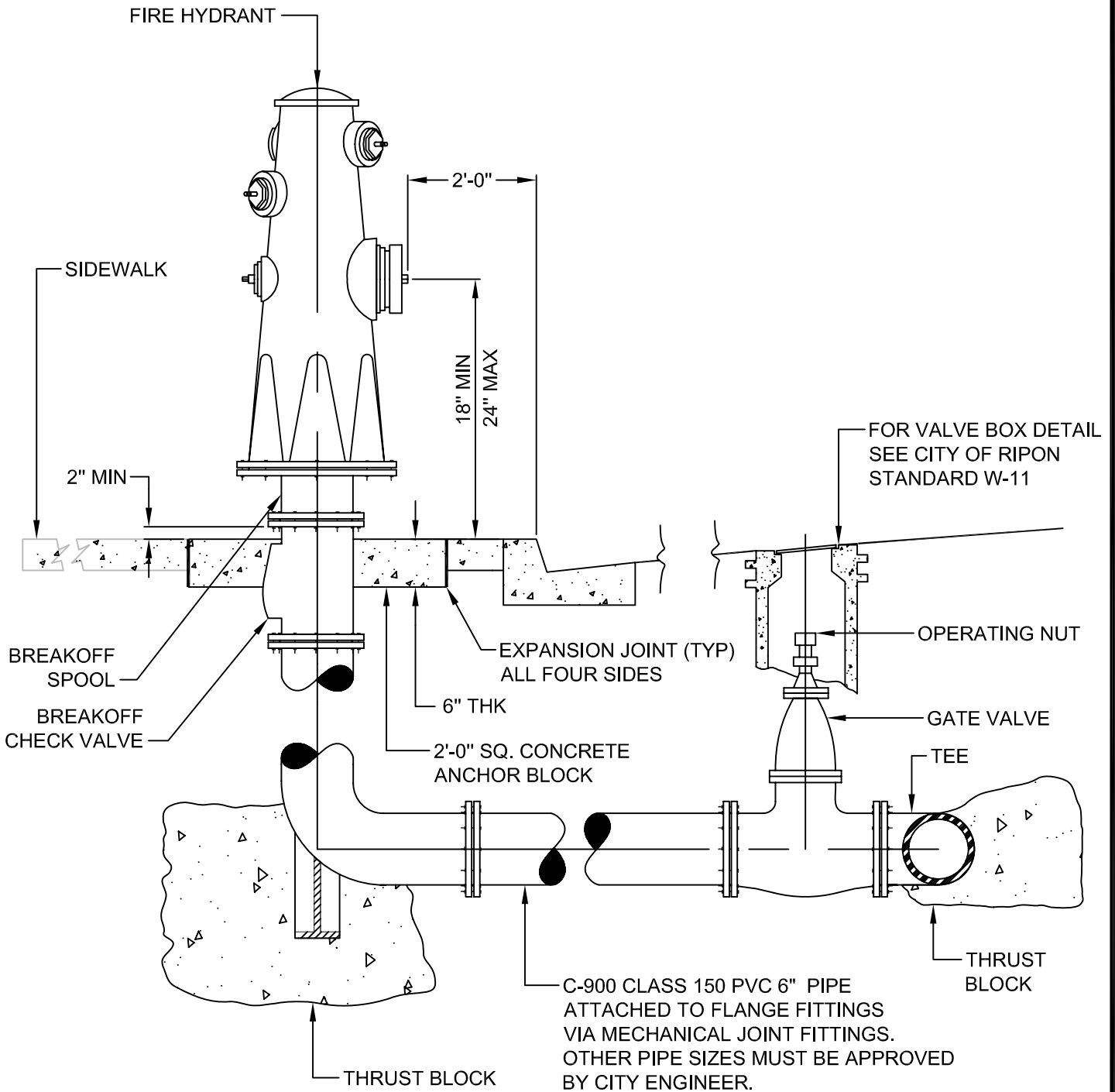

**NOTES:**

1. FOR HYDRANT NOTES AND SPECIFICATIONS SEE CITY OF RIPON STANDARD W-22A.
2. MUST MAINTAIN FOUR (4) FEET OF CLEARANCE AROUND BACK SIDE OF FIRE HYDRANT FOR A.D.A. COMPLIANCE.

NO.	REVISED	BY	<p><b>Fire Hydrant with Vertical Curb and Attached Sidewalk</b></p> <p><b>CITY OF RIPON</b></p>	APPROVED	 CITY ENGINEER 58093
				DATE: 11-7-00	
DRAWN BY: MCP				STANDARD NO. <b>W-23</b>	
CHECKED BY: DJR					
<small>V:\125_City of Ripon Standards\Standard Specifications\Drawings\Water\W-23.dwg</small>					

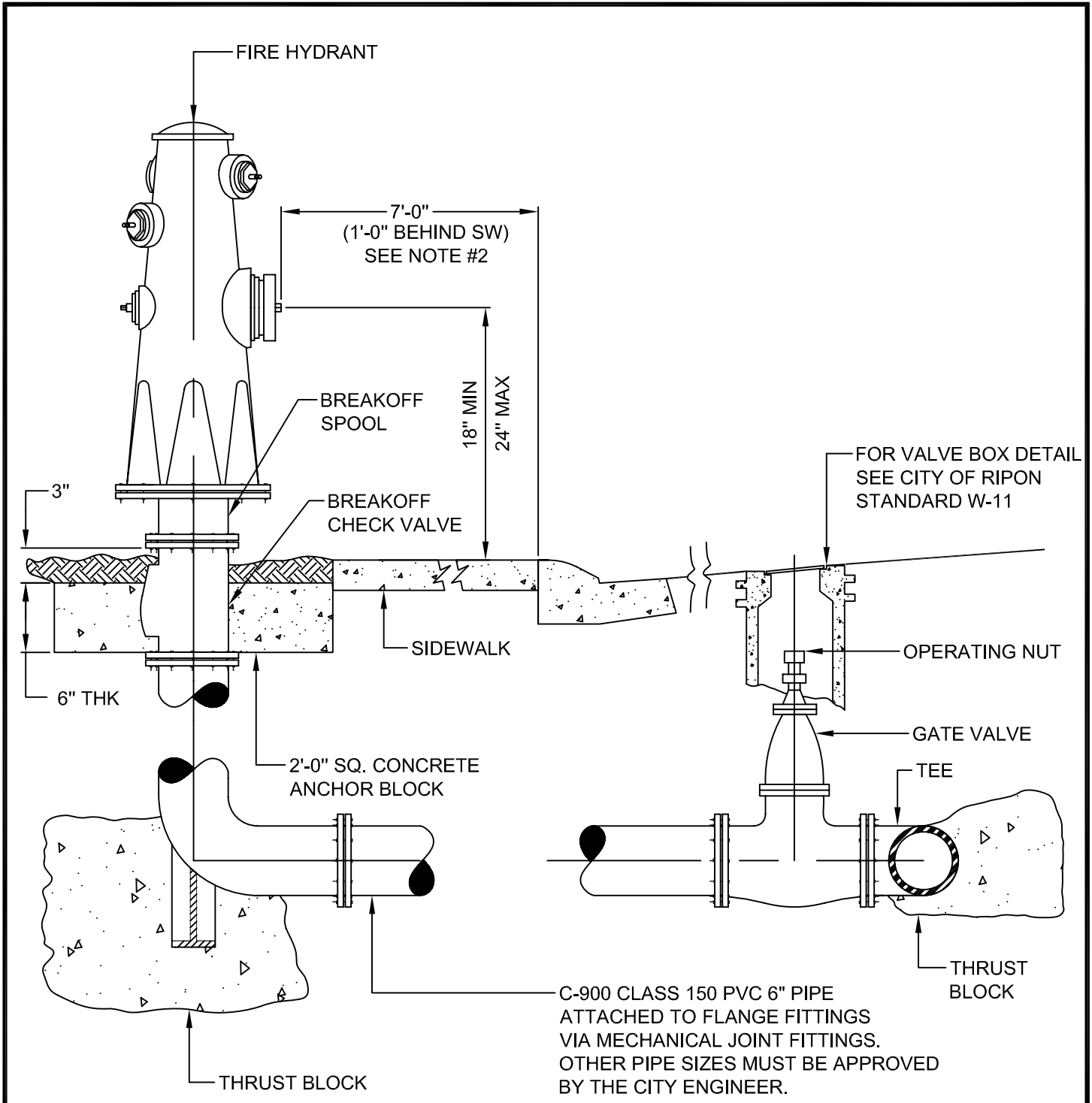

**NOTES:**

- 1. FOR HYDRANT NOTES AND SPECIFICATIONS SEE CITY OF RIPON STANDARD W-22A.
- 2. FIRE HYDRANT SHALL BE PLACED AT 1'-0" BEHIND SIDEWALK, ADDITIONAL RIGHT-OF-WAY MAY NEED TO BE PROVIDED FOR THIS HYDRANT INSTALLATION.

NO.	REVISED	BY	<p><b>Fire Hydrant with Drive-Over Curb and Attached Sidewalk</b></p>	APPROVED	 CITY ENGINEER 58093
DRAWN BY: MCP				DATE: 11-7-00	
CHECKED BY: DJR			<p><b>CITY OF RIPON</b></p>	<p>STANDARD NO. <b>W-23a</b></p>	
V:\25_City of Ripon Standards\Standard Specifications\Drawings\Water\W-23A.dwg					



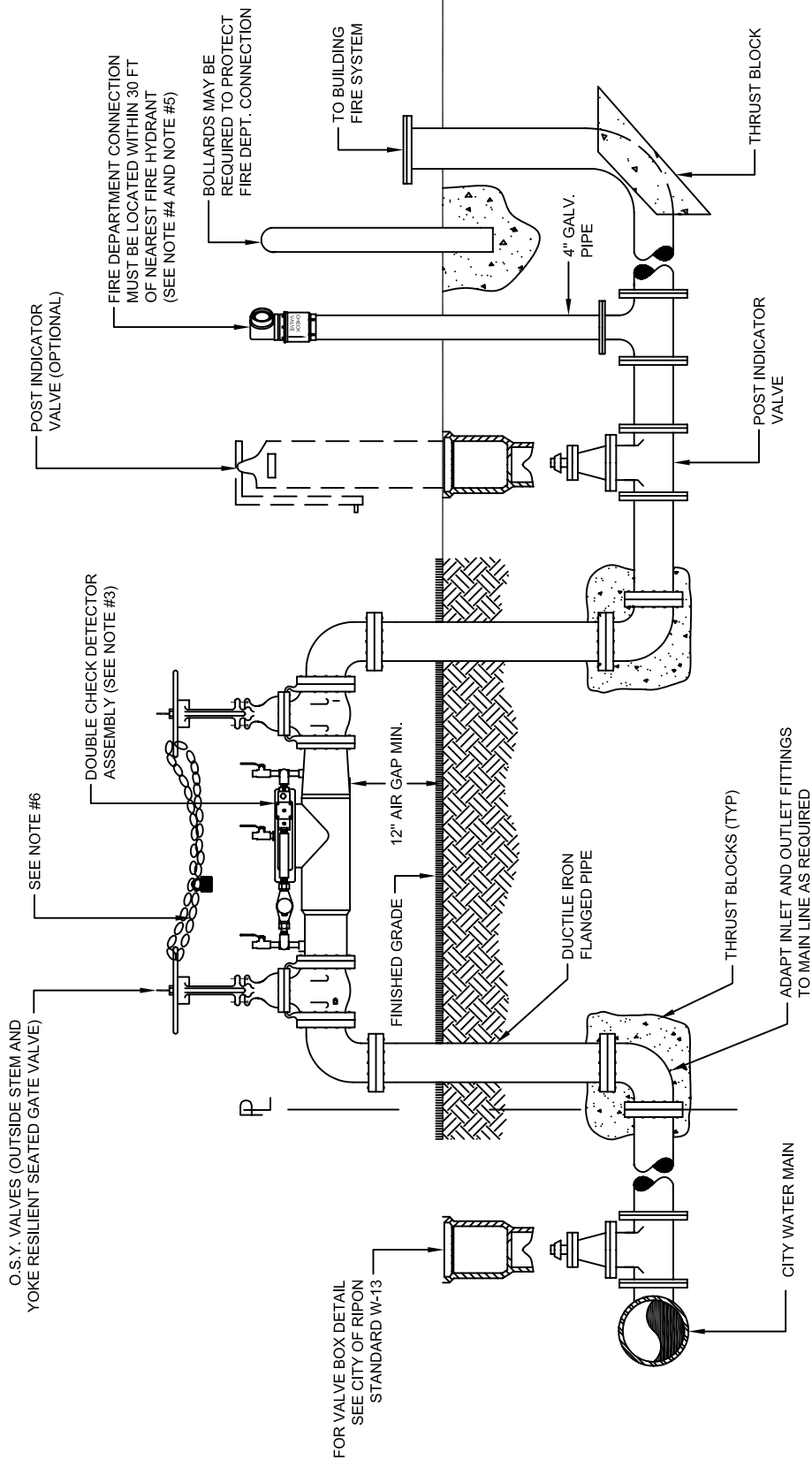

**NOTES:**

1. INSTALL A 12" AIR GAP MINIMUM BETWEEN FINISHED GRADE AND DOUBLE CHECK DETECTOR ASSEMBLY.
2. ALL CONNECTIONS ON ASSEMBLY SHALL BE FLANGED FITTINGS.
3. DOUBLE CHECK DETECTOR ASSEMBLY SHALL BE AN APPROVED DEVICE BY THE STATE OF CALIFORNIA DEPARTMENT OF HEALTH SERVICES. (SOME APPROVED EXAMPLES INCLUDE: AMES 3000SS, FEBCO 876, WILKINS 3500DA, ETC.)
4. FIRE DEPARTMENT CONNECTION MUST BE LOCATED WITHIN 30 FEET OF A FIRE HYDRANT.
5. FIRE DEPARTMENT CONNECTION MUST INCLUDE THE FOLLOWING:
  - A. ONE INLINE CHECK VALVE (KIDDE FIRE MODEL #202) OR APPROVED EQUAL.
  - B. ONE FIRE DEPARTMENT CONNECTION (PART # ASC 9181 - 90 DEGREE PATTERN, TWO 2-1/2" NST FEMALE INLET WITH A 4" NPT THREAD FEMALE OUTLET), OR APPROVED EQUAL.
  - C. LOCKING COVERS FOR FIRE DEPARTMENTS CONNECTION (KNOX FDC CAP MODEL # 3010 OR # 3011), OR APPROVED EQUAL. KNOX FDC CAP KEYS SHALL BE TURNED OVER TO THE FIRE DEPARTMENT UPON FIRE SYSTEM APPROVAL.
6. ONCE SYSTEM IS INSTALLED AND FUNCTIONING THE GATE VALVES SHOULD BE CHAINED AND LOCKED OPEN.

NO.	REVISED	BY
DRAWN BY: MATT		
CHECKED BY: DJR		
V:\25_City of Ripon Standards\Standard Specifications\Drawings\Water\W-24.dwg		

**Fire Sprinkler Connection  
Located More Than 30 Feet  
from Nearest Fire Hydrant**

**CITY OF RIPON**

APPROVED

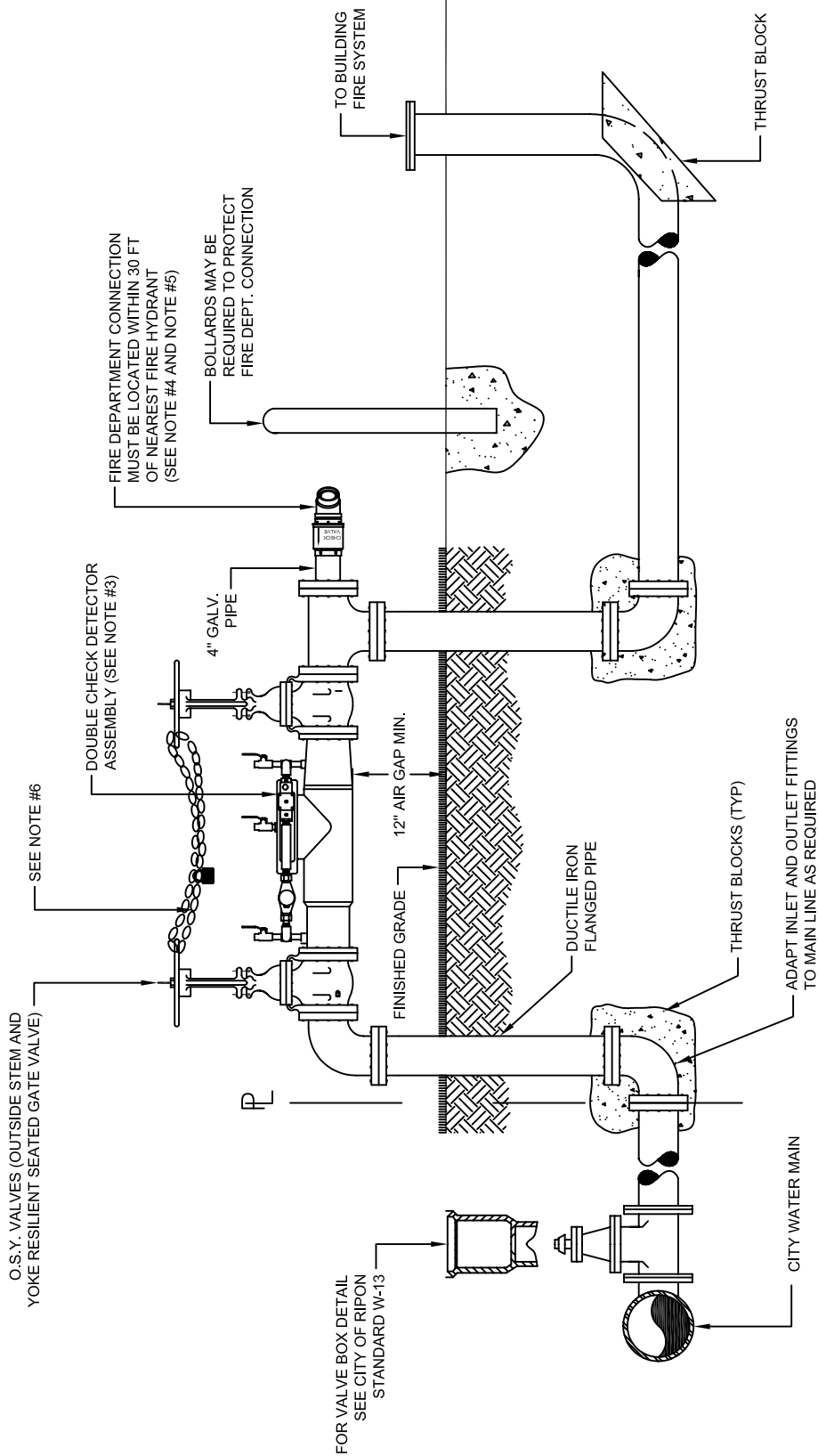
CITY ENGINEER RCE-28191
DATE: 2-2-99
STANDARD NO. <b>W-24</b>



**NOTES:**

1. INSTALL A 12" AIR GAP MINIMUM BETWEEN FINISHED GRADE AND DOUBLE CHECK DETECTOR ASSEMBLY.
2. ALL CONNECTIONS ON ASSEMBLY SHALL BE FLANGED FITTINGS.
3. DOUBLE CHECK DETECTOR ASSEMBLY SHALL BE AN APPROVED DEVICE BY THE STATE OF CALIFORNIA DEPARTMENT OF HEALTH SERVICES. (SOME APPROVED EXAMPLES INCLUDE: AMES 3000SS, FEBCO 876, WILKINS 3500DA, ETC.)
4. FIRE DEPARTMENT CONNECTION MUST BE LOCATED WITHIN 30 FEET OF A FIRE HYDRANT.
5. FIRE DEPARTMENT CONNECTION MUST INCLUDE THE FOLLOWING:
  - A. ONE INLINE CHECK VALVE (KIDDE FIRE MODEL #202) OR APPROVED EQUAL.
  - B. ONE FIRE DEPARTMENT CONNECTION (PART # ASC 9181 - 90 DEGREE PATTERN, TWO 2-1/2" NST FEMALE INLET WITH A 4" NPT THREAD FEMALE OUTLET), OR APPROVED EQUAL.
  - C. LOCKING COVERS FOR FIRE DEPARTMENTS CONNECTION (KNOX FDC CAP MODEL # 3010 OR # 3011), OR APPROVED EQUAL. KNOX FDC CAP KEYS SHALL BE TURNED OVER TO THE FIRE DEPARTMENT UPON FIRE SYSTEM APPROVAL.
6. ONCE SYSTEM IS INSTALLED AND FUNCTIONING THE GATE VALVES SHOULD BE CHAINED AND LOCKED OPEN.

NO.	REVISED	BY
DRAWN BY: MATT		
CHECKED BY: DJR		
V:\25_City of Ripon Standards\Standard Specifications\Drawings\Water\W-25.dwg		

**Fire Sprinkler Connection  
Located within 30 Feet  
from Nearest Fire Hydrant**

**CITY OF RIPON**

APPROVED

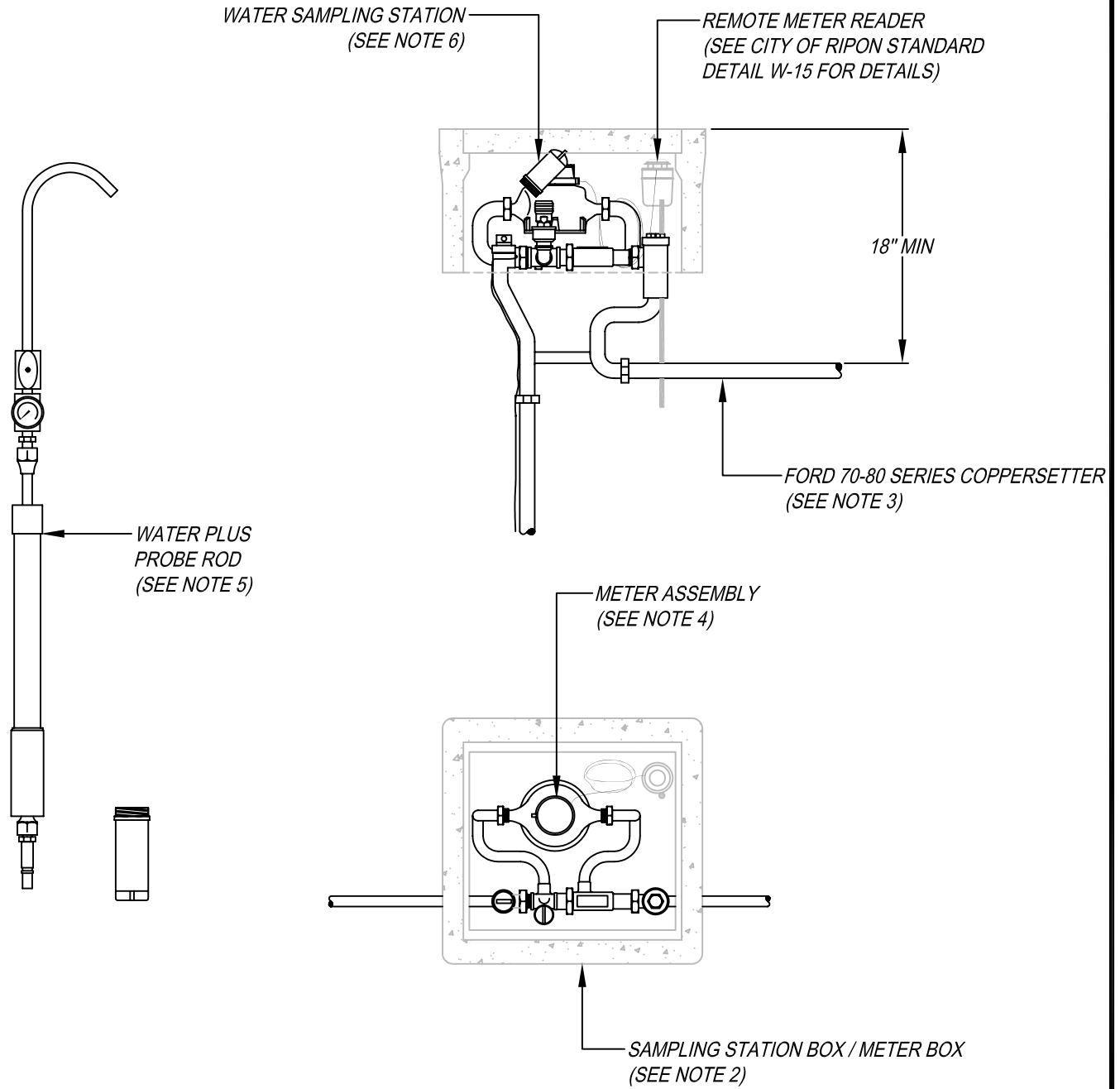
CITY ENGINEER RCE-28191
DATE: 2-2-99
STANDARD NO. <b>W-25</b>



**NOTES:**

1. SAMPLING STATION BOX / METER BOX TO BE INSTALLED PER CITY OF RIPON STANDARD W-14.
2. METER BOX SHALL BE CHRISTY NO. B-24 OR APPROVED EQUAL. BOXES IN TRAFFIC AREAS SHALL HAVE TRAFFIC RATED COVERS. ALL COVERS SHALL HAVE A METER READING LID, A CHRISTY B24g IN NON-TRAFFIC AREAS AND A CHRISTY B24-61g IN TRAFFIC AREAS.
3. WATER SAMPLING STATION SHALL BE SET USING A FORD 70-80 SERIES COPPERSETTER (PART NO. VBH-74-84-11-44 WITH C86-44 ADAPTER).
4. WATER METER SHALL BE A BADGER RECORDALL 1" DISK METER, PART NO. RCDL 70.
5. ALL SAMPLING STATIONS SHALL BE PROVIDED AND INSTALLED BY THE DEVELOPER AND/OR CONTRACTOR. A WATER PLUS PROBE ROD (PART NO. 150G) SHALL BE PROVIDED TO THE CITY OF RIPON FOR EVERY SAMPLING STATION REQUIRED.
6. WATER SAMPLING STATION SHALL BE A WATER PLUS ALL-IN-ONE SAMPLE STATION (MODEL #15001034).
7. SAMPLING STATIONS SHALL BE PLACED WITHIN SUBDIVISIONS AS DETERMINED BY THE CITY OF RIPON.

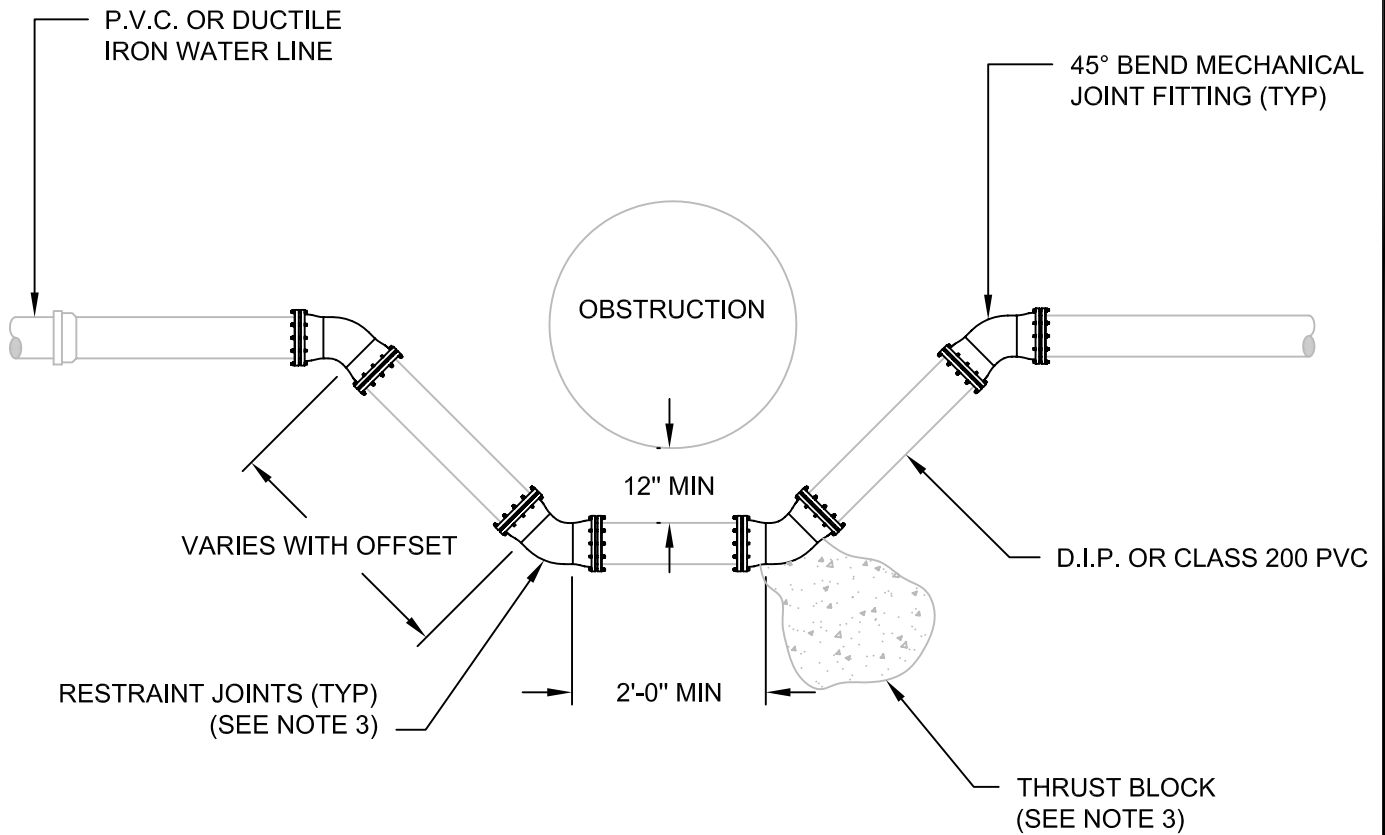
NO.	REVISED	BY	<b>Water Sampling Station Detail</b>	APPROVED	<i>[Signature]</i> CITY ENGINEER RCE-28191
				DATE: 2-2-99	
DRAWN BY: MCP				<b>CITY OF RIPON</b>	
CHECKED BY: DJR					
V: 125_City of Ripon Standards \ Standard Specifications \ Drawings \ Water \ W-26.dwg					



**NOTES:**

1. ALL MATERIALS AND COATINGS TO BE IN ACCORDANCE WITH SPECIFICATIONS FOR WATER MAIN CONSTRUCTION AND MATERIALS.
2. INSULATED JOINT TO BE MADE UP USING INSULATING GASKETS, PLASTIC BOLT SLEEVES AND WASHERS FOR INSULATING GASKET MATERIAL TO BE BACKED WITH CAD-PLATED WASHERS, OR OTHER METHODS APPROVED BY THE CITY ENGINEER.
3. THRUST BLOCKS MAY BE USED WITH MECHANICAL JOINT FITTINGS ON THE BOTTOM 45° BEND FITTINGS, IN PLACE OF THE RESTRAINT JOINT FITTINGS. THRUST BLOCKS SHALL BE INSTALLED PER CITY OF RIPON STANDARD W-12. RESTRAINT JOINT FITTINGS MUST BE USED ON THE TOP 45° BEND FITTINGS.

NO.	REVISED	BY	<b>Typical Offset Unit</b>	APPROVED	
				CITY ENGINEER RCE-28191	
				DATE: 2-2-99	
DRAWN BY: TP			<b>CITY OF RIPON</b>	STANDARD NO. <b>W-27</b>	
CHECKED BY: DJR					
V:\125_City of Ripon Standards\Standard Specifications\Drawings\Water\w-27.dwg					

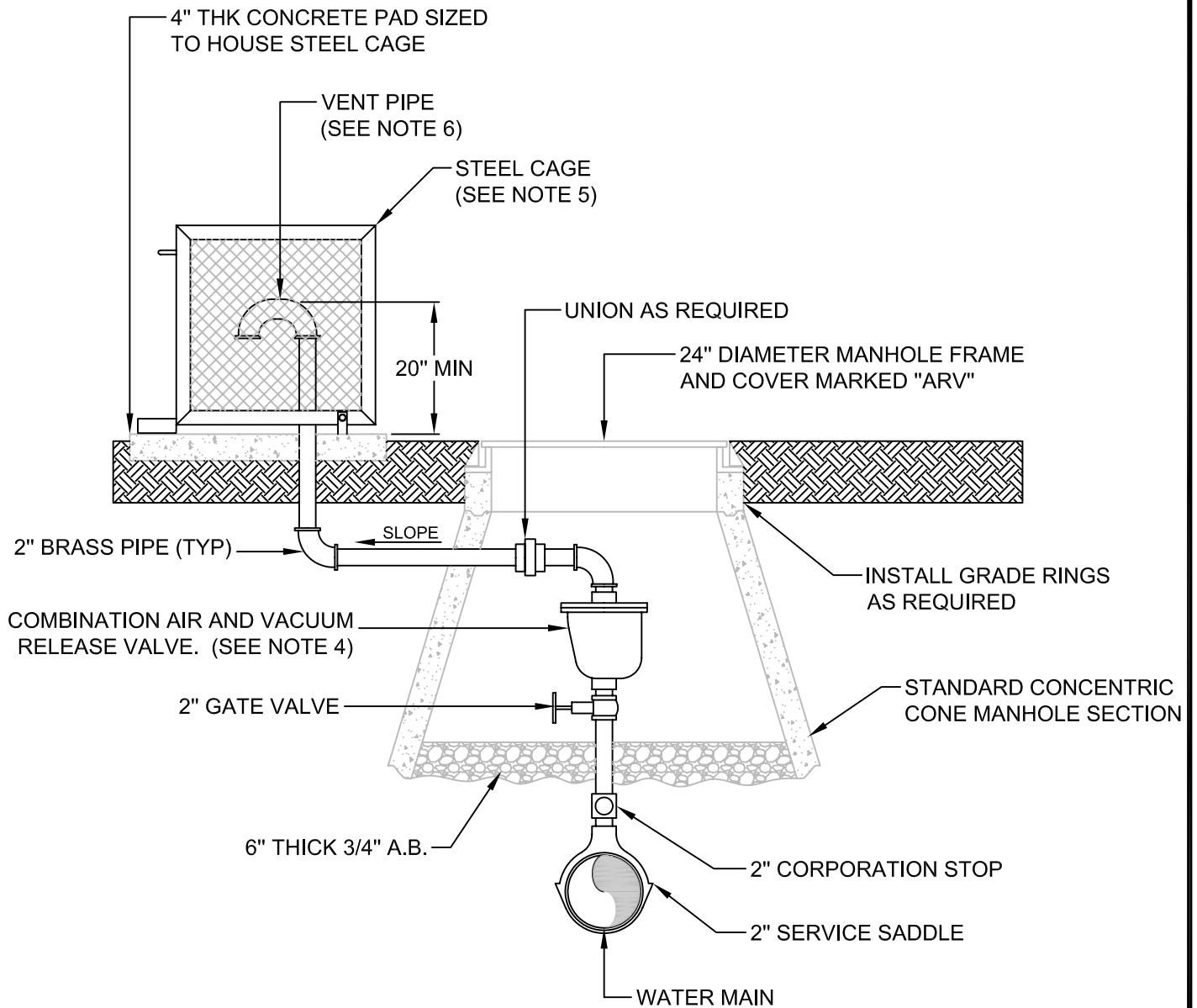

**NOTES:**

1. LOCATE AIR AND VACUUM RELEASE VALVE AT ALL INTERMEDIATE HIGH POINTS IN LINE AND AS CALLED FOR ON PLANS.
2. ALL FITTINGS AND PIPING SHALL BE BRASS. SERVICE SADDLE SHALL BE DOUBLE STRAP BRASS (FORD S90, JAMES JONES J996, OR APPROVED EQUAL).
3. PLACE VENT AT BACK OF CURB IN PARKWAY OR AT BACK OF WALK WITHIN THE CITY RIGHT-OF-WAY.
4. COMBINATION AIR AND VACUUM RELEASE VALVE SHALL BE APCO 143C SERIES, CRISPIN U10 SERIES, VALMATIC 201C, OR APPROVED EQUAL.
5. STEEL CAGE TO BE 24" HIGH x 24" LONG x 12" WIDE. APPROVED CAGE VENDOR: LE MEUR WELDING AND MANUFACTURING (877) 453-6387 OR APPROVED EQUAL.
6. 180° BRASS RETURN ELBOW WITH SCREEN ATTACHED ATTACHED TO THE END.

NO.	REVISED	BY	<b>Air and Vacuum Release Valve Detail</b>	APPROVED	 CITY ENGINEER 58093
				DATE: 11-7-00	
				STANDARD NO. <b>W-28</b>	
DRAWN BY: KWZ			<b>CITY OF RIPON</b>		
CHECKED BY:					
V:\125_City of Ripon Standards\Standard Specifications\Drawings\Water\W-28.dwg					

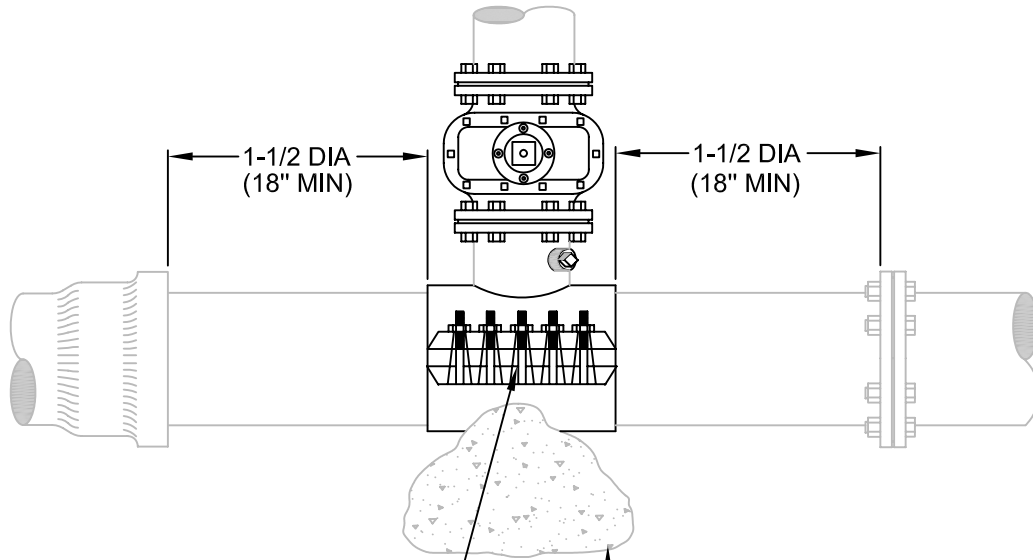

TAPPING SLEEVE - ROMAC STT STAINLESS STEEL, OR APPROVED EQUAL (SEE NOTE 2)

THRUST BLOCK PER CITY OF RIPON STANDARD W-12

**NOTES:**

1. NEW LINE AND TAPPING SLEEVE MUST BE AT LEAST ONE SIZE SMALLER THAN THE EXISTING WATER MAIN.
2. TAPPING SLEEVE SHALL BE SEPARATED FROM NEAREST BELL, FLANGE, SERVICE CLAMP, CORP STOP, ETC. BY A DISTANCE NO LESS THEN 1-1/2 TIMES THE PIPE DIAMETER, WITH A MINIMUM SEPARATION OF 18".

NO.	REVISED	BY	<b>Waterline Hot Tap Detail</b>	APPROVED	
				CITY ENGINEER	58093
DRAWN BY: KWZ				DATE:	11-7-00
CHECKED BY:			<b>CITY OF RIPON</b>	STANDARD NO.	<b>W-29</b>
<small>V:\125_City of Ripon Standards\Standard Specifications\Drawings\Water\W-29.dwg</small>					

THIS PAGE  
INTENTIONALLY LEFT BLANK

NO.	REVISED	BY	APPROVED
			
			CITY ENGINEER 58093
DRAWN BY: KWZ			DATE: 11-7-00
CHECKED BY:			STANDARD NO. <b>W-30</b>
V:\125_City of Ripon Standards\Standard Specifications\Drawings\Water\W-30.dwg			
<b>CITY OF RIPON</b>			

1. Storm drain design shall be in conformance with the City of Ripon's current storm drainage master plan.
2. Minimum gutter slope 0.0033 ft/ft.
3. Minimum gutter slope around radius corner 0.0065 ft/ft.
4. Off-street parking area surface drainage: Minimum cross-slope on asphalt concrete 2%, Minimum cross-slope on concrete 0.5%, Maximum cross-slope on asphalt concrete and concrete 5%.
5. Catch basins shall connect by laterals to manhole only.
6. Access to storm drain pipe shall be provided by a manhole at intervals of 400 feet on lines 18 inches or smaller and 600 feet on lines greater than 18 inches.
7. Manholes shall be provided at all junctions and changes of alignment, grade, or size of pipe.
8. Lines shall be placed through the manhole.
9. Storm drain mains shall be a minimum of 15 inches.
10. Valley gutters will not be permitted for street drainage.
11. Inverted siphons will not be permitted for street drainage.
12. The use of dry wells for disposal of runoff will not be permitted.
13. Controlling factors: maximum encroachment of water 10 feet from face of curb.
14. Maximum gutter length, per catch basin, shall not exceed 600 feet.
15. Mannings "n" typical for concrete pipe shall be 0.013.
16. Storm drain mains shall be designed to flow at a minimum of 3.0 feet per second.
17. Storm drain lines shall have a minimum cover of 30 inches.
18. Minimum of 18 inch laterals at a slope of 0.008 ft/ft to connect catch basins to storm manholes.
19. The rational method is to be used for the determination of peak rates of flow for storm water runoff, and shall be used in the design of detention basins.

Q=CIA

Q = the runoff rate in cubic feet per second

C = the coefficient of runoff

I = the average rainfall intensity in inches per hour for a duration equal to the time of concentration

A = the size of the tributary drainage area in acres

20. Runoff coefficients for the City of Ripon

<u>Land Use Type</u>	<u>C</u>	<u>Minimum Overland Flow Time in Minutes</u> <u>(Mild Slope)</u>
Industrial	0.90	10
Commercial	0.75	15
Professional	0.75	15
Administrative	0.75	15
Multi-family Residential	0.45	20
Single family Residential	0.40	25
Schools	0.25	25
Parks and Agricultural	0.10	30

NO.	REVISED	BY	<b>Criteria for Design of Storm Drain Facilities</b>	APPROVED
				
				CITY ENGINEER RCE-28191
				DATE: 2-2-99
DRAWN BY: Matt			<b>CITY OF RIPON</b>	STANDARD NO. <b>SD-1</b>
CHECKED BY: DJR				
V:\25_City of Ripon Standards\Standard Specifications\Drawings\Storm\SD-1.dwg				



(Continued from 20) Basic runoff coefficients:

<u>Surface Type</u>	<u>C</u>
Pavement	0.95
Roofs	0.95
Compacted Earth or Gravel	0.75
Lawns and Open Areas	0.15

21. Design frequency based on 10 year 48 hour storm event.
22. The storm drain retention basin volume shall be determined by the following formula:

$$V = (CAR)/12$$

V = the basin volume in acre feet

C = the runoff coefficient (see coefficients for City of Ripon)

A = the contributing area in acres

R = total rainfall in inches for the storm period is as follows: urbanized area 3.56 inches

23. Retention basin outlet, either by gravity or pump, shall empty the basin over a 24 hour period.
24. The volume of retention basins shall be determined with no allowance for percolation or outlet facilities. If desired the developer may conduct a percolation test and storm drain analysis for approval by the City Engineer.
25. When storm drain requires a lift station other than for detention basin, it shall be designed for a 100 year storm.
26. Drain basins shall have a maximum side slope of 10:1 (horizontal to vertical) slope. Steeper slopes must be approved by the City Engineer.
27. Bottom elevation shall be a minimum of five (5) feet above the historical water table average.
28. Maximum depth of basin shall be approved by the City Engineer.
29. The high water elevation of the drainage basin shall be one (1) foot below the hydraulic grade line.
30. Upon completion of all testing and after streets are paved, the contractor shall clean the storm drain. All foreign matter and debris shall be removed, and disposed of in a manner acceptable to the City Engineer.
31. A sprinkler irrigation system shall be designed for and installed in the drain basin. The design shall be approved by the City Engineer. The design shall include a system controller.
32. Basins will be hydro-seeded and maintained for one year by the contractor.
33. Any deviation from these criteria shall have the approval of the City Engineer.

NO.	REVISED	BY	<b>Criteria for Design of Storm Drain Facilities</b>	APPROVED
				 CITY ENGINEER RCE-28191
				DATE: 2-2-99
DRAWN BY: Matt			<b>CITY OF RIPON</b>	STANDARD NO. <b>SD-2</b>
CHECKED BY: DJR				
V:\25_City of Ripon Standards\Standard Specifications\Drawings\Storm\SD-2.dwg				

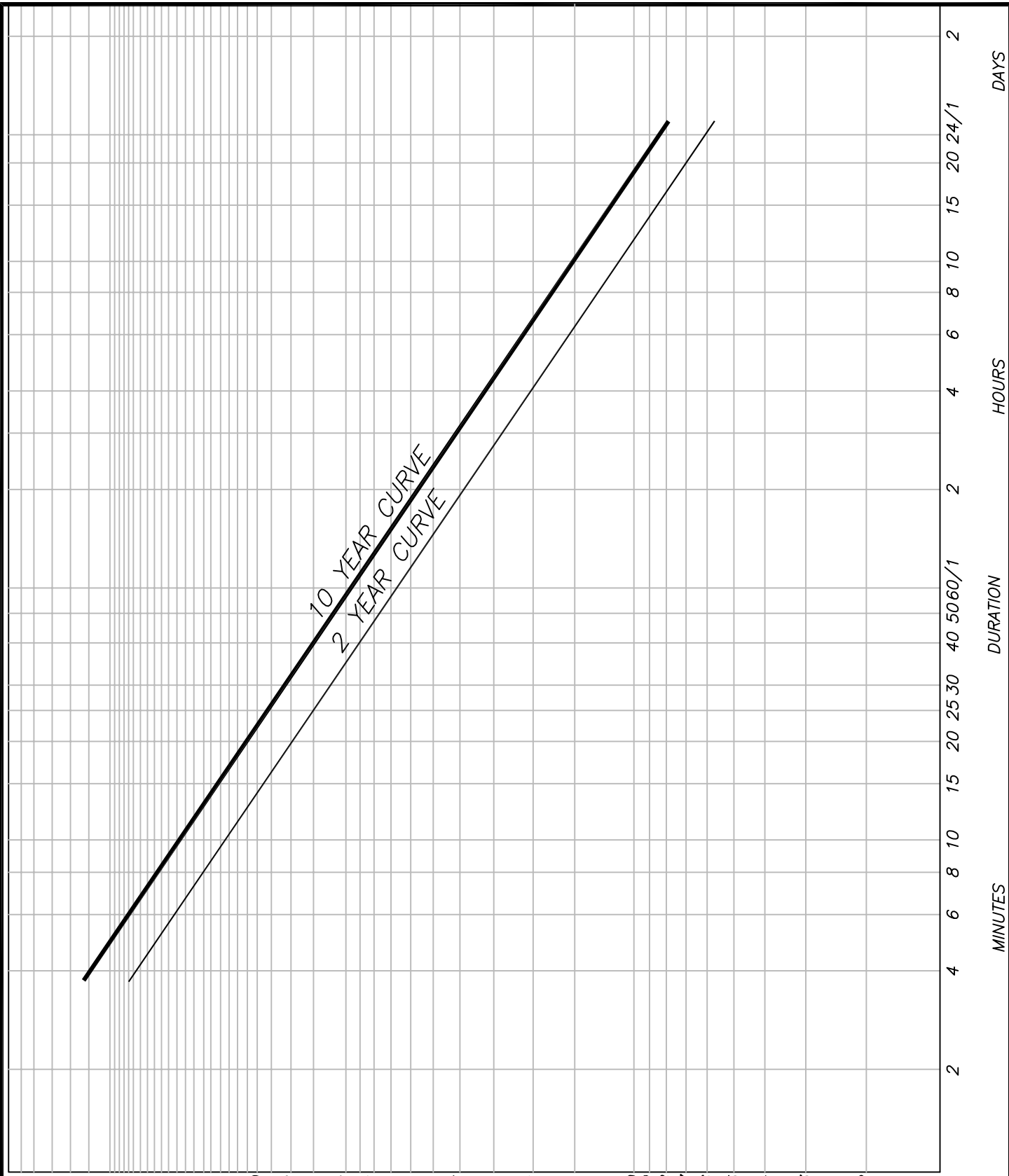

RAINFALL INTENSITY IN INCHES PER HOUR  
 $T_c = \text{TIME OF CONCENTRATION}$   
 10 YR =  $10.1557 / T_c * 0.5638$   
 100 YR =  $6.464 / T_c * 0.5609$

NO.	REVISED	BY
DRAWN BY: TP		
CHECKED BY: DJR		
V:\125_City of Ripon Standards\Standard Specifications\Drawings\Storm\SD-3.dwg		

**Rainfall Intensity Curves**

CITY OF RIPON

APPROVED

*[Signature]*

CITY ENGINEER RCE-28191

DATE: 2-2-99

STANDARD NO. **SD-3**

# RAINFALL INTENSITY CURVE

## 100 YEAR STORM

## 10 YEAR STORM

$$10.1557/T_c^{0.5638}$$

$$6.464/T_c^{0.5609}$$

	Tc (min.)	Intensity (iphr)		Tc (min.)	Intensity (iphr)
	2	6.871		2	4.382
	4	4.648		4	2.97
	6	3.698		6	2.366
LAND USE TYPE	8	3.144	LAND USE TYPE	8	2.014
INDUSTRIAL	10	2.773	INDUSTRIAL	10	1.777
COMMERCIAL	15	2.206	COMMERCIAL	15	1.415
MULTI - FAMILY	20	1.876	MULTI - FAMILY	20	1.204
SINGLE - FAMILY	25	1.654	SINGLE - FAMILY	25	1.063
SCHOOLS	25	1.654	SCHOOLS	25	1.063
PARKS & AGG.	30	1.492	PARKS & AGG.	30	0.959
Tc Hours	40	1.269	Tc Hours	40	0.816
1	60	1.01	1	60	0.65
2	120	0.683	2	120	0.441
3	180	0.543	3	180	0.351
4	240	0.462	4	240	0.299
5	300	0.407	5	300	0.264
6	360	0.368	6	360	0.238
7	420	0.337	7	420	0.218
8	480	0.313	8	480	0.203
9	540	0.293	9	540	0.19
10	600	0.276	10	600	0.179
11	660	0.261	11	660	0.169
12	720	0.249	12	720	0.161
13	780	0.238	13	780	0.154
14	840	0.228	14	840	0.148
15	900	0.219	15	900	0.142
16	960	0.211	16	960	0.137
17	1020	0.204	17	1020	0.133
18	1080	0.198	18	1080	0.129
19	1140	0.192	19	1140	0.125
20	1200	0.186	20	1200	0.121
21	1260	0.181	21	1260	0.118
22	1320	0.177	22	1320	0.115
23	1380	0.172	23	1380	0.112
24 HR / 1 Day	1440	0.168	24 HR / 1 Day	1440	0.109
48 HR / 2 Days	2880	0.114	48 HR / 2 Days	2880	0.074

Tc = Time of Concentration  
iphr = Rainfall Intensity in Inches Per Hour

NO.	REVISED	BY	<h3 style="margin: 0;">Rainfall Intensity Curves</h3>	APPROVED	 CITY ENGINEER RCE-28191	
				DATE: 2-2-99		
DRAWN BY: MCP				<h2 style="margin: 0;">CITY OF RIPON</h2>		STANDARD NO. SD-3a
CHECKED BY: DJR						
V:\25_City of Ripon Standards\Standard Specifications\Drawings\Storm\SD-3a.dwg						

# City of Ripon

## Rainfall Intensity Curve

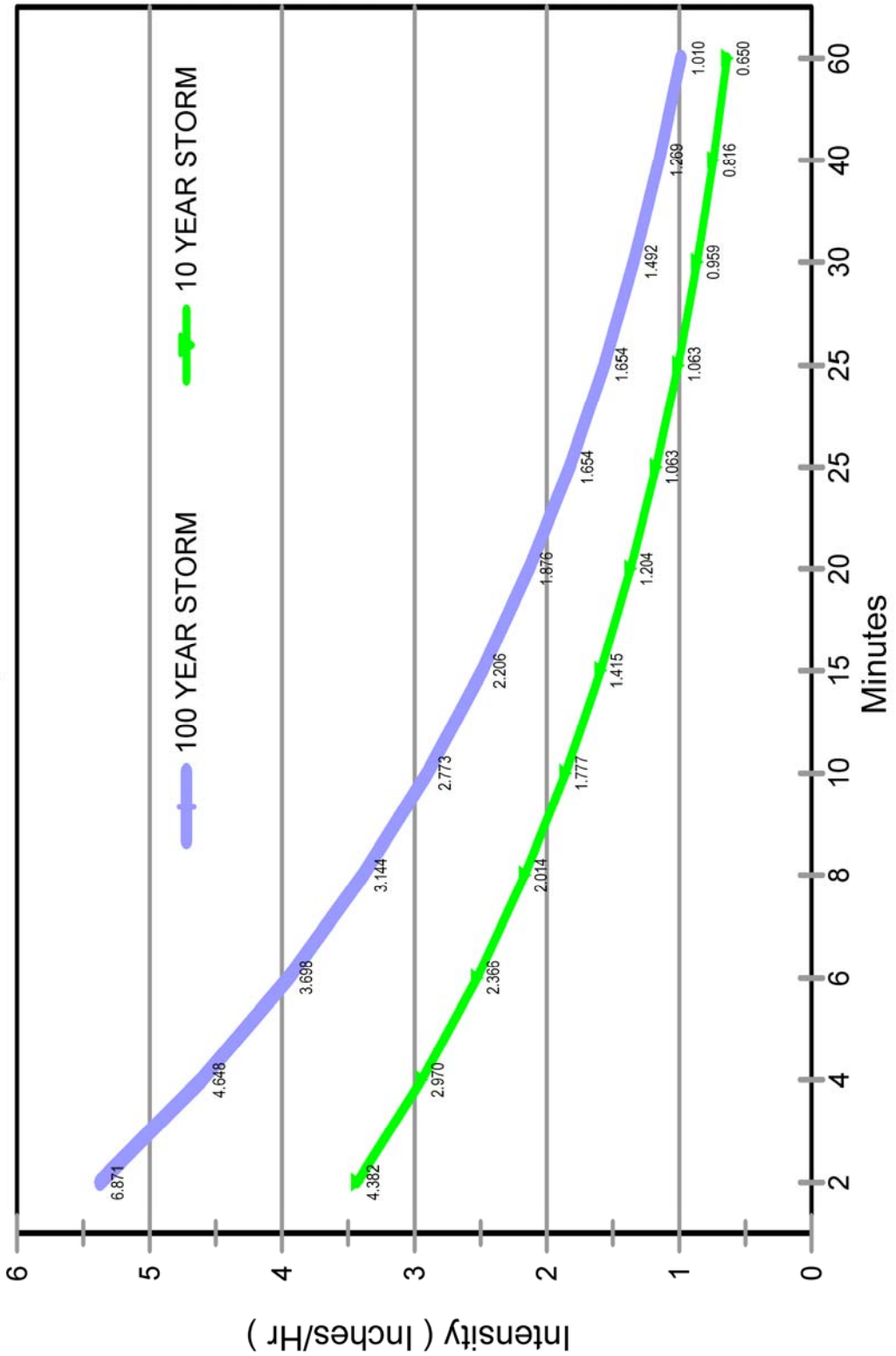

$10 \text{ YR} = 6.464/T_c^{0.5609}$   
 $100 \text{ YR} = 10.1557/T_c^{0.5638}$   
 $T_c = \text{TIME OF CONCENTRATION}$

NO.	REVISED	BY
DRAWN BY: MCP		
CHECKED BY: DJR		
V:\25_City of Ripon Standards\Standard Specifications\Drawings\Storm\SD-3b.dwg		

**Rainfall Intensity Curves**  
**CITY OF RIPON**

APPROVED
<i>[Signature]</i>
CITY ENGINEER RCE-28191
DATE: 2-2-99
STANDARD NO. <b>SD-3b</b>

# City of Ripon

## Rainfall Intensity Curve

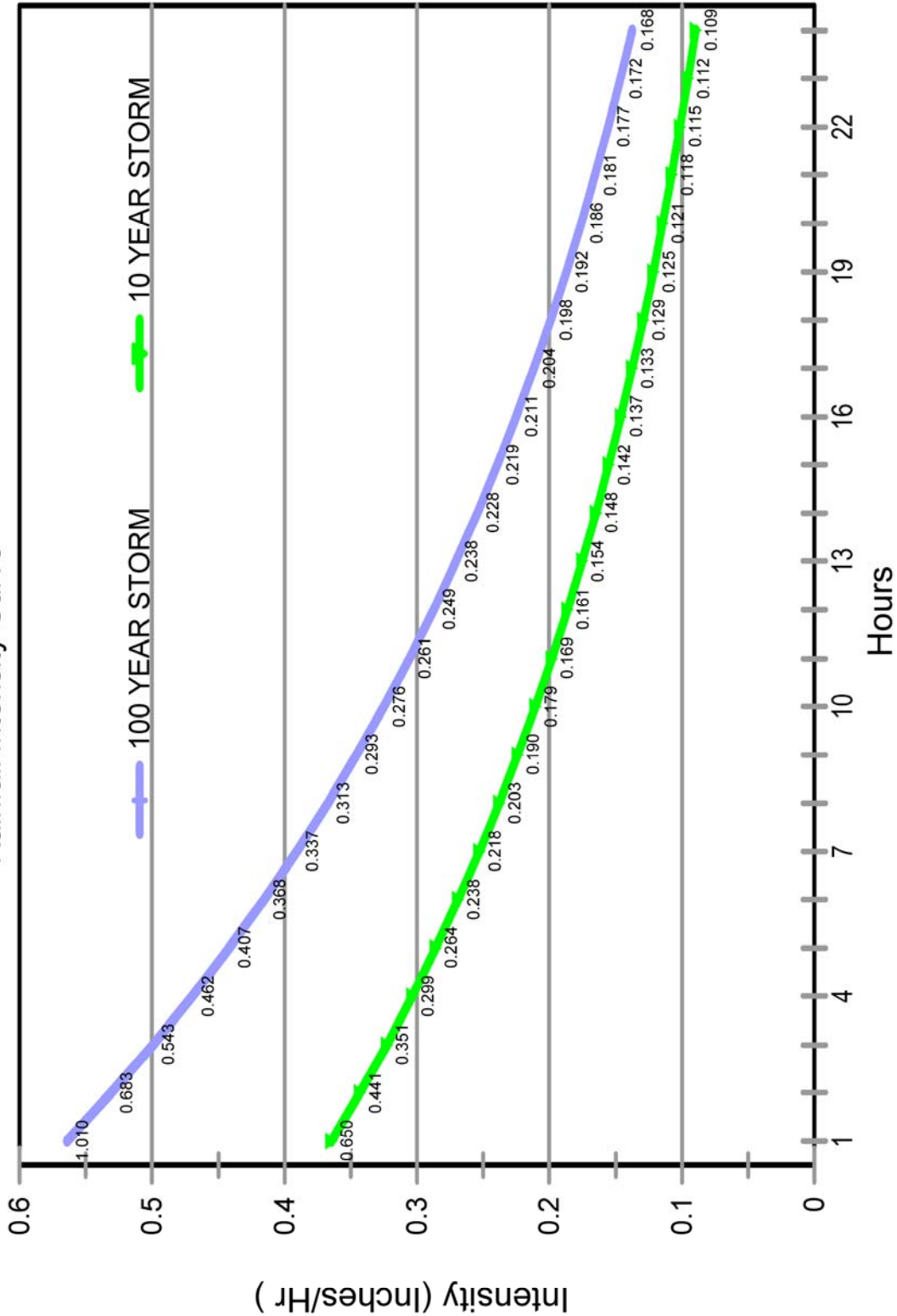

$$10 \text{ YR} = 6.464/T_c^{0.5609}$$

$$100 \text{ YR} = 10.1557/T_c^{0.5638}$$

RAINFALL INTENSITY IN INCHES PER HOUR  
T<sub>c</sub> = TIME OF CONCENTRATION

NO.	REVISED	BY
DRAWN BY: MCP		
CHECKED BY: DJR		
V:\125_City of Ripon Standards\Standard Specifications\Drawings\Storm\SD-3c.dwg		

### Rainfall Intensity Curves

# CITY OF RIPON

APPROVED

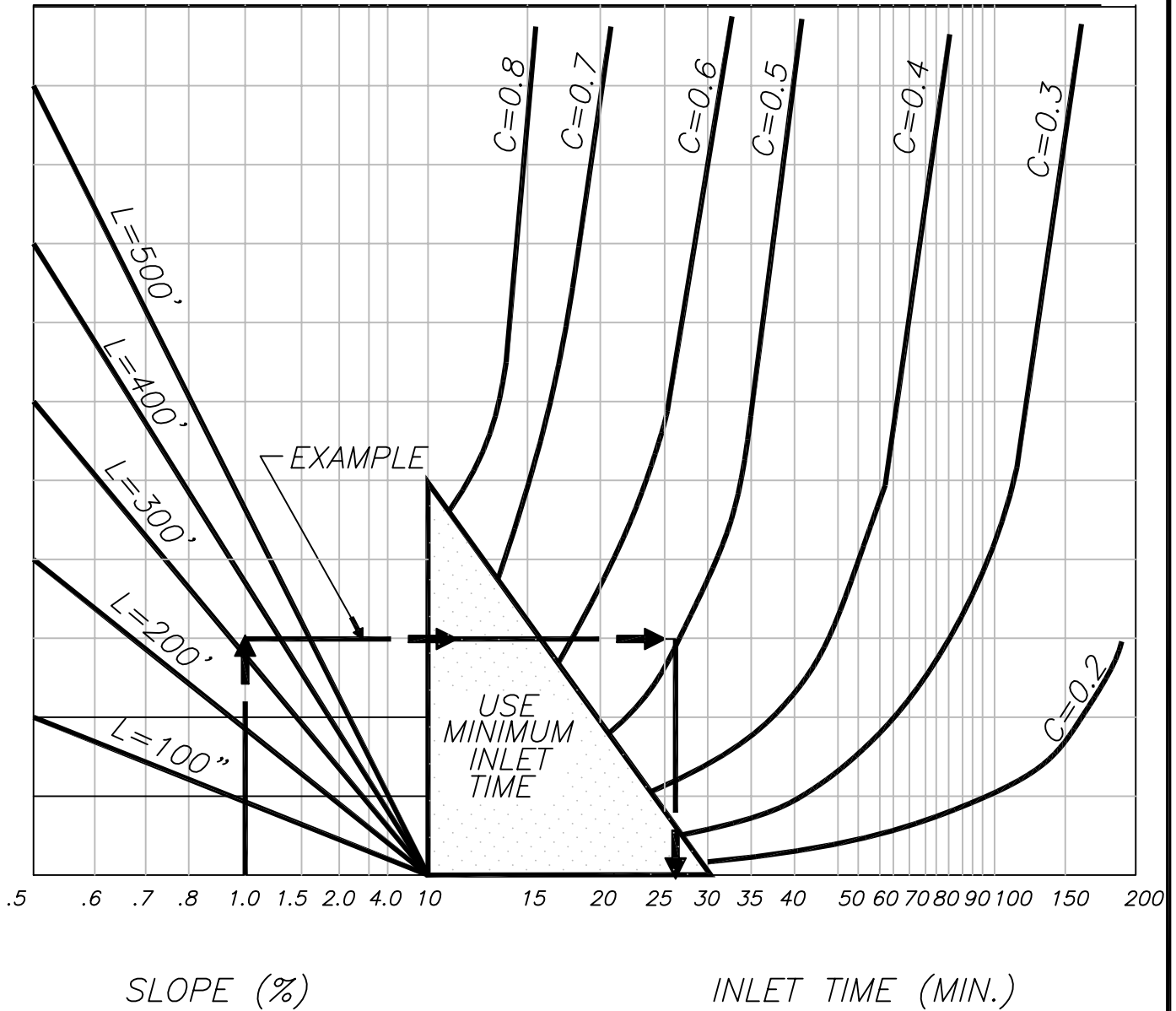
CITY ENGINEER RCE-28191
DATE: 2-2-99
STANDARD NO. SD-3c



EXAMPLE:

GIVEN: SLOPE = 1%  
 LENGTH = 300'  
 COEFFICIENT OF RUNOFF = 0.5  
 READ: INLET TIME = 26 MIN.

NOTE:

WHERE FIRST INLET IS IN A PUBLIC STREET, SUCH AS IN A SINGLE-FAMILY SUBDIVISION, USE ONLY SLOPE AND DISTANCE FROM BACK OF LOT TO THE STREET GUTTER. (DISREGARD STREET GUTTER FLOW TIME.)

NO.	REVISED	BY	<b>Inlet Time</b>	APPROVED	 CITY ENGINEER RCE-28191
				DATE: 2-2-99	
DRAWN BY: MATT				STANDARD NO. <b>SD-4</b>	
CHECKED BY: DJR			<b>CITY OF RIPON</b>		
V:\125_City of Ripon Standards\Standard Specifications\Drawings\Storm\SD-4.dwg					

# STORM DESIGN SHEET

JOB NO. \_\_\_\_\_ PAGE \_\_\_\_\_  
 DES. BY \_\_\_\_\_ DATE \_\_\_\_\_  
 CHKD. BY \_\_\_\_\_ DATE \_\_\_\_\_

## CITY OF RIPON

BEGINNING DESIGN DATA ASSUMED TIME TO INLET = \_\_\_\_\_ MINUTES  
 ELEVATION HGL AT BEGINNING OF SYSTEM = \_\_\_\_\_  $\Delta$  HGL ELEV. \_\_\_\_\_  
 ELEVATION HGL AT END OF SYSTEM = \_\_\_\_\_ APPROX. SYSTEM LENGTH \_\_\_\_\_  
 APPROX. SYSTEM LENGTH \_\_\_\_\_

SUBJECT \_\_\_\_\_  
 \_\_\_\_\_  
 DESCRIPTION \_\_\_\_\_  
 \_\_\_\_\_

POINT OF CONCENTRATION	CONTRIB. AC. (A)	RUN OFF COEF c	CA	$\Sigma$ CA	INTEND CITY (i)	Q cfs ( $\Sigma CA \times 1$ )	PIPE DIA	SLOPE FT/FT	LENGTH (FT)	$\Delta$ ELEV (FT)	ELEV HGL (FT)	VELOCITY (FT/S)	T MIN IN PIPE	T MIN TOTAL

NO.	REVISED	BY
DRAWN BY: TP		
CHECKED BY: DJR		

### Storm Drain Design Sheet

APPROVED  
*David J. Ripon*  
 CITY ENGINEER RCE-28191  
 DATE: 2-2-99

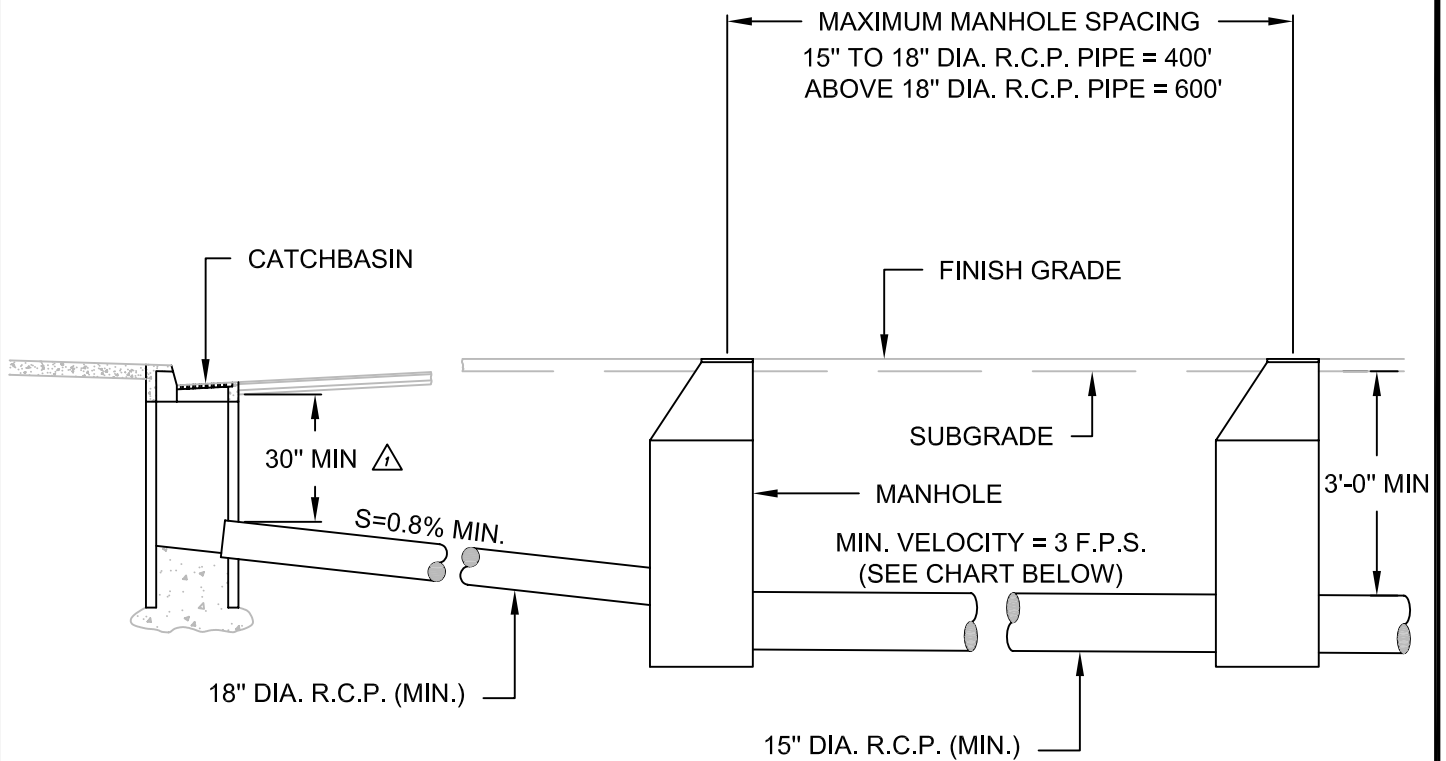

PIPE	"n"	MIN. SLOPE
15"	0.015	.0035
18"	0.013	.0026
24"	0.013	.0018
30"	0.013	.0013
36"	0.013	.001
42"	0.013	.0008
48"	0.013	.0007
54"	0.013	.0006
60"	0.013	.00055
72"	0.013	.0005

**NOTES:**

1. CATCHBASINS SHALL BE INSTALLED AT ALL INTERSECTIONS.
2. ALL CATCHBASIN LATERALS SHALL BE CONNECTED AT MANHOLES AND NOT DIRECTLY INTO TRUNK LINES.
3. LENGTH OF A SINGLE GUTTER FLOWING TO ANY CATCHBASIN SHALL NOT EXCEED 600 FT.
4. ALL STORM DRAINS TO BE DESIGNED FOR GRAVITY FLOW. (MATCHING OF PIPE CROWNS, NOT INVERT ELEVATIONS).
5. RUBBER GASKETED PIPE REQUIRED.
6. PIPE SHALL BE A MINIMUM OF CLASS III R.C.P. ONLY.

NO.	REVISED	BY	<b>Storm Drain Data</b>	APPROVED
△	1-2003	MJM		 CITY ENGINEER RCE-28191
DRAWN BY: TP				DATE: 2-2-99
CHECKED BY: DJR			<b>CITY OF RIPON</b>	STANDARD NO. <b>SD-6</b>
V:\25_City of Ripon Standards\Standard Specifications\Drawings\Storm\SD-6.dwg				



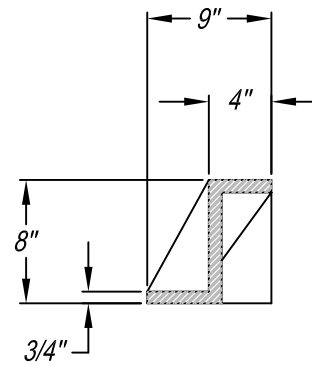
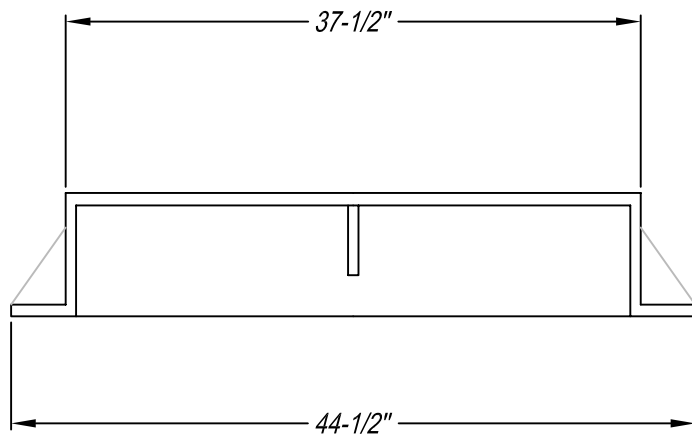

**HOOD DETAIL**

(SEE NOTE 5)

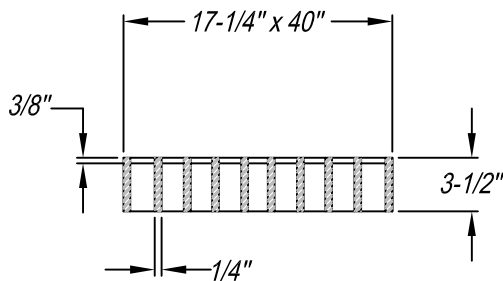

**GRATE DETAIL**

(SEE NOTE 7)

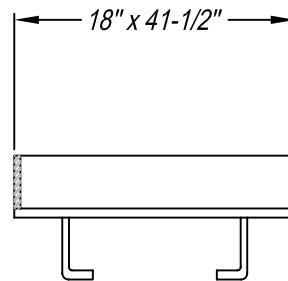

**FRAME DETAIL**

(SEE NOTE 6)

**NOTES:**

1. FRAME AND HOOD SHALL BE MANUFACTURED OF CAST IRON CONFORMING TO A.S.T.M. A-48 CLASS 35B.
2. FRAME, GRATE, AND HOOD SHALL BE H-20 RATED.
3. GRATE SHALL BE HOT-DIPPED GALVANIZED AND CHAINED TO FRAME.
4. FRAME AND HOOD SHALL BE COATED WITH BITUMINOUS MATERIAL CONFORMING TO A.W.W.A. C 203.
5. HOOD SHALL BE D&L FOUNDRY I-3541 OR APPROVED EQUAL.
6. FRAME SHALL BE D&L FOUNDRY I-3542 OR APPROVED EQUAL.
7. GRATE SHALL BE D&L FOUNDRY I-3543 HOT DIPPED GALVANIZED OR APPROVED EQUAL.



NO.	REVISED	BY	<b>Frame and Grate Type 2 Curb Inlet Catch Basin</b>	APPROVED
				<i>[Signature]</i> CITY ENGINEER RCE-28191
				DATE: 2-2-99
DRAWN BY: MCP			<b>CITY OF RIPON</b>	STANDARD NO. <b>SD-7</b>
CHECKED BY: DJR				
V: 125_City of Ripon Standards   Standard Specifications   Drawings   Storm   SD-7.dwg				

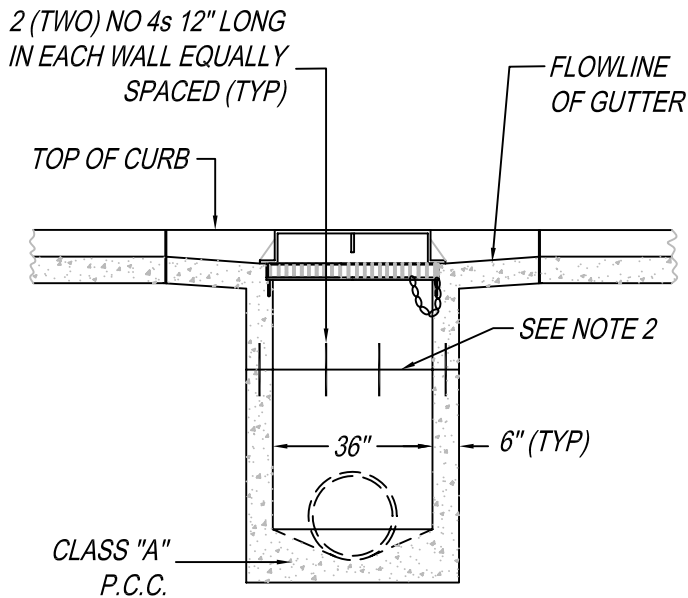
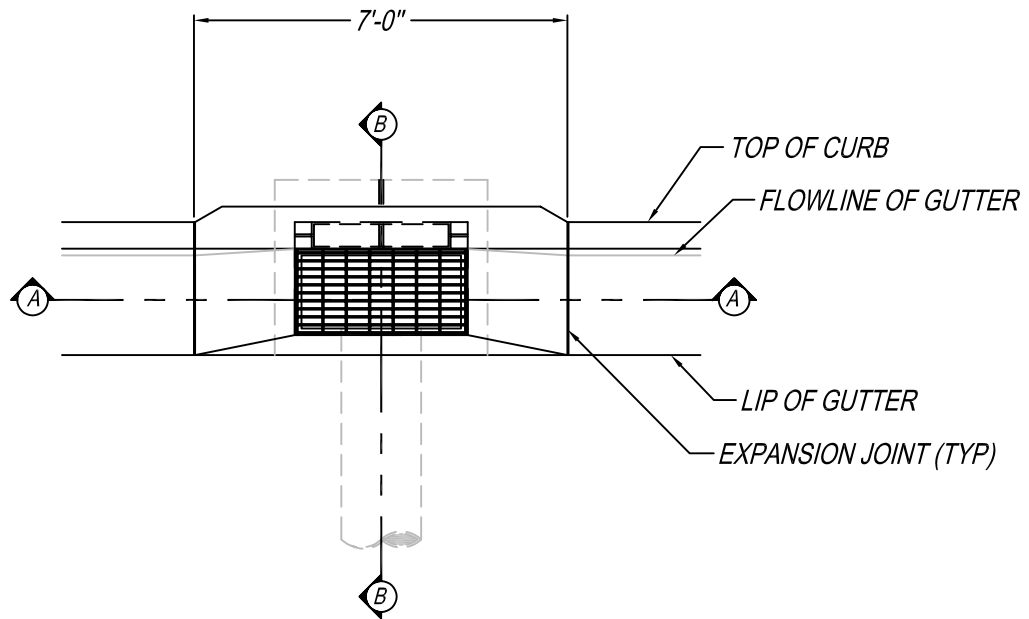

**SECTION A-A**

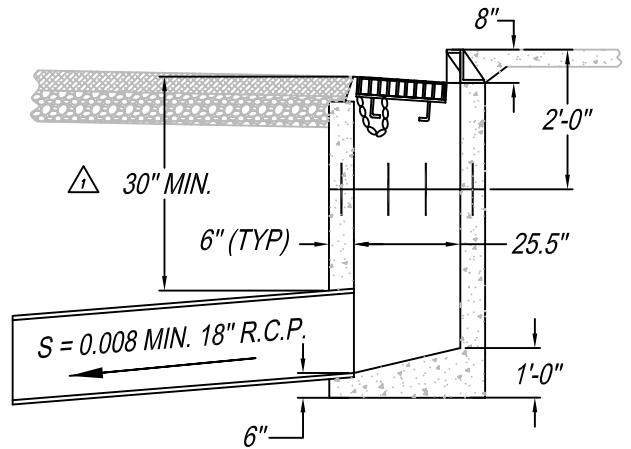

**SECTION B-B**

**NOTES:**

1. PRECAST CATCH BASIN MAY BE USED.
2. CATCH BASIN WALLS MAY BE POURED TO AN ELEVATION NOT LESS THAN 2'-0" BELOW TOP OF CURB. IT SHALL BE THE RESPONSIBILITY OF THE CONTRACTOR TO FRAME IN AND POUR THE UPPER 2'-0" OF THE CATCH BASIN MONOLITHICALLY WITH THE CURB AND GUTTER.
3. GRATE AND FRAME SHALL CONFORM TO CITY OF RIPON STANDARD SD-7.
4. TYPE 2 CATCH BASIN TO BE INSTALLED IN INDUSTRIAL AND COMMERCIAL AREAS AS REQUIRED BY THE CITY OF RIPON.
5. CATCH BASIN RIM TO BE SET 1-1/2" BELOW FLOWLINE OF GUTTER.

NO.	REVISED	BY
△	1-2003	MJM
DRAWN BY: MCP		
CHECKED BY: DJR		
V:125 City of Ripon Standards   Standard Specifications   Drawings   Storm   SD-7a.dwg		

**Type 2 Curb Inlet  
Catch Basin**

**CITY OF RIPON**

APPROVED

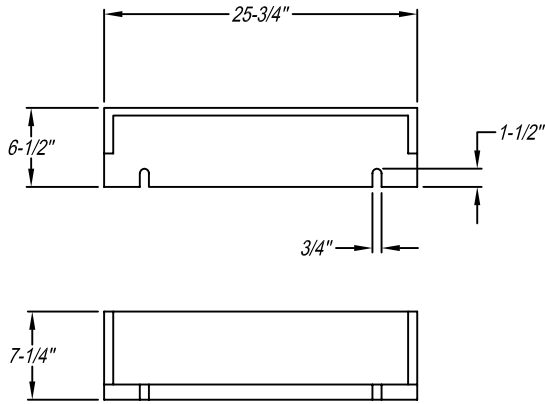
CITY ENGINEER RCE-28191
DATE: 2-2-99
STANDARD NO. <b>SD-7a</b>

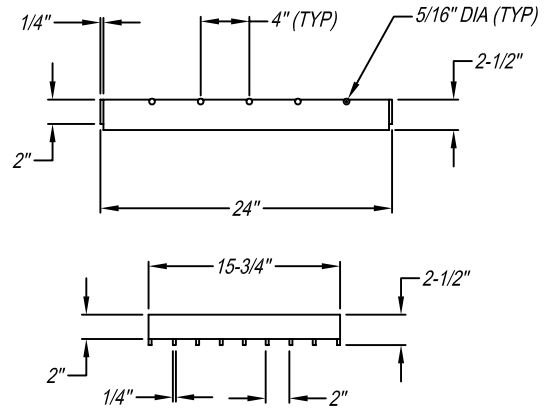

**HOOD DETAIL**

(SEE NOTE 5)



**GRATE DETAIL**

(SEE NOTE 7)

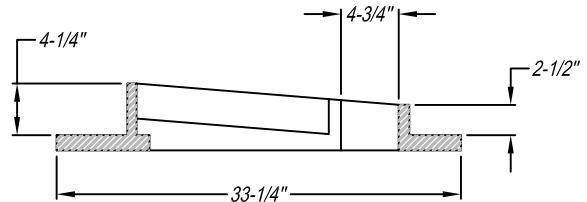
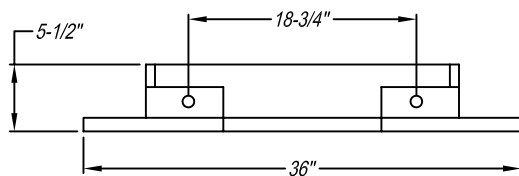
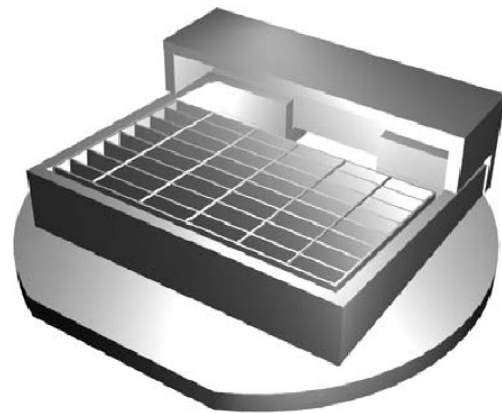
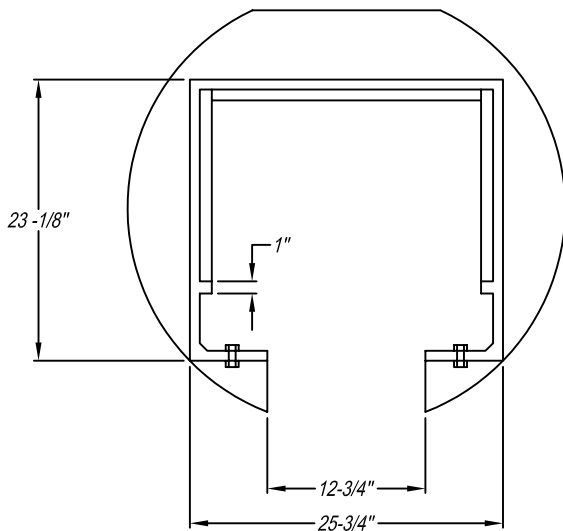

**FRAME DETAIL**

(SEE NOTE 6)

**NOTES:**

1. FRAME AND HOOD SHALL BE MANUFACTURED OF CAST IRON CONFORMING TO A.S.T.M. A-48 CLASS 35B.
2. FRAME, GRATE, AND HOOD SHALL BE H-20 RATED.
3. GRATE SHALL BE HOT-DIPPED GALVANIZED AND CHAINED TO FRAME.
4. FRAME AND HOOD SHALL BE COATED WITH BITUMINOUS MATERIAL CONFORMING TO A.W.W.A. C 203.
5. HOOD SHALL BE D&L FOUNDRY I-3560 OR APPROVED EQUAL.
6. FRAME SHALL BE D&L FOUNDRY I-3560 OR APPROVED EQUAL.
7. GRATE SHALL BE D&L FOUNDRY I-3560 HOT DIPPED GALVANIZED OR APPROVED EQUAL.

NO.	REVISED	BY
DRAWN BY: MCP		
CHECKED BY: DJR		
V: 125_City of Ripon Standards   Standard Specifications   Drawings   Storm   SD-8.dwg		

**Frame and Grate  
Type 1 Curb Inlet  
Catch Basin**

**CITY OF RIPON**

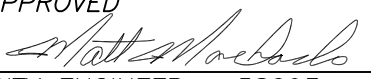
APPROVED

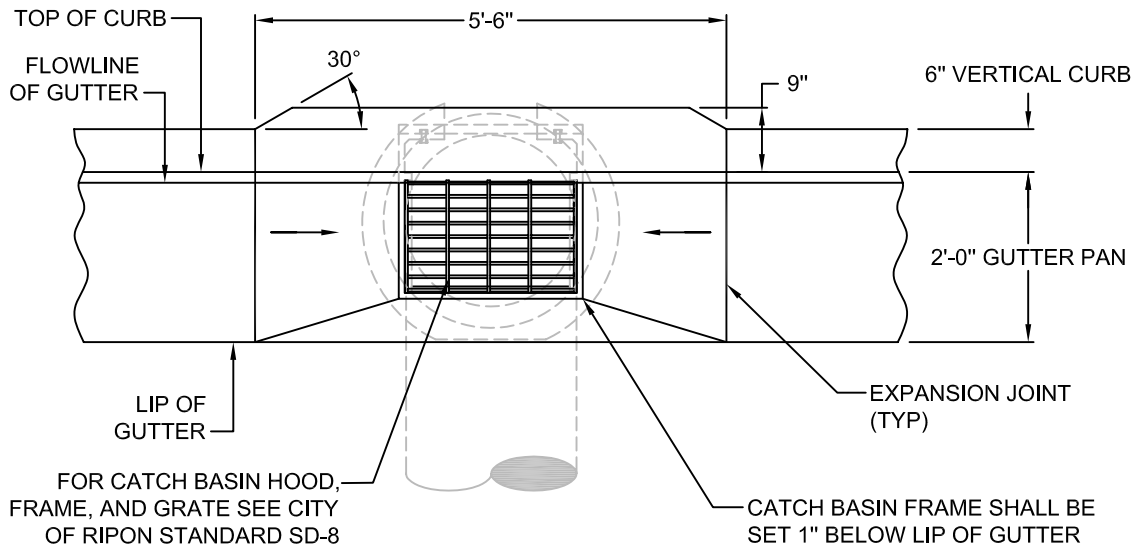
CITY ENGINEER 58093
DATE: 11-7-00
STANDARD NO. SD-8

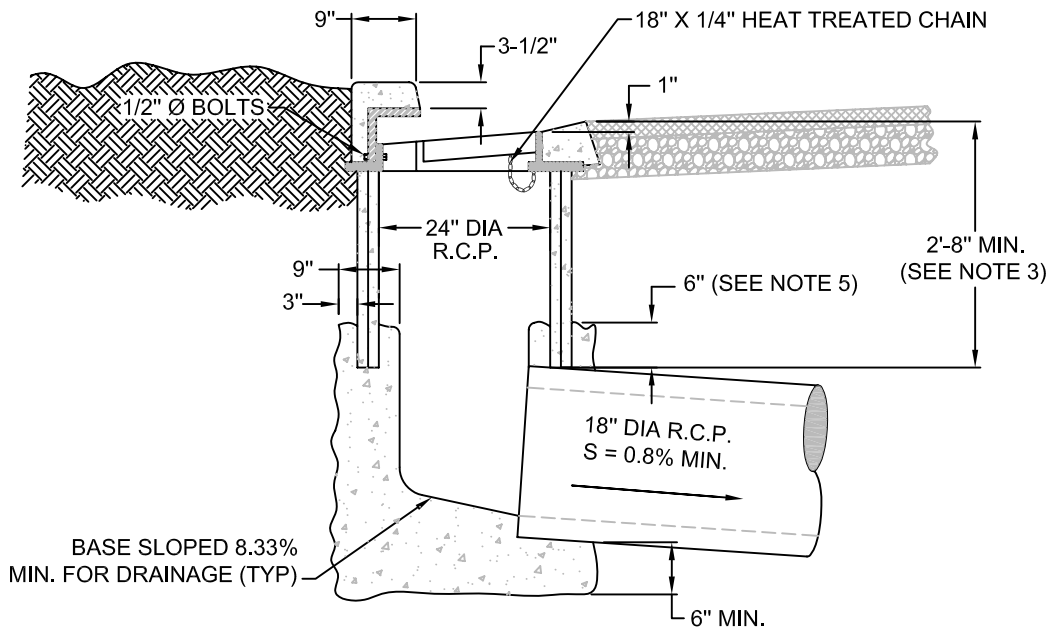

**PLAN VIEW**



**SECTION VIEW**

**NOTES:**

1. ALL EXPOSED STEEL SHALL BE GALVANIZED AFTER FABRICATION.
2. CHAIN GRATE TO FRAME
3. 2'-8" MIN. BELOW PAVING IN NEW STREET DEVELOPMENT, IN EXISTING STREETS 2'-0" MAY BE USED WITH APPROVAL OF CITY ENGINEER.
4. 24" PIPE BARREL SHALL BE CLASS II, R.C.P. NO BELL OR SPIGOTS ARE ALLOWED TO BE USED IN THE RISER PIPE BARREL, UNLESS THE CATCH BASIN IS DEEP ENOUGH TO CALL FOR TWO STICKS OF CONCRETE PIPE.
5. 24" R.C.P. RISER PIPE MUST BE WET SET INTO CATCH BASIN BASE WHILE CONCRETE IS STILL WET TO INSURE PROPER BONDING AND SEALING BETWEEN BASE AND CATCH BASIN RISER.

NO.	REVISED	BY	<p><b>24" Round Curb Inlet Catch Basin Detail</b></p>	APPROVED	<p><i>[Signature]</i> CITY ENGINEER RCE-28191</p>
				DATE: 2-2-99	
				STANDARD NO. <b>SD-8a</b>	
DRAWN BY: TP			<p><b>CITY OF RIPON</b></p>		
CHECKED BY: DJR					
V:\25_City of Ripon Standards\Standard Specifications\Drawings\Storm\SD-8a.dwg					

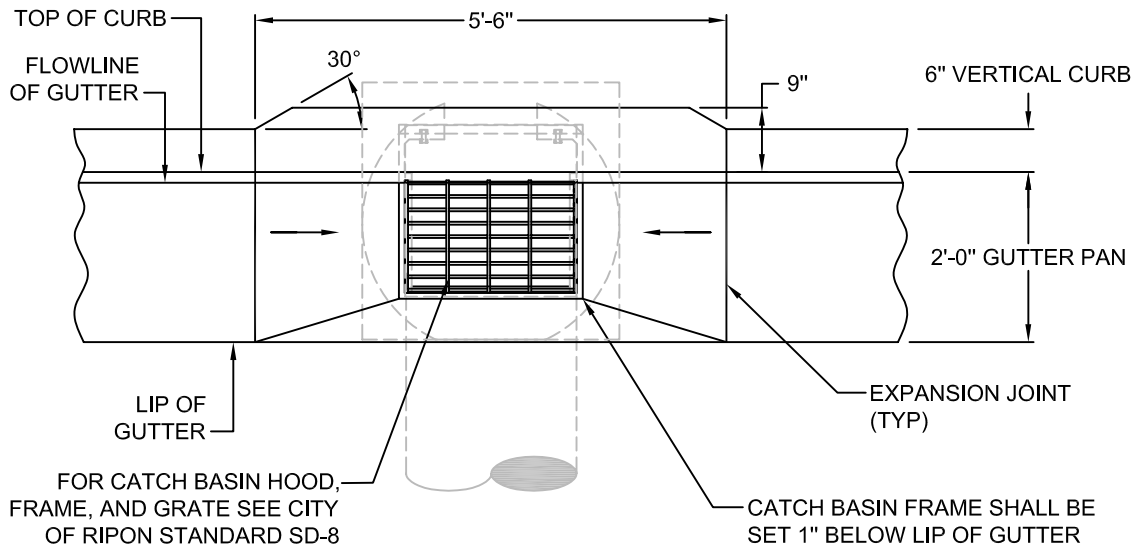

**PLAN VIEW**

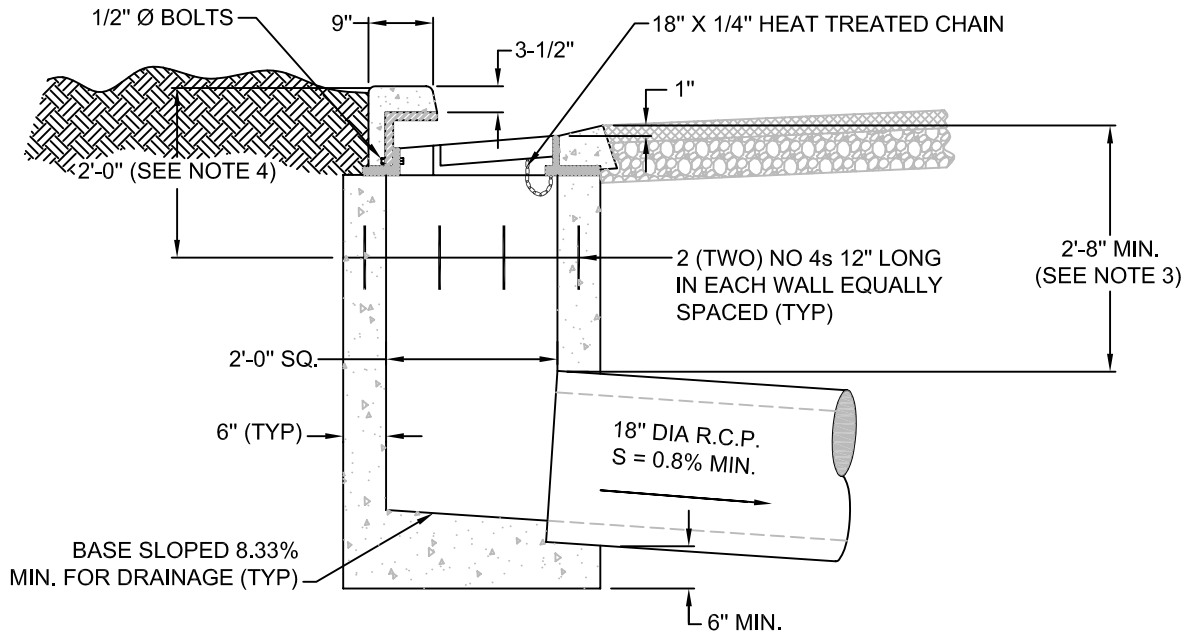

**SECTION VIEW**

**NOTES:**

1. ALL EXPOSED STEEL SHALL BE GALVANIZED AFTER FABRICATION.
2. CHAIN GRATE TO FRAME
3. 2'-8" MIN. BELOW PAVING IN NEW STREET DEVELOPMENT, IN EXISTING STREETS 2'-0" MAY BE USED WITH APPROVAL OF CITY ENGINEER.
4. CATCH BASIN WALLS MAY BE POURED TO AN ELEVATION NOT LESS THAN 2'-0" BELOW TOP OF CURB. IT SHALL BE THE RESPONSIBILITY OF THE CONTRACTOR TO FRAME IN AND POUR THE UPPER 2'-0" OF THE CATCH BASIN MONOLITHICALLY WITH THE CURB AND GUTTER.

NO.	REVISED	BY	<p><b>24" Square Curb Inlet Catch Basin Detail</b></p>	APPROVED	 CITY ENGINEER 58093
				DATE: 11-7-00	
DRAWN BY: TP					
CHECKED BY: DJR			CITY OF RIPON	STANDARD NO. <b>SD-8b</b>	
V:\25_City of Ripon Standards\Standard Specifications\Drawings\Storm\SD-8b.dwg					

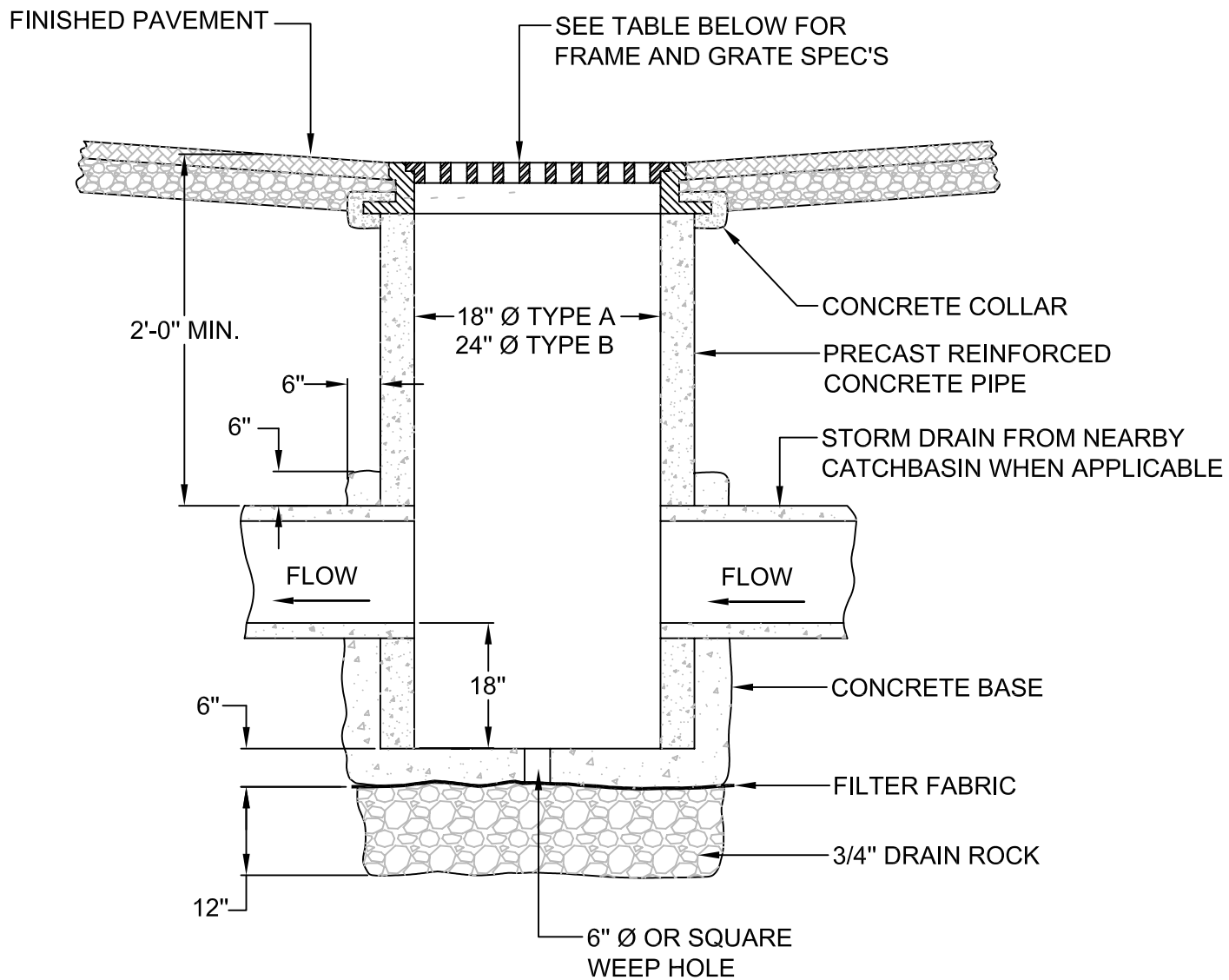

SOUTH BAY FOUNDRY SCHEDULE	
TYPE A	SBF - 1803 FRAME & GRATE
TYPE B	SBF - 101 FRAME SBF - 108 GRATE

(OR APPROVED EQUALS)

**NOTES:**

1. SUMP REQUIRED ONLY ON LAST CATCH BASIN PRIOR TO CONNECTION TO THE CITY'S STORM FACILITIES.

NO.	REVISED	BY	<b>Parking Lot Catch Basin</b>	APPROVED
				<i>Daniel R...</i> CITY ENGINEER RCE-28191
DRAWN BY: TP				DATE: 2-2-99
CHECKED BY: DJR			<b>CITY OF RIPON</b>	STANDARD NO. <b>SD-9</b>
V:\125_City of Ripon Standards\Standard Specifications\Drawings\Storm\SD-9.dwg				

MANHOLE FRAME AND COVER  
FOR DETAILS REFER TO CITY  
OF RIPON STANDARD NO. SD-15

FINISHED GRADE

SECURE FRAME TO MANHOLE  
RINGS WITH CONCRETE, PER  
CITY OF RIPON STANDARD M-6.

INSTALL GRADE RINGS AS  
REQUIRED FOR GRADE, 12"  
MAXIMUM (GROUT IN PLACE)  
(SEE NOTES 2 & 3)

ALL HANDLING HOLES, TO  
BE PLUGGED WITH MORTAR  
AFTER INSTALLATION

STANDARD ECCENTRIC CONE MANHOLE,  
FRAME AND COVER TO BE CENTERED ON  
MAINLINE (SEE NOTE 4)

STANDARD 12" CONCENTRIC CONE  
SECTION REDUCING FROM 60"  
TO 48" I.D. MANHOLE

ALL JOINTS SHALL EITHER BE SET ON A  
FULL MORTARED BED OR SET USING  
RAMSNECK. ALL JOINTS SHALL BE BANDED  
WITH MORTAR ON THE INTERIOR SURFACE.

PRECAST REINFORCED CONCRETE  
MANHOLE UNITS (SEE NOTE 1)

CLASS "B" CONCRETE  
FOR MANHOLE BASE  
(SEE NOTE 6)

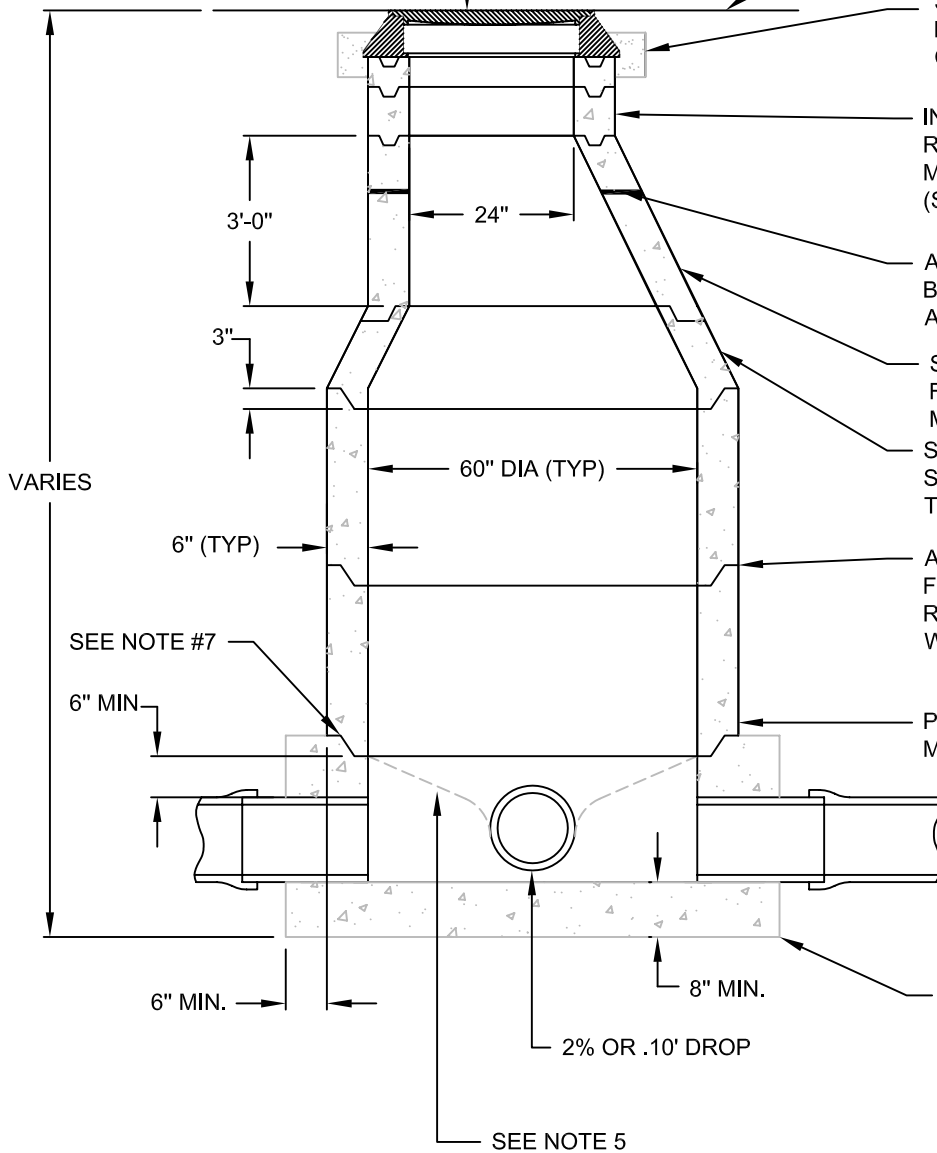

**NOTES:**

1. PRECAST REINFORCED CONCRETE MANHOLE UNITS SHALL CONFORM TO A.S.T.M. C-478.
2. NUMBER OF GRADE RINGS TO BE KEPT AT A MINIMUM FOR ORIGINAL CONSTRUCTION TO ALLOW FOR FUTURE PAVEMENT ADJUSTMENTS.
3. PRIOR APPROVAL MUST BE OBTAINED FROM EITHER THE CITY ENGINEER OR CITY FIELD INSPECTOR BEFORE INSTALLING MORE THAN 12" OF GRADE RINGS.
4. CONCENTRIC CONES MAY BE USED ONLY WITH PRIOR APPROVAL FROM EITHER THE CITY ENGINEER OR CITY FIELD INSPECTOR.
5. STORM PIPE MAY BE LAID THROUGH THE MANHOLE AND THE TOP PORTION REMOVED, VIA SAW CUTTING, AFTER THE CONCRETE BASE HAS SET.
6. MANHOLE BASE SHALL HAVE A LIGHT BROOM FINISH.
7. BOTTOM MANHOLE SECTION SHALL BE WET-SET OR SET IN FORMED GROOVE.

NO.	REVISED	BY	<b>Type 1 Standard Storm Manhole</b>	APPROVED
				 CITY ENGINEER RCE-28191
				DATE: 2-2-99
DRAWN BY: TP			<b>CITY OF RIPON</b>	STANDARD NO. SD-10
CHECKED BY: DJR				
V:\25_City of Ripon Standards\Standard Specifications\Drawings\Storm\SD-10.dwg				

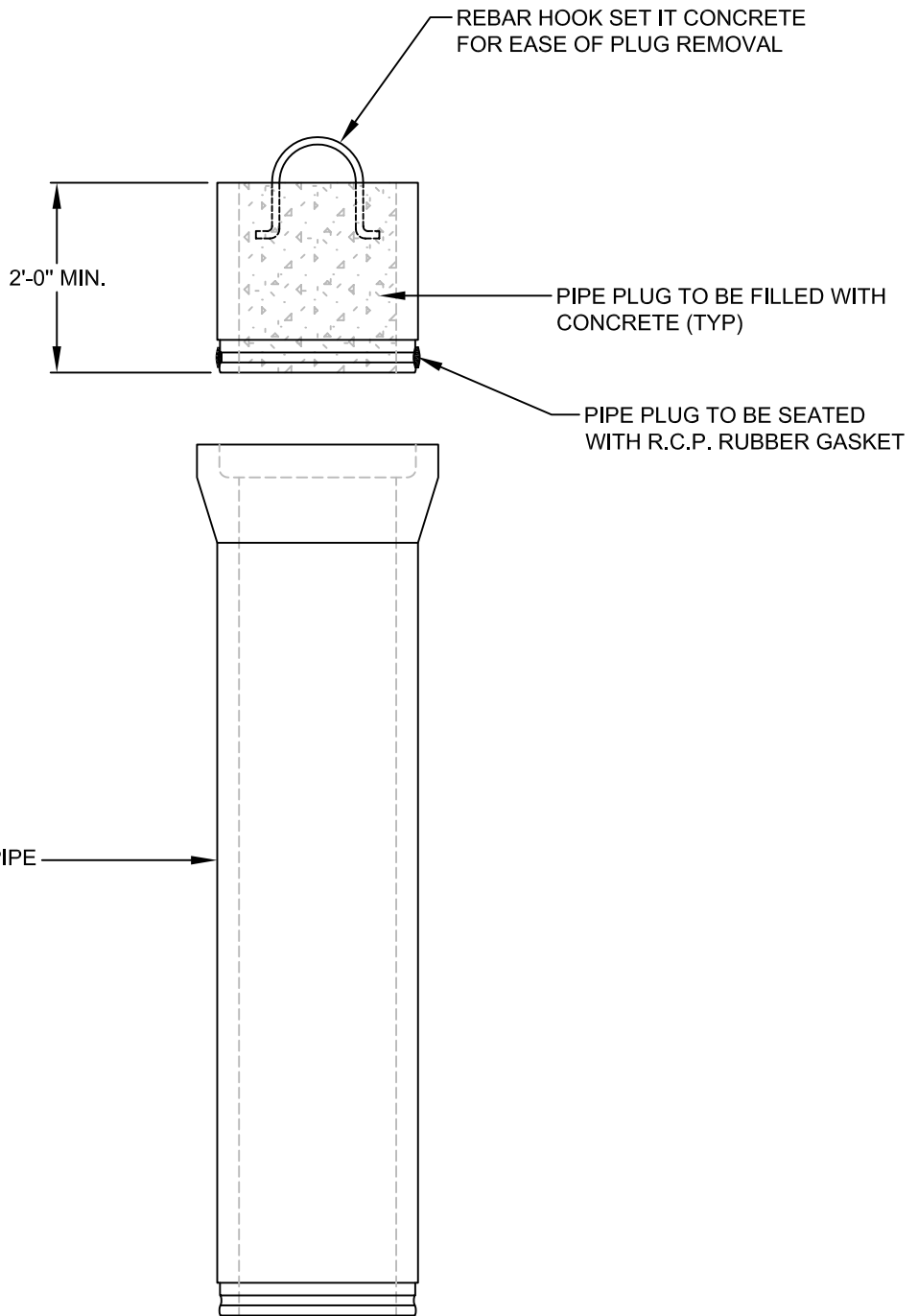

NO.	REVISED	BY	<b>Storm Drain Plug</b>	APPROVED
				<i>[Signature]</i>
				CITY ENGINEER RCE-28191
DRAWN BY: MCP				DATE: 2-2-99
CHECKED BY: DJR			<b>CITY OF RIPON</b>	STANDARD NO. <b>SD-10a</b>
V:\25_City of Ripon Standards\Standard Specifications\Drawings\Storm\SD-10a.dwg				



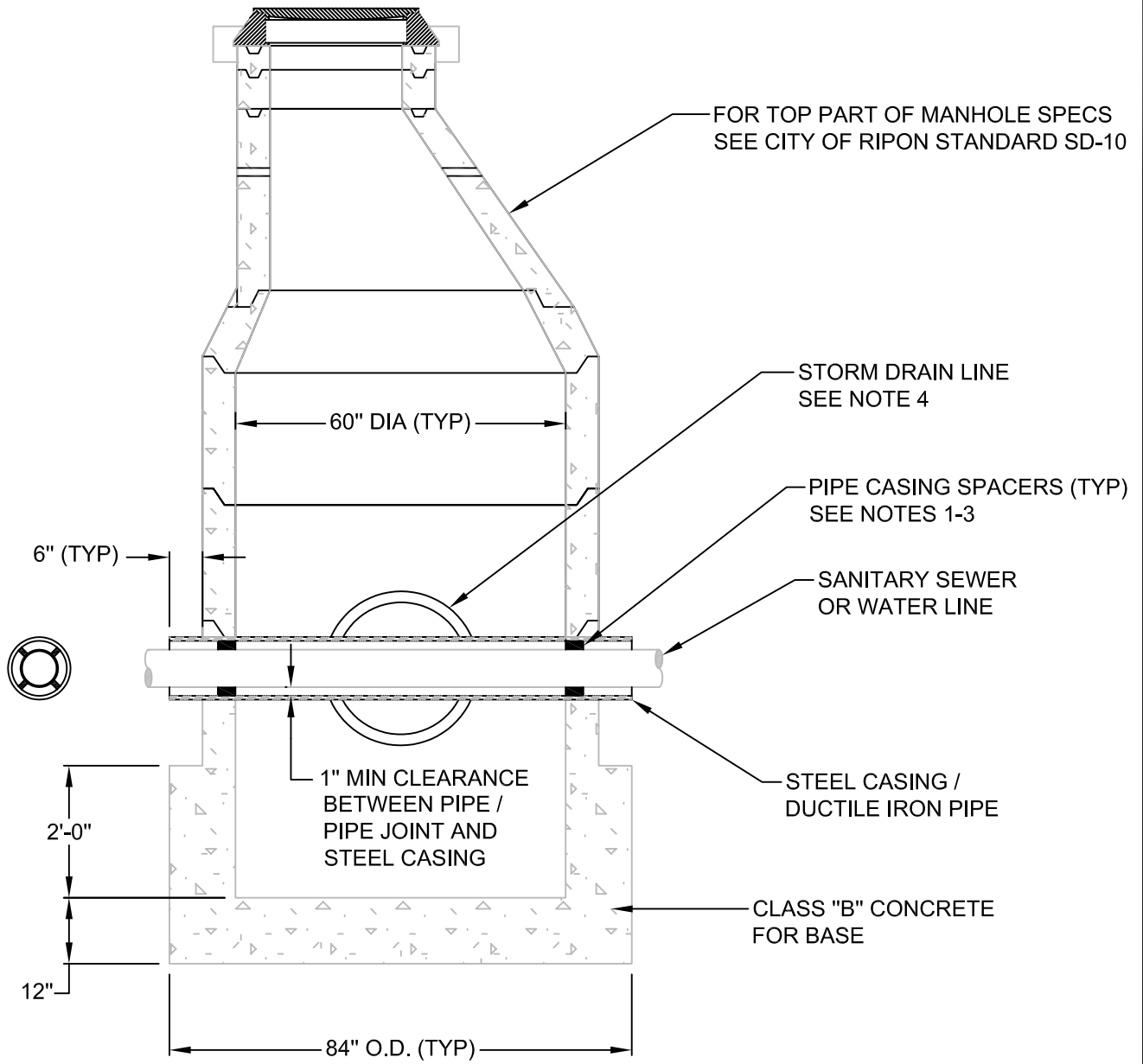

**NOTES:**

1. SPACERS SHALL BE BOLT ON STYLE, TWO PIECE SHELL OF 304 STAINLESS STEEL OF A MINIMUM 14 GAUGE THICKNESS. SHELL SHALL BE LINED WITH RIBBED PVC SHEET OF A 0.090" THICKNESS, WITH OVERLAPS AT EDGES. (CASCADE TYPE CCS SPACERS OR APPROVED EQUAL)
2. FOR PIPE DIAMETERS 4" THROUGH 12" INSTALL STAINLESS STEEL PIPE CASING SPACERS 5'-0" OR LESS FROM EACH END OF PIPE, BUT NOT MORE THAN 10' APART (2 PER PIPE). FOR PIPE DIAMETERS 14" AND LARGER, INSTALL STAINLESS STEEL PIPE CASING SPACERS 5'-0" OR LESS FROM EACH END OF PIPE AND ONE CENTERED ON THE PIPE (3 PER PIPE).
3. ALTERNATE METHODS OF PIPE SUPPORT WITHIN THE CASING MUST BE APPROVED BY CITY ENGINEER PRIOR TO INSTALLATION.
4. MUST PROVIDE HEAD LOSS CALCULATIONS TO THE CITY ENGINEER PRIOR TO CONSTRUCTION.

NO.	REVISED	BY	<p><b>Separation Manhole Detail</b></p>	APPROVED	 CITY ENGINEER RCE-28191
				DATE: 2-2-99	
DRAWN BY: TP				STANDARD NO. SD-11	
CHECKED BY: DJR			CITY OF RIPON		
V:\25_City of Ripon Standards\Standard Specifications\Drawings\Storm\SD-11.dwg					

FOR TOP PART OF MANHOLE SPECS  
SEE CITY OF RIPON STANDARDS SD-10

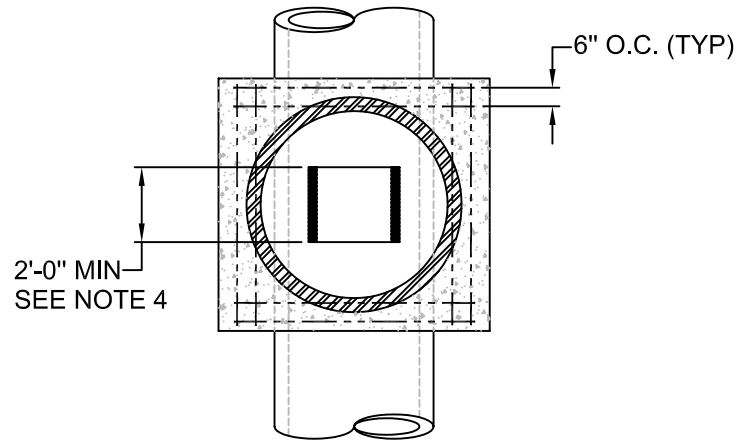
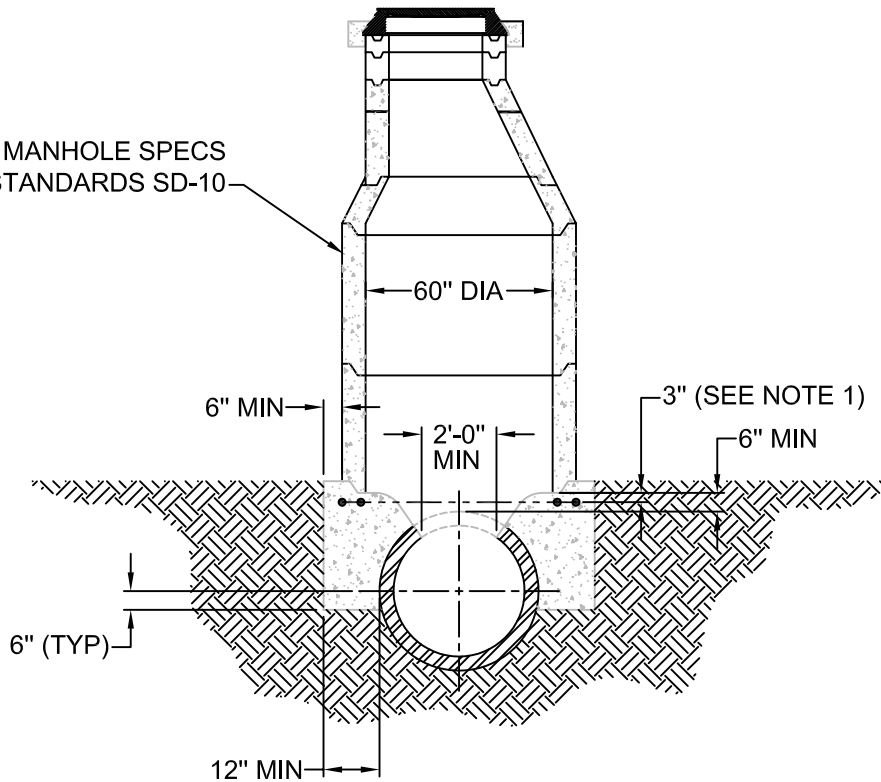

**EXAMPLE OF 42" R.C.P. DETAIL**

**NOTES:**

1. 2 (TWO) #5 REBAR EACH WAY ON 6" CENTERS.
2. BASE SHALL BE CLASS "B" CONCRETE.
3. SADDLE MANHOLES SHALL ONLY BE ALLOWED ON STORM DRAIN PIPE GREATER THAN 36 INCHES IN DIAMETER, PROVIDED THAT NO JUNCTION EXISTS WITH ANY OTHER STORM DRAIN PIPE AT THE MANHOLE.
4. 2'-0" SQUARE OR ROUND HOLE MINIMUM SAW CUT THROUGH REINFORCED CONCRETE PIPE ONLY.

NO.	REVISED	BY	<p><b>Type 2 Manhole for Pipe 36" Diameter and Larger</b></p>	APPROVED	 CITY ENGINEER RCE-28191
				DATE: 2-2-99	
DRAWN BY: MCP			<p><b>CITY OF RIPON</b></p>	STANDARD NO.	SD-12
CHECKED BY: DJR					
V:\125_City of Ripon Standards\Standard Specifications\Drawings\Storm\SD-12.dwg					

FOR TOP PART OF MANHOLE SPECS  
SEE CITY OF RIPON STANDARDS SD-10

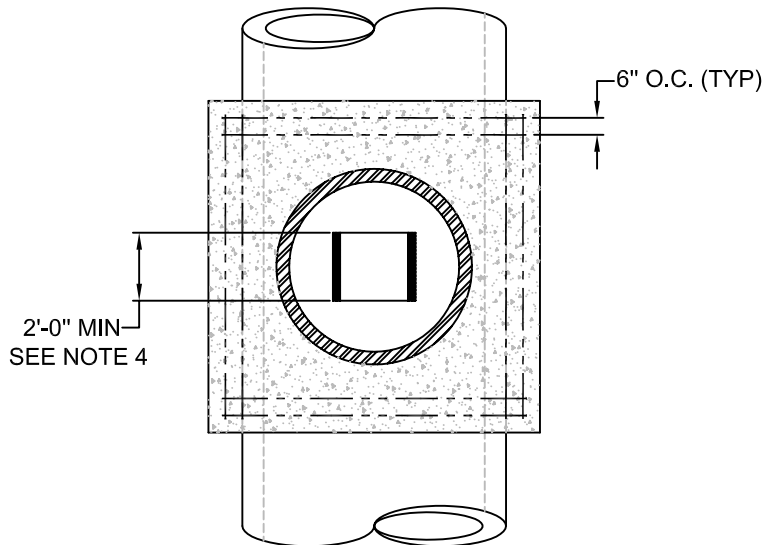
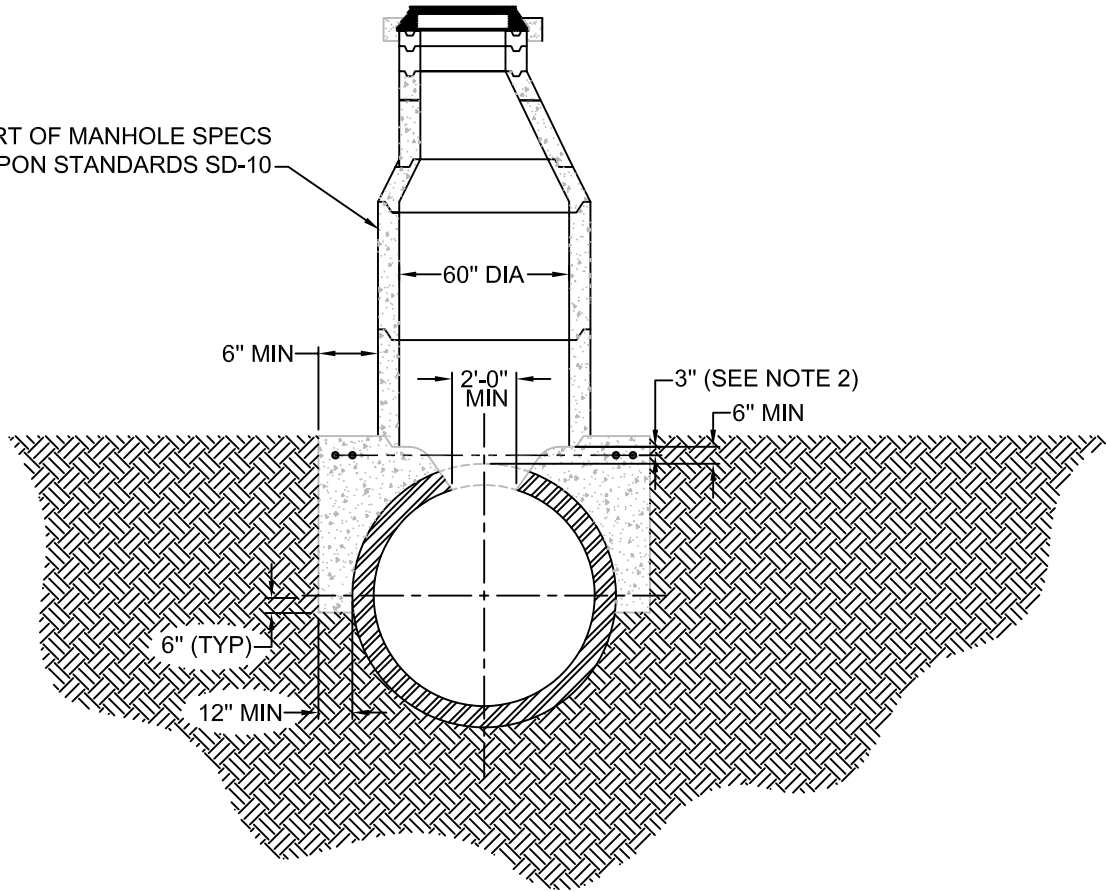

**EXAMPLE OF 78" R.C.P. DETAIL**

**NOTES:**

1. 2 (TWO) #5 REBAR EACH WAY ON 6" CENTERS.
2. BASE SHALL BE CLASS "B" CONCRETE.
3. SADDLE MANHOLES SHALL ONLY BE ALLOWED ON STORM DRAIN PIPE GREATER THAN 36 INCHES IN DIAMETER, PROVIDED THAT NO JUNCTION EXISTS WITH ANY OTHER STORM DRAIN PIPE AT THE MANHOLE.
4. 2'-0" SQUARE OR ROUND HOLE MINIMUM SAW CUT THROUGH REINFORCED CONCRETE PIPE ONLY.

NO.	REVISED	BY	<b>Type 2 Manhole for Pipe 36" Diameter and Larger</b>	APPROVED	
				 CITY ENGINEER RCE-28191	
				DATE: 2-2-99	
DRAWN BY: MCP			<b>CITY OF RIPON</b>	STANDARD NO.	SD-13
CHECKED BY: DJR					
V:\125_City of Ripon Standards\Standard Specifications\Drawings\Storm\SD-13.dwg					

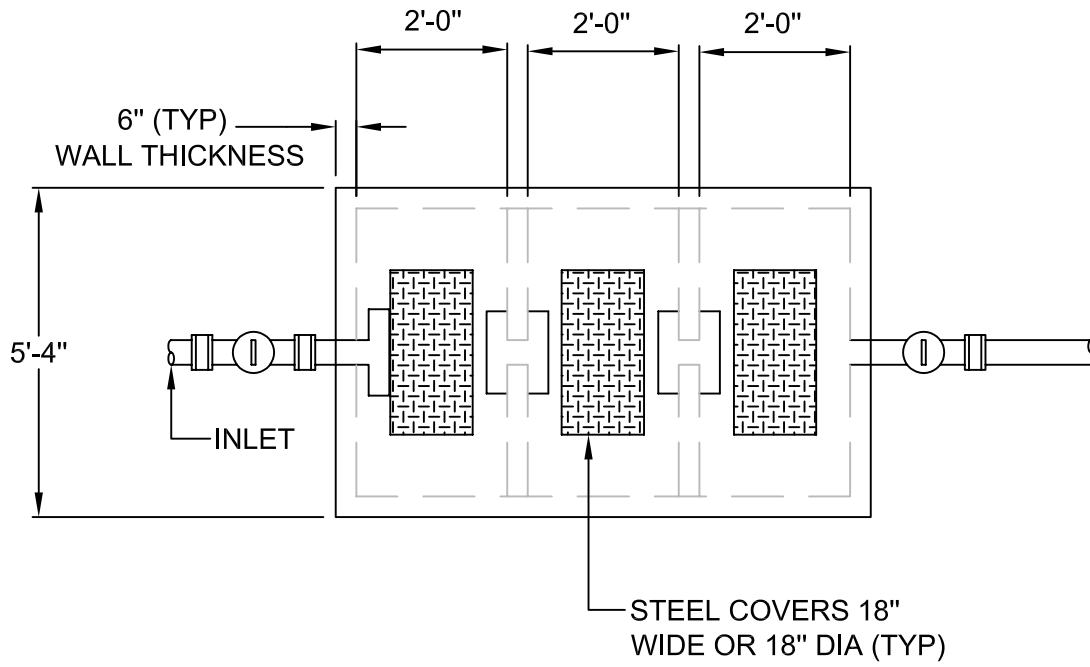

**PLAN VIEW**

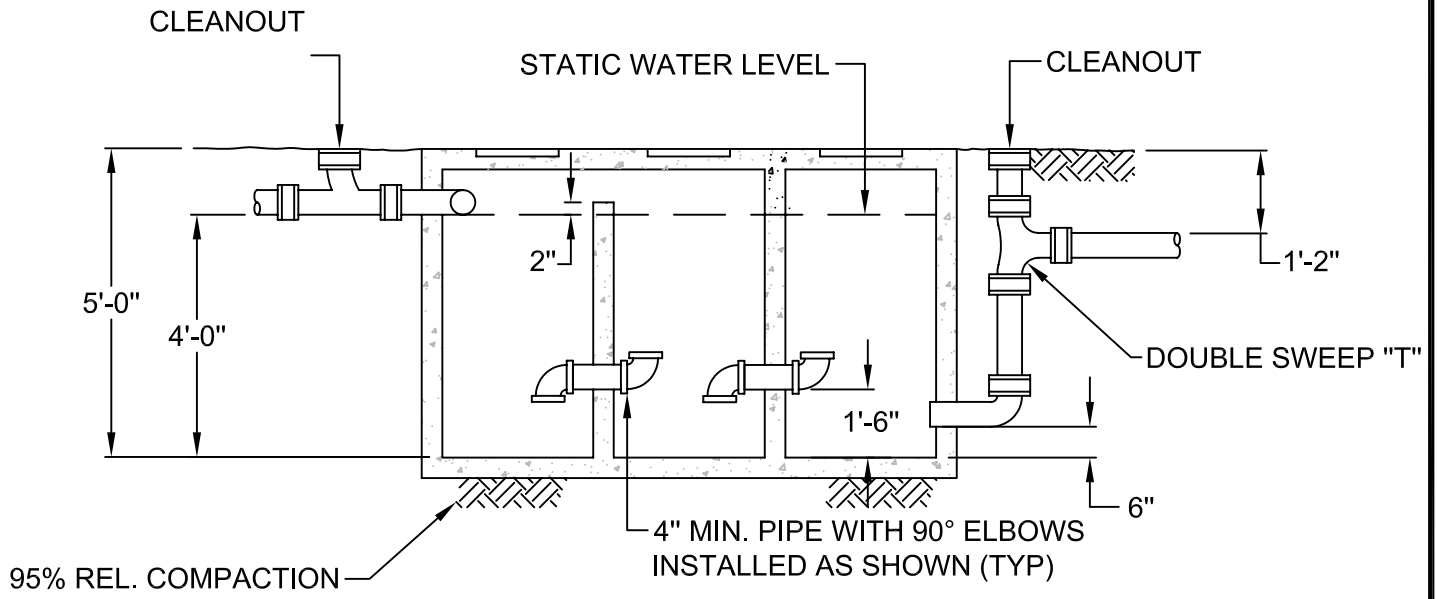

**SECTION VIEW**

**NOTES:**

1. DIMENSIONS SHOWN ARE FOR MINIMUM SIZE (750 GALLON) TRAP.
2. EACH UNIT SHALL BE DESIGNED BY A REGISTERED CIVIL ENGINEER AND APPROVED BY THE CITY ENGINEER. STREET INSTALLATIONS SHALL BE DESIGNED FOR H-20 LOADING.
3. CONCRETE SHALL BE A MINIMUM OF 3,000 PSI @ 28 DAYS.
4. ALL WASTE SHALL ENTER TRAP THROUGH INLET PIPE ONLY.
5. COVERS SHALL BE STEEL AND SHALL BE GAS TIGHT.
6. VELOCITY THROUGH TRAP WILL BE LESS THAN 2 FEET PER SECOND AT MAX. FLOW RATE.

NO.	REVISED	BY	<p><b>Typical Sand and Oil Trap</b></p>	APPROVED	 CITY ENGINEER RCE-28191
				DATE: 2-2-99	
				STANDARD NO. <b>SD-14</b>	
DRAWN BY: TP			<p><b>CITY OF RIPON</b></p>		
CHECKED BY: DJR					
V:\25_City of Ripon Standards\Standard Specifications\Drawings\Storm\SD-14.dwg					

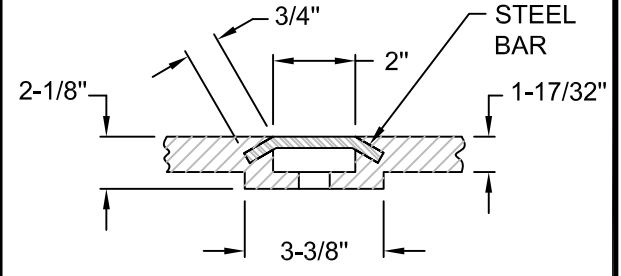
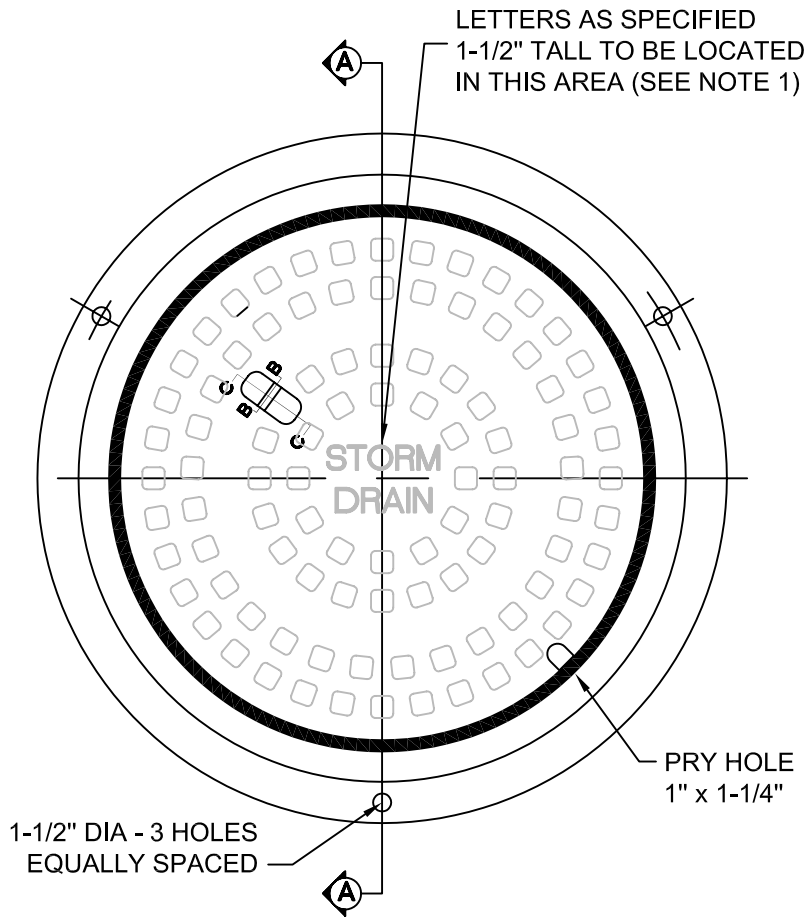

**SECTION B-B**

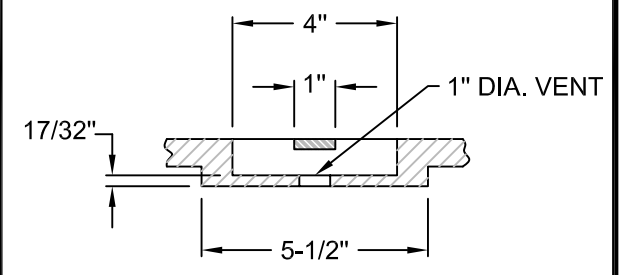

**SECTION C-C**

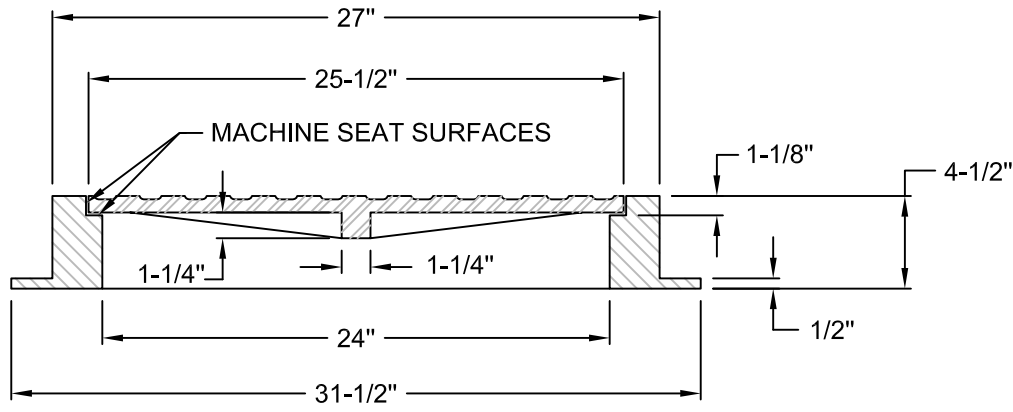

**SECTION A-A**

**NOTES:**

1. STORM DRAIN MANHOLES SHALL HAVE THE WORDS "STORM DRAIN" CASTED IN THE MANHOLE COVER AT THE LOCATION SHOWN ABOVE.
2. FRAME AND COVER SHALL BE MANUFACTURED OF CAST IRON CONFORMING TO A.S.T.M. A-48 CLASS 30.
3. FRAME AND COVER SHALL BE H-20 RATED.
4. FRAME SHALL WEIGH 140 LBS. MINIMUM AND COVER SHALL WEIGH 130 LBS. MINIMUM.

NO.	REVISED	BY	<p><b>Storm Drain Manhole Frame and Cover</b></p>	APPROVED	<p>CITY ENGINEER RCE-28191</p>
				DATE: 2-2-99	
DRAWN BY: MCP				STANDARD NO. <b>SD-15</b>	
CHECKED BY: DJR			<b>CITY OF RIPON</b>		
V:\25_City of Ripon Standards\Standard Specifications\Drawings\Storm\SD-15.dwg					

1. General: The interior of all sanitary sewer manholes downstream from pump stations, drop manholes, manhole pumping stations, and any other structure where the City Engineer determines that hydrogen sulfide gas may be a problem shall receive a polyurethane coating.
2. Material: The coating shall be high build, two-component, 100% solid, non-solvent, hybrid polyurethane material. The flash point of the individual components and the fluid mixture shall be a minimum of 415° F. Application shall be 125 mils in thickness.
3. The cured coating shall have a shore D hardness of 57 at 77° F and shall be capable of passing the flexibility test as prescribed by ASTM D-1737 using an 8mm diameter mandrel. The coating shall have a minimum tensile strength of 2,500 psi and a recoverable elongation of 30% minimum. It shall have good impact resistance and shall be able to bridge up to 1/8 inch settling crack, which may take place in the concrete structure, without damage to the coating. The coating shall be capable of repair at any time during its life.
4. The coating shall be resistant to attack from the following: oxidizing agents such as bleaches, sulfuric, acetic, hydrochloric, phosphoric, nitric, chromic, oleic, and stearic acids; sodium and calcium hydroxides, ammonium, sodium, calcium, magnesium, and ferric chlorides; ferric sulfate, petroleum oils and grease, vegetable and animal oils, fats, greases, soaps and detergents. The coating shall be impermeable to sewage gases and liquids and shall be nonconductive to bacterial or fungus growth.
5. Surface Preparation: New concrete shall be aged 30 days. All foreign matter shall be removed from the surface of old concrete using solvents (no alcohol shall be used) if necessary to remove grease. For old concrete, all surfaces to be coated will be sandblasted or water blasted to remove all residue, loose grout, or loose brick. Surface of new concrete shall be washed with ten percent muriatic acid solution and flushed with water to remove lime surfaces which have retained a glossy smooth surface shall be abrasively water blasted, sandblasted, or power wire brushed to produce a satisfactory anchor for the coating. The surface must be dry when applying the coating. Cracks shall be sealed by spraying directly into the crack and then over coating while still tacky. Any steel surfaces in the area to be coated will be prepared and primed as required. After blast cleaning the surface as described above, the surfaces of the concrete shall be dried by air blowing for four hours.
6. Application: The polyurethane coating shall be applied by high pressure airless spray with the two components mixing just before the spray gun. During application the applicators, including any persons in the immediate area, shall wear protective clothing including face masks, and anyone in the manhole during spraying shall be supplied respiration air.

Notes:

1. Pipe size to be determined by design flow.
2. Pumping stations shall conform to the following:
  - a) Pumping capacity to handle design flow with one pump out of service.
  - b) Multiple pumps of equal capacity.
  - c) At least 3 pumps, except that 2 pumps for flow less than 0.10 MGD.
  - d) Pumping stations shall be equipped with:
    - 1) Telemetry equipment capable of transmitting various alarm conditions such as high and low sump, flooded dry well, pump, or power failure, to a central dispatch location.
    - 2) Standby power generating equipment, unless it can be shown that a sustained failure will not cause overflow or flooding.
    - 3) Flow monitoring equipment, such as a meter in the discharge line, pump running time recorders with sump level recorders, or other approved methods. Also, provisions shall be made for facilitating installation of portable gravity flow meters in inflow meters.
  - e) Non-clog type pumps designed for sanitary sewage pumping.
  - f) Force mains sized to limit velocities to around 7 fps for up to 300 ft. in length, to around 5 fps for lengths in excess of 1000 ft. These values are approximate, and final design should be based upon analysis of a system head curve based upon commercially available pumps and pump diameters.

NO.	REVISED	BY	<b>Criteria for Design of Sanitary Sewer Facilities</b>	APPROVED	 CITY ENGINEER RCE-28191
				DATE: 2-2-99	
DRAWN BY: Matt				STANDARD NO. S-1	
CHECKED BY: DJR			CITY OF RIPON		
V:\25_City of Ripon Standards\Standard Specifications\Drawings\Sewer\S-1.dwg					

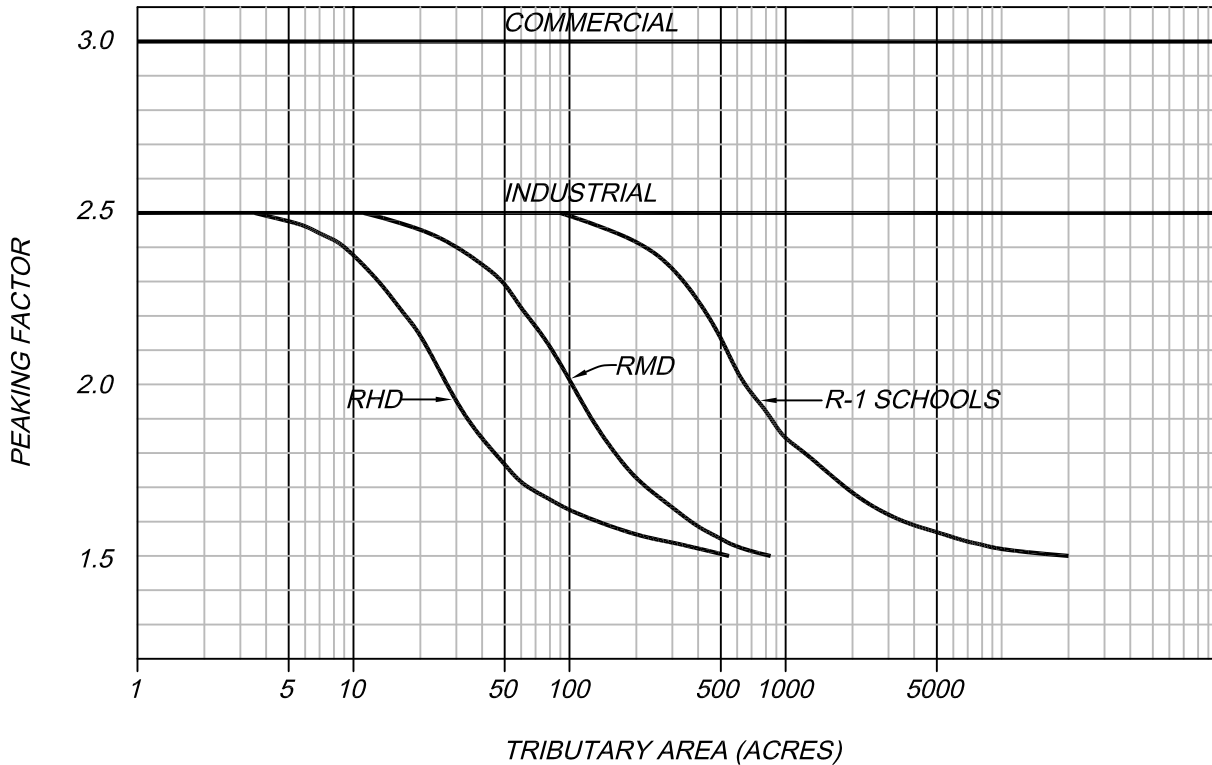

THE TOTAL DESIGN FLOW SHALL BE DETERMINED BY MULTIPLYING THE AVERAGE DESIGN FLOW BY A PEAKING FACTOR FROM THE ABOVE GRAPH.

<u>ZONE</u>	<u>UNITS/ACRE</u>	<u>CAPITA/UNIT</u>
RI (RESIDENTIAL)	4.0	3.0
RMD (MEDIUM DENSITY RES.)	12.0	2.5
RHD (HIGH DENSITY RES.)	16.0	2.5

DESIGN FLOWS

<u>RESIDENTIAL</u>	
AVERAGE FLOW	100 GAL./CAP./DAY
<u>COMMERCIAL</u>	
AVERAGE FLOW	2500 GAL./ACRE/DAY
PEAK FLOW	7500 GAL./ACRE/DAY
<u>INDUSTRIAL (NONSEASONAL)</u>	
AVERAGE FLOW	3500 GAL./ACRE/DAY
PEAK FLOW	8750 GAL./ACRE/DAY

NO.	REVISED	BY	<p align="center"><b>Sanitary Sewer Design Data</b></p>	APPROVED
				 CITY ENGINEER RCE-28191
				DATE: 2-2-99
DRAWN BY: TP			<p align="center"><b>CITY OF RIPON</b></p>	STANDARD NO. S-2
CHECKED BY: DJR				
<small>V:\125_City of Ripon Standards\Standard Specifications\Drawings\Sewer\S-2.dwg</small>				

**DESIGN CRITERIA FOR SANITARY SEWAGE LIFT STATION**

REQUIRED PUMPING CAPACITY

$$Q_p = Q_d F_p \text{ CAP LOTS} / 1440$$

WHERE:  $Q_d$  = DESIGN FLOW FROM STANDARD DETAIL S-2.  
 $F_p$  = PEAKING FACTOR FROM STANDARD DETAIL  
 CAP = CAPITA PER UNIT FROM STANDARD DETAIL  
 LOTS = NUMBER OF LOTS TO BE SERVED BY THE STATION.  
 AND:  $Q_p$  = PUMPING RATE FOR A SINGLE PUMP.

REQUIRED PUMPING WELL VOLUME

$$V_w = 8.02 Q_p / St$$

WHERE:  $Q_p$  = PUMPING RATE IN GPM FOR A SINGLE PUMP.  
 $St$  = STARTS PER HOUR, 6 FOR SUBMERSIBLE PUMPS AND  
 3 FOR ALL OTHERS.  
 AND:  $V_w$  = PIT VOLUME, MINIMUM, IN CUBIC FEET.

NO.	REVISED	BY	<b>Lift Station Design Data</b>	APPROVED
				CITY ENGINEER RCE-28191
DRAWN BY: TP				DATE: 2-2-99
CHECKED BY: DJR			<b>CITY OF RIPON</b>	STANDARD NO. <b>S-3</b>
V:\125_City of Ripon Standards\Standard Specifications\Drawings\Sewer\S-3.dwg				



# SANITARY DESIGN SHEET

JOB NO. \_\_\_\_\_ PAGE \_\_\_\_\_  
DES. BY \_\_\_\_\_ DATE \_\_\_\_\_  
CHKD. BY \_\_\_\_\_ DATE \_\_\_\_\_

## CITY OF RIPON

SUBJECT \_\_\_\_\_  
\_\_\_\_\_  
DESCRIPTION \_\_\_\_\_  
\_\_\_\_\_  
\_\_\_\_\_

STREET/ AREA	FROM MH	TO MH	ACRES*	LOTS	FLOW PER PER (GPD)	AVER. FLOW** (MGD)	AVER. ACCU. FLOW** (MGD)	PEAKING FACTOR	PEAK FLOW (MGD)	PIPE DIA. (IN.)	LENGTH (FT.)	SLOPE (%)	FULL VELOC. (FT/S)	CAP. FULL (MGD)	REMARKS

\*INCLUDING 1/1 \*\*LOT FLOW + 1/1

NO.	REVISED	BY
DRAWN BY: TP		
CHECKED BY: DJR		

### Sanitary Sewer Design Sheet

APPROVED  
  
CITY ENGINEER RCE-28191  
DATE: 2-2-99

# CITY OF RIPON

STANDARD NO. **S-4**

V: 125 City of Ripon Standards | Standard Specifications | Drawings | Sewer | S-4.dwg

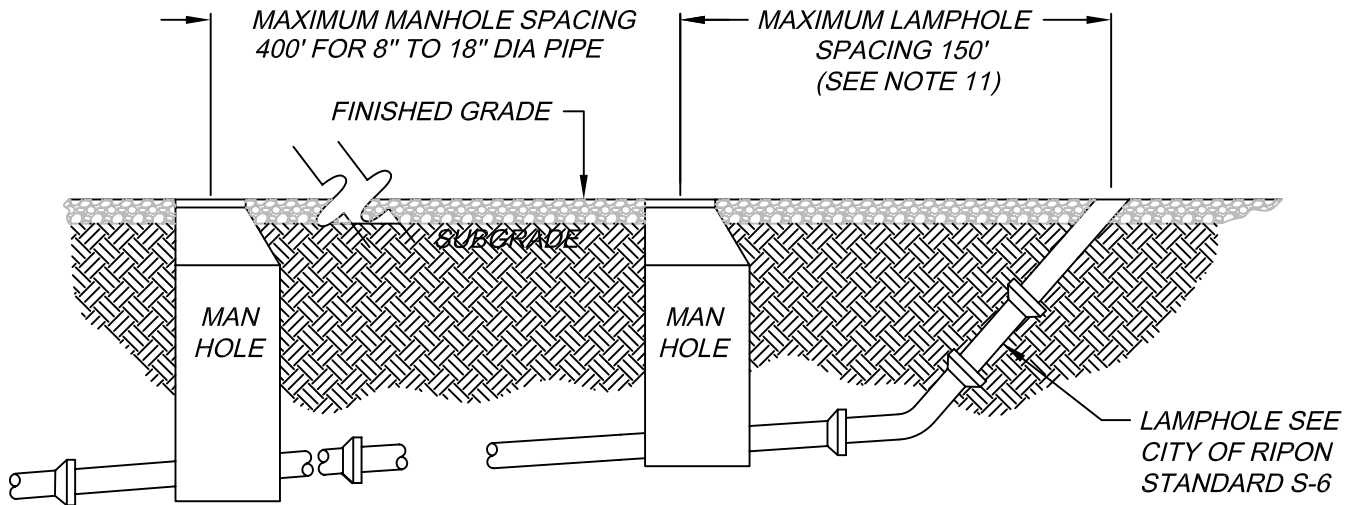

<u>PIPE SIZE</u>	<u>"N"</u>	<u>SLOPE (NOT LESS THAN)</u>
8" DIA	0.009	.0034 FT/FT (SEE NOTE 6)
10" DIA	0.009	.0025 " " "
12" DIA	0.009	.0020 " " "
15" DIA	0.009	.0015 " " "
18" DIA	0.009	.0012 " " "

**NOTES:**

1. THE MINIMUM PIPE SIZE SHALL BE 8" DIAMETER.
2. A MANHOLE SHALL BE INSTALLED AT ALL INTERSECTING STREETS/LINES.
3. ALL CONNECTIONS TO SANITARY SEWERS SHALL BE MADE AT WYES OR BY SAWING A HOLE AND INSTALLING A COLLAR WYE SADDLE.
4. THE DEPARTMENT OF PUBLIC WORKS SHALL BE SUPPLIED WITH AN AS-BUILT PLAN SHOWING LOCATIONS OF ALL LATERALS, BY THE ARCHITECT OR ENGINEER OF PROJECT.
5. MANNINGS "N" SHALL BE NOT LESS THAN 0.009 FOR ALL TYPES OF PIPE.
6. 8" DIA. PIPE AT A SLOPE OF 0.006 FT/FT MINIMUM ON ENDS OF RUNS UP TO 15 CONNECTIONS, OVER 15 CONNECTIONS USE SLOPE PER TABLE ABOVE.
7. PROVIDE A MINIMUM COVER OF 3 FEET. WHERE MINIMUM COVER CANNOT BE OBTAINED, CONCRETE ENCASEMENT OR CAST IRON PIPE SHALL BE USED. SEWER LATERALS SHALL HAVE A MINIMUM OF 4 FEET OF COVER FROM FINISHED GRADE TO TOP OF LATERAL AT BACK OF SIDEWALK.
8. THE USE OF 6" DIAMETER PIPE, NOT EXCEEDING A LENGTH OF 200 FEET AND A SLOPE OF 0.007 FT/FT ON NON-EXTENDABLE RUNS MAY BE PERMITTED BY SPECIAL APPROVAL OF THE CITY ENGINEER. NO MORE THAN 6 HOUSES CAN BE SERVED.
9. PIPE SHALL BE LAID TO GRADE BY MATCHING CROWNS RATHER THAN INVERTS TO INSURE GRAVITY FLOW.
10. CUT SHEETS WILL BE DELIVERED, PRIOR TO CONSTRUCTION, TO THE CITY ENGINEER.
11. LAMPHOLES CAN BE USED FOR SHORT CUL-DE-SAC RUNS WHERE LINE WILL NOT BE EXTENDED, AND ON SHORT RUNS OF PIPE THAT WILL BE EXTENDED, WHERE A MANHOLE WILL BE INSTALLED AT A LATER DATE.

NO.	REVISED	BY	<b>Sanitary Sewer Data</b>	APPROVED
▲	1-2003	MJM		<i>[Signature]</i> CITY ENGINEER RCE-28191
DRAWN BY: MATT				DATE: 2-2-99
CHECKED BY: DJR			<b>CITY OF RIPON</b>	STANDARD NO. <b>S-5</b>
V:\125_City of Ripon Standards \Standard Specifications \Drawings \Sewer \S-5.dwg				

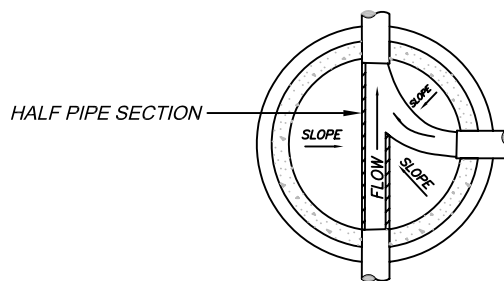
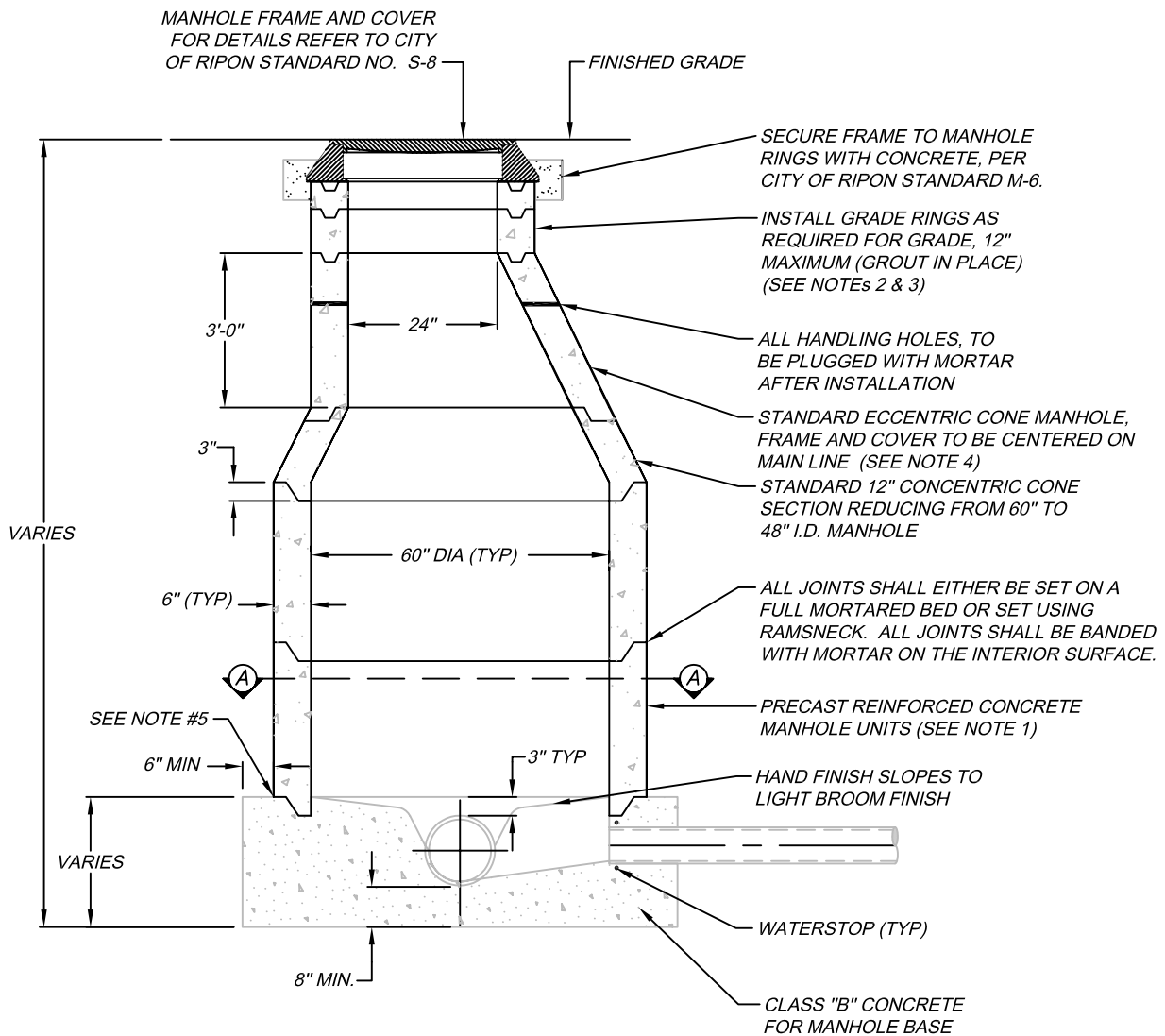

**SECTION A-A**  
MANHOLE SHOWN WITH  
INTERSECTION SEWERS

**NOTES:**

1. PRECAST REINFORCED CONCRETE MANHOLE UNITS SHALL CONFORM TO A.S.T.M. C-478.
2. NUMBER OF GRADE RINGS TO BE KEPT AT A MINIMUM FOR ORIGINAL CONSTRUCTION TO ALLOW FOR FUTURE PAVEMENT ADJUSTMENTS.
3. PRIOR APPROVAL MUST BE OBTAINED FROM EITHER THE CITY ENGINEER OR CITY FIELD INSPECTOR BEFORE INSTALLING MORE THAN 12" OF GRADE RINGS.
4. CONCENTRIC CONES MAY BE USED ONLY WITH PRIOR APPROVAL FROM EITHER THE CITY ENGINEER OR CITY FIELD INSPECTOR.
5. BOTTOM MANHOLE SECTION SHALL BE WET-SET OR SET IN FORMED GROOVE WITH RAMSNECK.

NO.	REVISED	BY	<b>Standard Sanitary Sewer Manhole</b>	APPROVED	 RCE-28191
				CITY ENGINEER	
				DATE: 2-2-99	
DRAWN BY: MATT			<b>CITY OF RIPON</b>	STANDARD NO.	<b>S-6</b>
CHECKED BY: DJR					
V:   25_City of Ripon Standards   Standard Specifications   Drawings   Sewer   S-6.dwg					

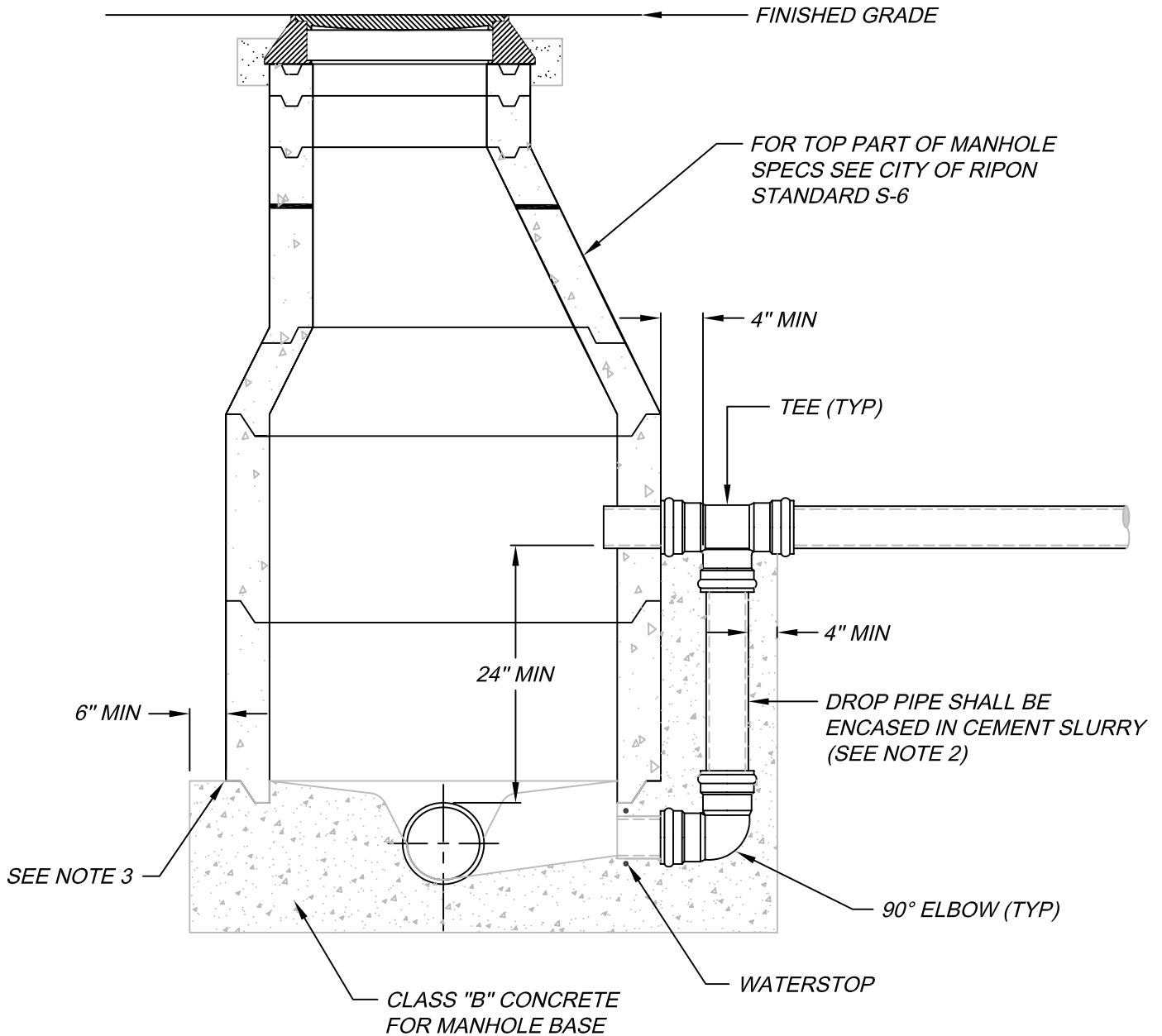

**NOTES:**

1. AN OUTSIDE DROP TYPE MANHOLE SHALL BE USED WHERE THE DIFFERENCE IN ELEVATION BETWEEN THE TOP OF THE MAIN LINE AND THE FLOWLINE OF THE FEEDER PIPE EXCEEDS 24" (2'-0").
2. DROP PIPE TO BE ONE PIPE SIZE LARGER THAN THE INCOMING PIPE.
3. BOTTOM MANHOLE SECTION SHALL BE WET-SET OR SET IN FORMED GROOVE WITH RAMSNECK.

NO.	REVISED	BY	<p><b>Sanitary Sewer Drop Manhole (Exterior Piping)</b></p>	APPROVED	 CITY ENGINEER RCE-28191
				DATE: 2-2-99	
DRAWN BY: MATT				STANDARD NO. <b>S-7</b>	
CHECKED BY: DJR			CITY OF RIPON		
V:\125_City of Ripon Standards\Standard Specifications\Drawings\Sewer\S-7.dwg					

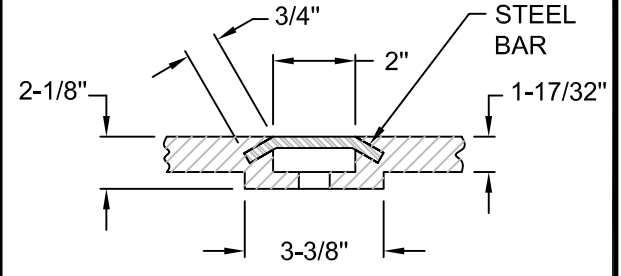
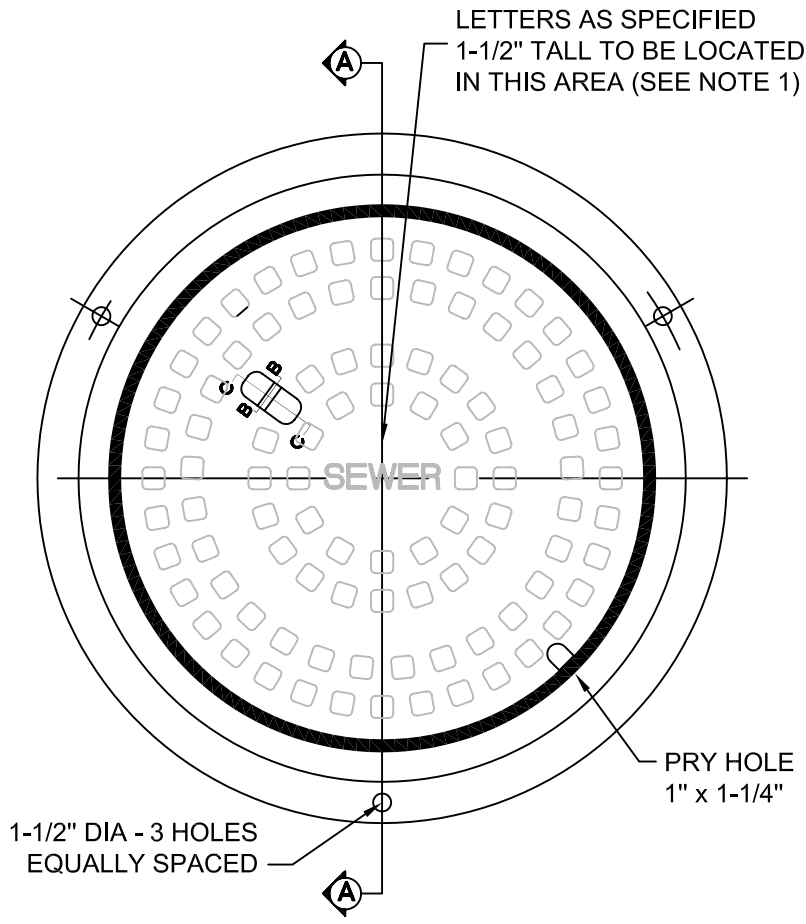

**SECTION B-B**

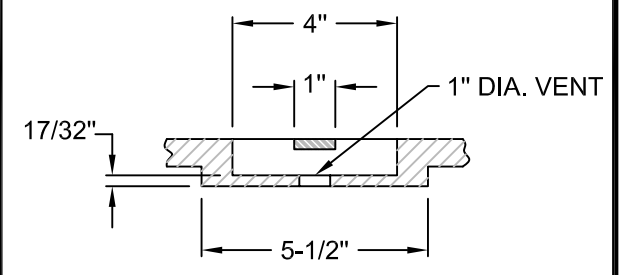

**SECTION C-C**

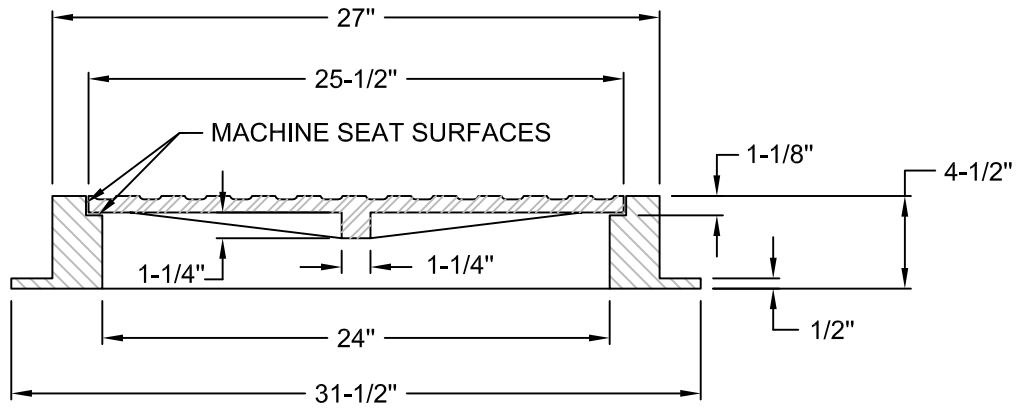

**SECTION A-A**

**NOTES:**

1. SEWER MANHOLES SHALL HAVE THE WORDS "SEWER" CASTED IN THE MANHOLE COVER AT THE LOCATION SHOWN ABOVE.
2. FRAME AND COVER SHALL BE MANUFACTURED OF CAST IRON CONFORMING TO A.S.T.M. A-48 CLASS 30.
3. FRAME AND COVER SHALL BE H-20 RATED.
4. FRAME SHALL WEIGH 140 LBS. MINIMUM AND COVER SHALL WEIGH 130 LBS. MINIMUM.

NO.	REVISED	BY	<p><b>Sanitary Sewer Manhole Frame and Cover</b></p>	APPROVED	<p>CITY ENGINEER RCE-28191</p>
				DATE: 2-2-99	
				STANDARD NO. <b>S-8</b>	
DRAWN BY: MCP			<p><b>CITY OF RIPON</b></p>		
CHECKED BY: DJR					
V:\25_City of Ripon Standards\Standard Specifications\Drawings\Sewer\S-8.dwg					

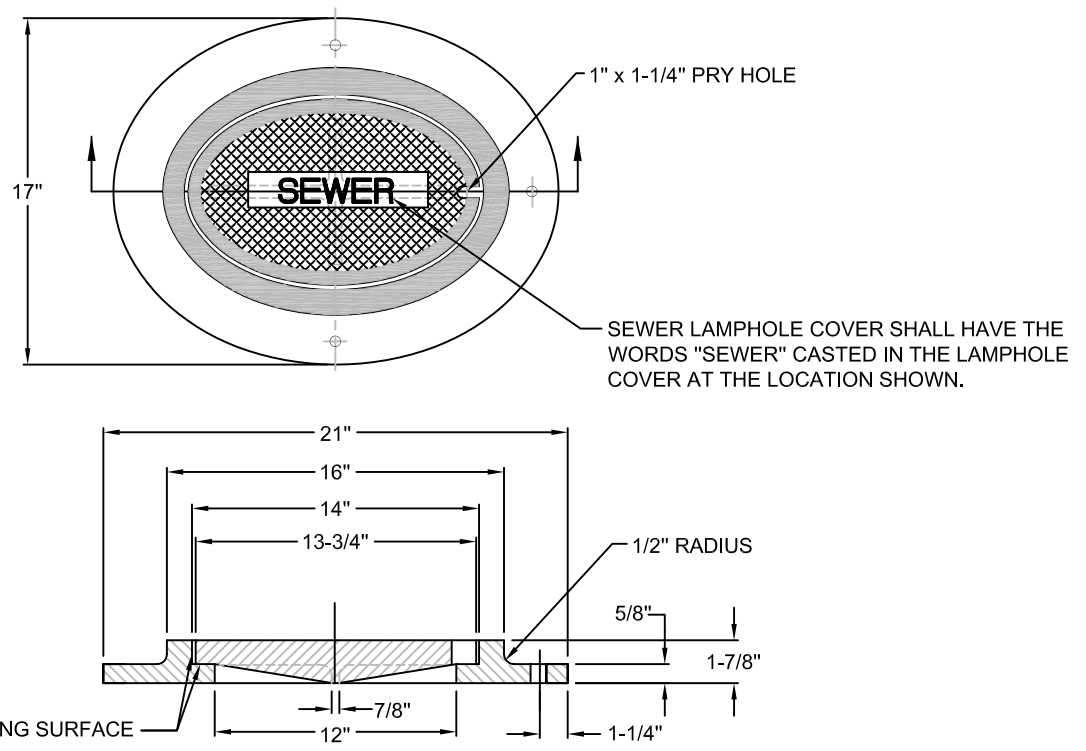
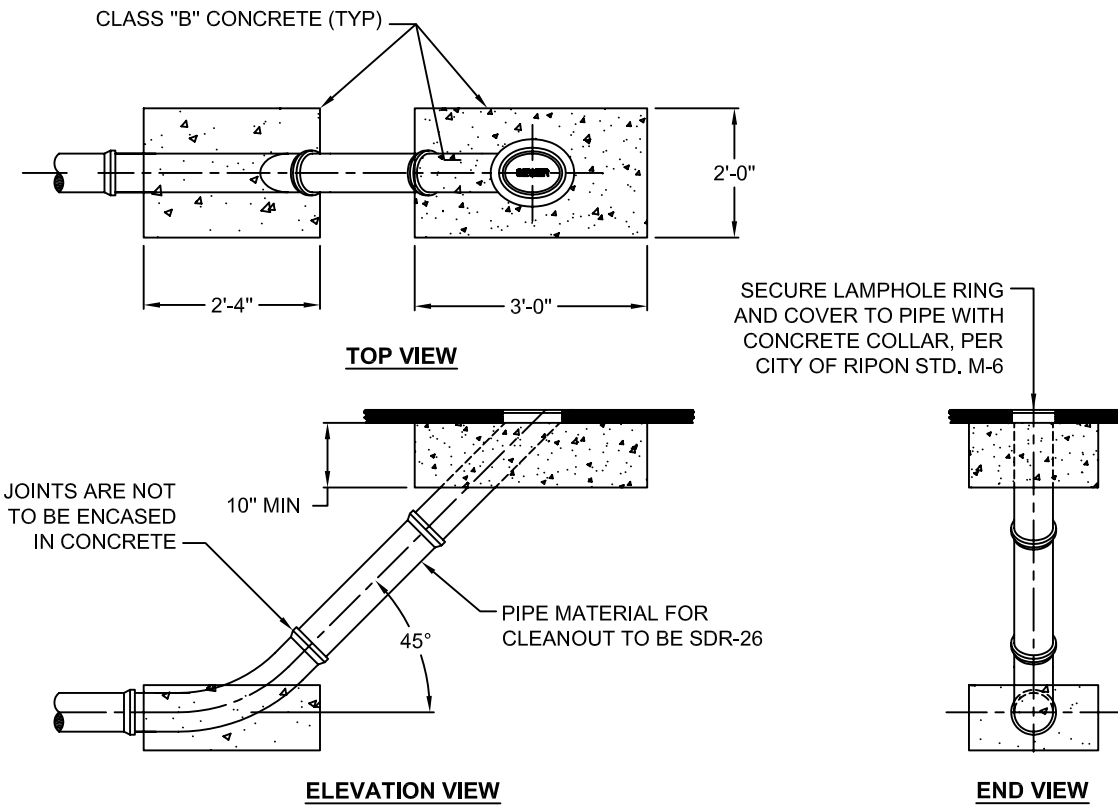

- NOTES:**
1. FRAME AND COVER SHALL BE MANUFACTURED OF CAST IRON CONFORMING TO A.S.T.M. A-48-30.
  2. FRAME AND COVER SHALL BE H-20 RATED.
  3. WEIGHT OF FRAME APPROX. 45 LBS.
  4. WEIGHT OF COVER APPROX. 25 LBS.

NO.	REVISED	BY	<b>Lamphole and Lamphole Ring and Cover Detail</b>	APPROVED
				<i>Dale J. [Signature]</i> CITY ENGINEER RCE-28191
				DATE: 2-2-99
DRAWN BY: MCP			<b>CITY OF RIPON</b>	STANDARD NO. <b>S-9</b>
CHECKED BY: DJR				
V:\25_City of Ripon Standards\Standard Specifications\Drawings\Sewer\S-9.dwg				

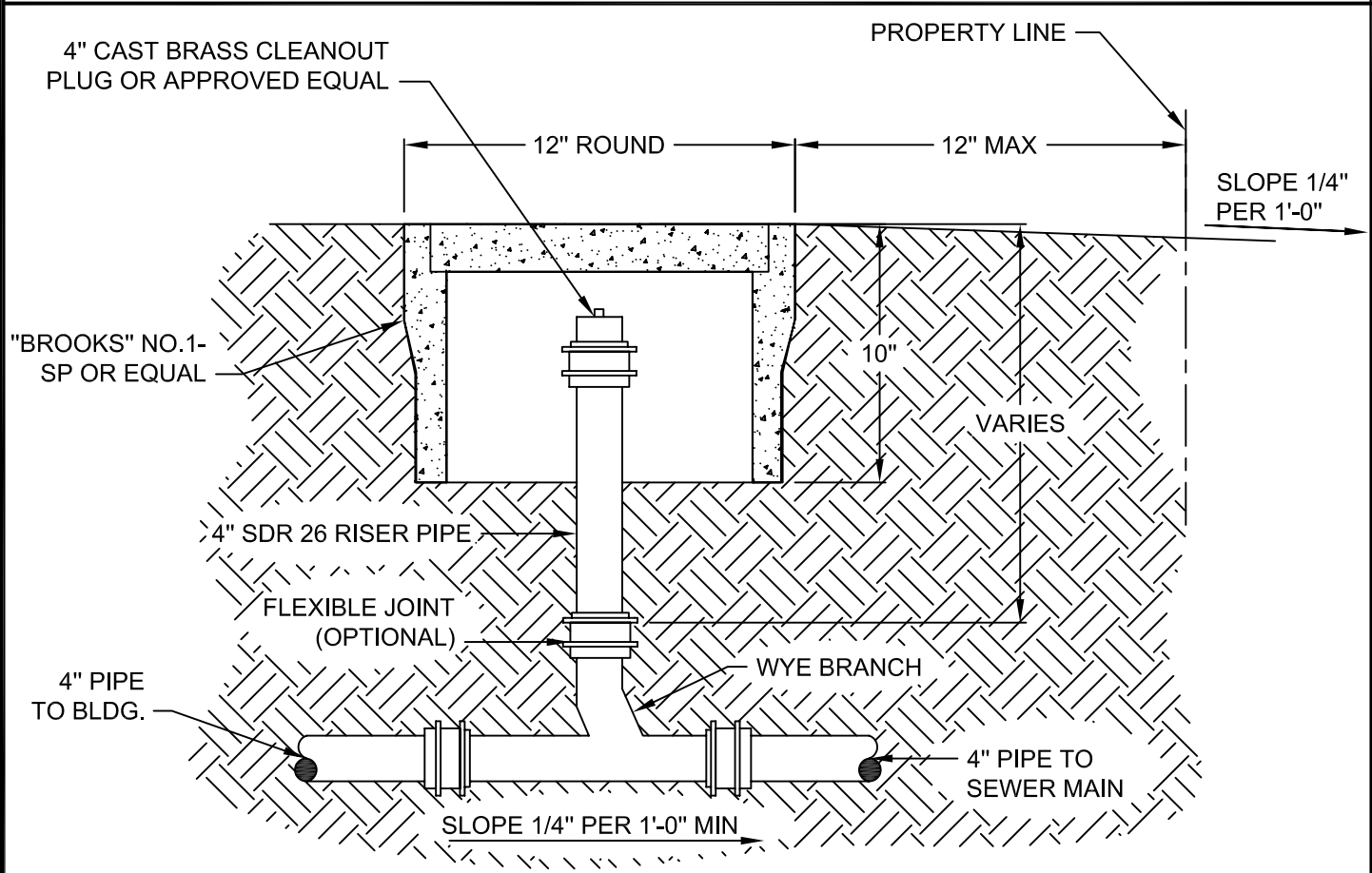
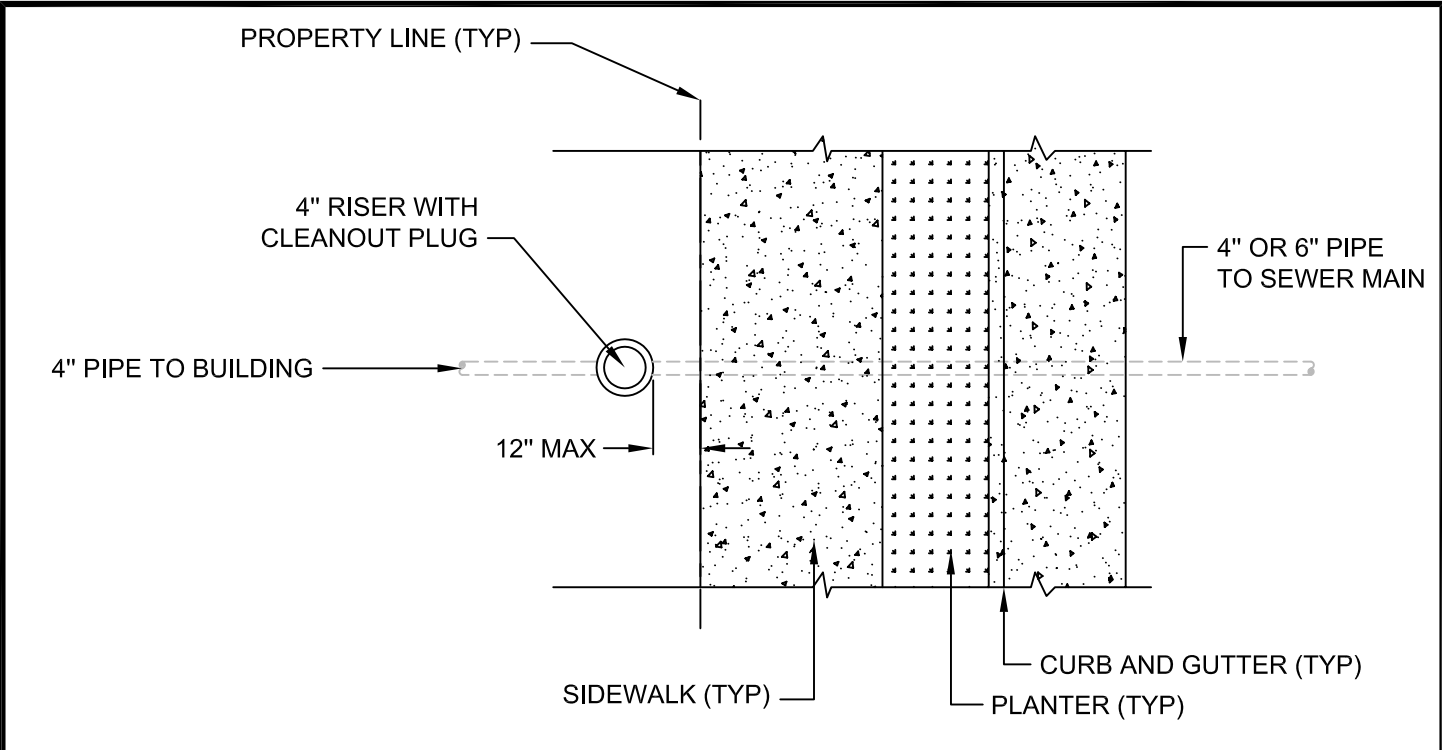

**NOTE:** WHEN MODIFIED CURB, GUTTER, AND SIDEWALK, MEANDERING SIDEWALKS, OR ANY OTHER SPECIAL CASES ARE ENCOUNTERED, CLEANOUTS AND OTHER UTILITY LOCATIONS SHALL BE DETERMINED BY THE ENGINEER AT THE TIME THE SUBDIVISION PLANS ARE SUBMITTED FOR APPROVAL.

NO.	REVISED	BY	<p style="text-align: center;"><i>Cleanout Riser</i></p>	APPROVED
				 CITY ENGINEER RCE-28191
DRAWN BY: MATT				DATE: 2-2-99
CHECKED BY: DJR			<p style="font-size: 24pt; font-weight: bold;">CITY OF RIPON</p>	STANDARD NO. <b>S-10</b>
<small>V:\25_City of Ripon Standards\Standard Specifications\Drawings\Sewer\S-10.dwg</small>				

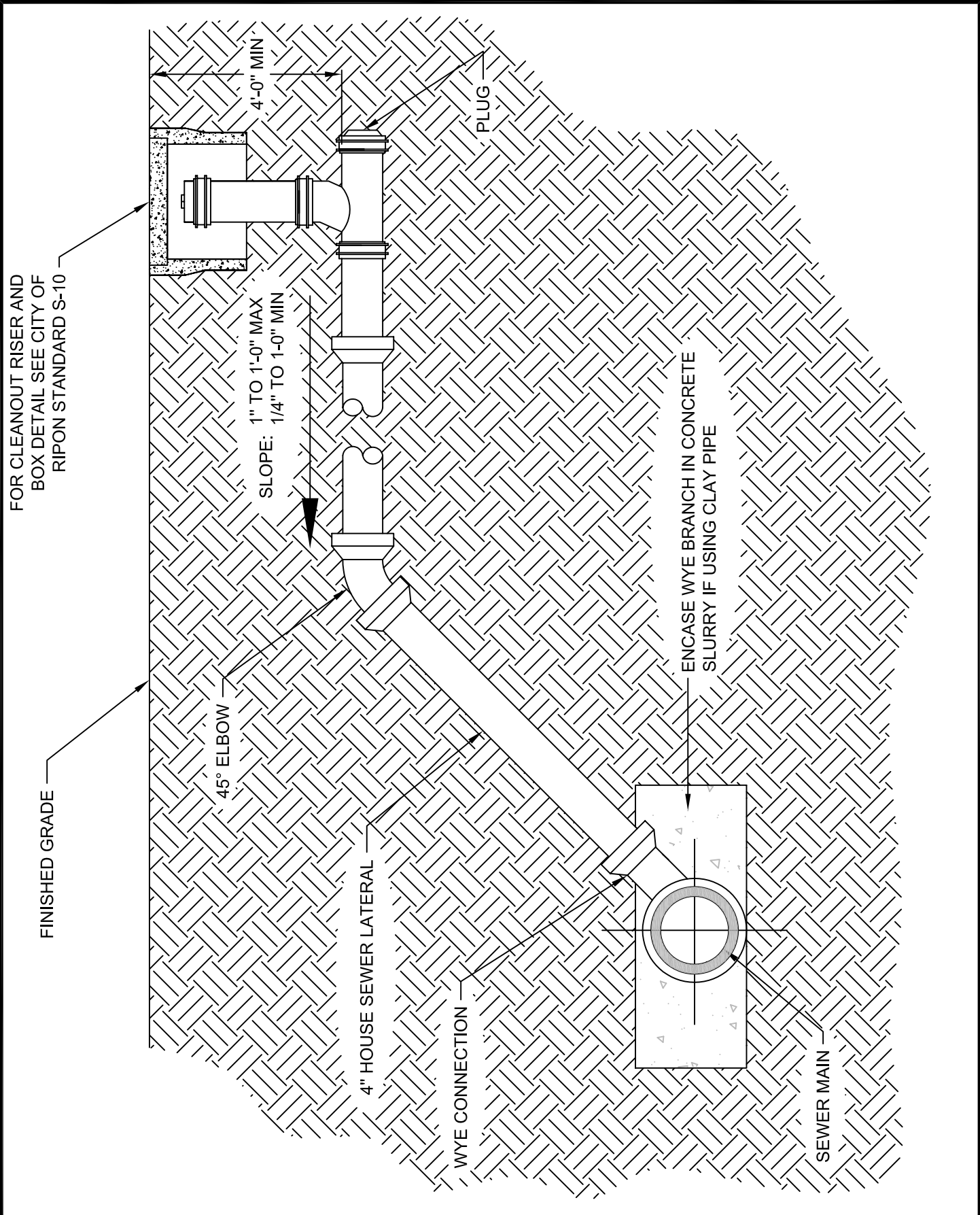

NO.	REVISED	BY
DRAWN BY: MCP		
CHECKED BY: DJR		
V:\25_City of Ripon Standards\Standard Specifications\Drawings\Sewer\S-11.dwg		

**House Lateral  
Detail**

**CITY OF RIPON**

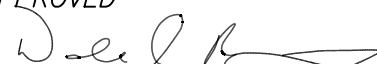
APPROVED  
  
 CITY ENGINEER RCE-28191  
 DATE: 2-2-99  
 STANDARD NO. **S-11**



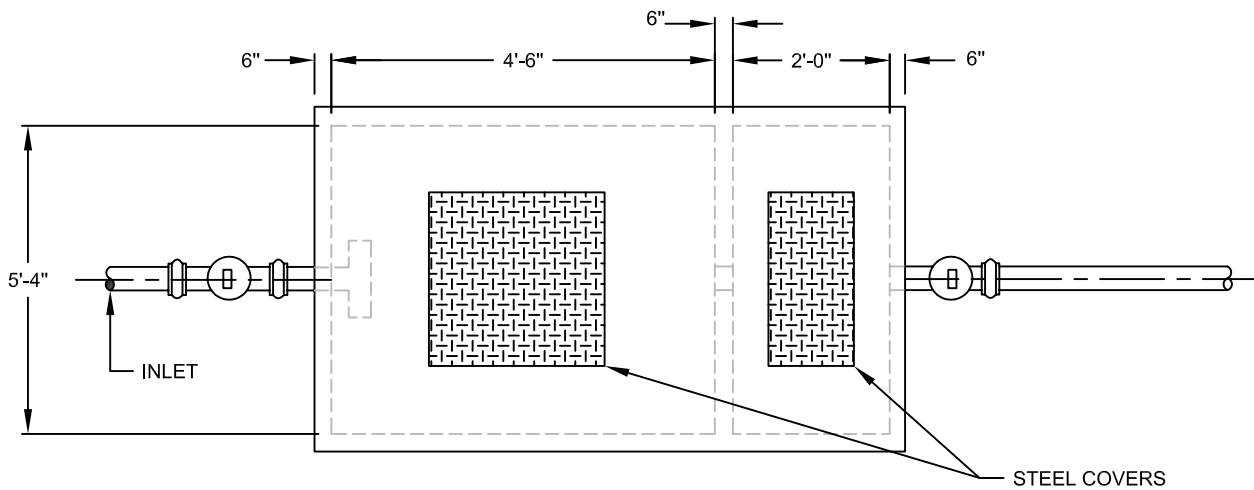

**PLAN VIEW**

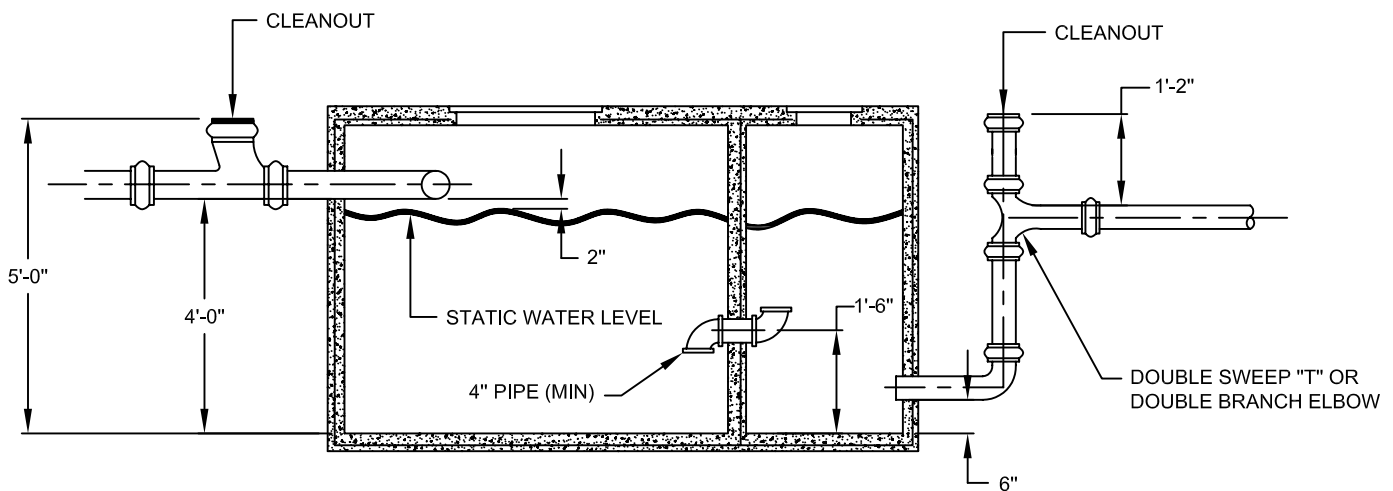

**SECTION**

**NOTES:**

1. DIMENSIONS SHOWN ARE FOR MINIMUM SIZE (750 GALLON) TRAP.
2. EACH UNIT SHALL BE DESIGNED BY A REGISTERED CIVIL ENGINEER AND APPROVED BY THE CITY ENGINEER.
3. STREET INSTALLATION SHALL BE DESIGNED FOR H-20 LOADING.
4. ALL KITCHEN FIXTURES SHALL BE PLUMBED TO FLOW THROUGH TRAP.
5. CONCRETE SHALL BE A MINIMUM OF 3,000 PSI AT 28 DAYS.
6. COVERS SHALL BE STEEL AND SHALL BE GAS TIGHT.
7. ALL WASTE SHALL ENTER TRAP THROUGH THE INLET PIPE ONLY.
8. NO WASTE FROM RESTROOMS SHALL FLOW THROUGH TRAP.

**GREASE INTERCEPTER - INSIDE INSTALLATION**

1. UNIT SHALL BE MOTORIZED STAINLESS STEEL, SELF-CLEANING, GAS TIGHT GREASE AND OIL EXTRACTOR.
2. UNIT SHALL BE INSTALLED AND CONNECTED FOR EASY ACCESSIBILITY FOR INSPECTION, CLEANING, AND REMOVAL OF GREASE.
3. UNIT SHALL BE USED ON ALL DRAINS WHERE GREASE OR OBJECTIONABLE MATERIALS MAY BE DISCHARGED.
4. NO WASTE FROM RESTROOMS SHALL FLOW THROUGH THE INTERCEPTER.
5. UNIT SHALL BE SIZED TO EFFICIENTLY REMOVE GREASE AND OIL.

NO.	REVISED	BY	<b>Typical Grease Trap</b>	APPROVED
				 CITY ENGINEER RCE-28191
				DATE: 2-2-99
DRAWN BY: MATT			<b>CITY OF RIPON</b>	STANDARD NO. <b>S-12</b>
CHECKED BY: DJR				
<small>V:\25_City of Ripon Standards\Standard Specifications\Drawings\Sewer\S-12.dwg</small>				

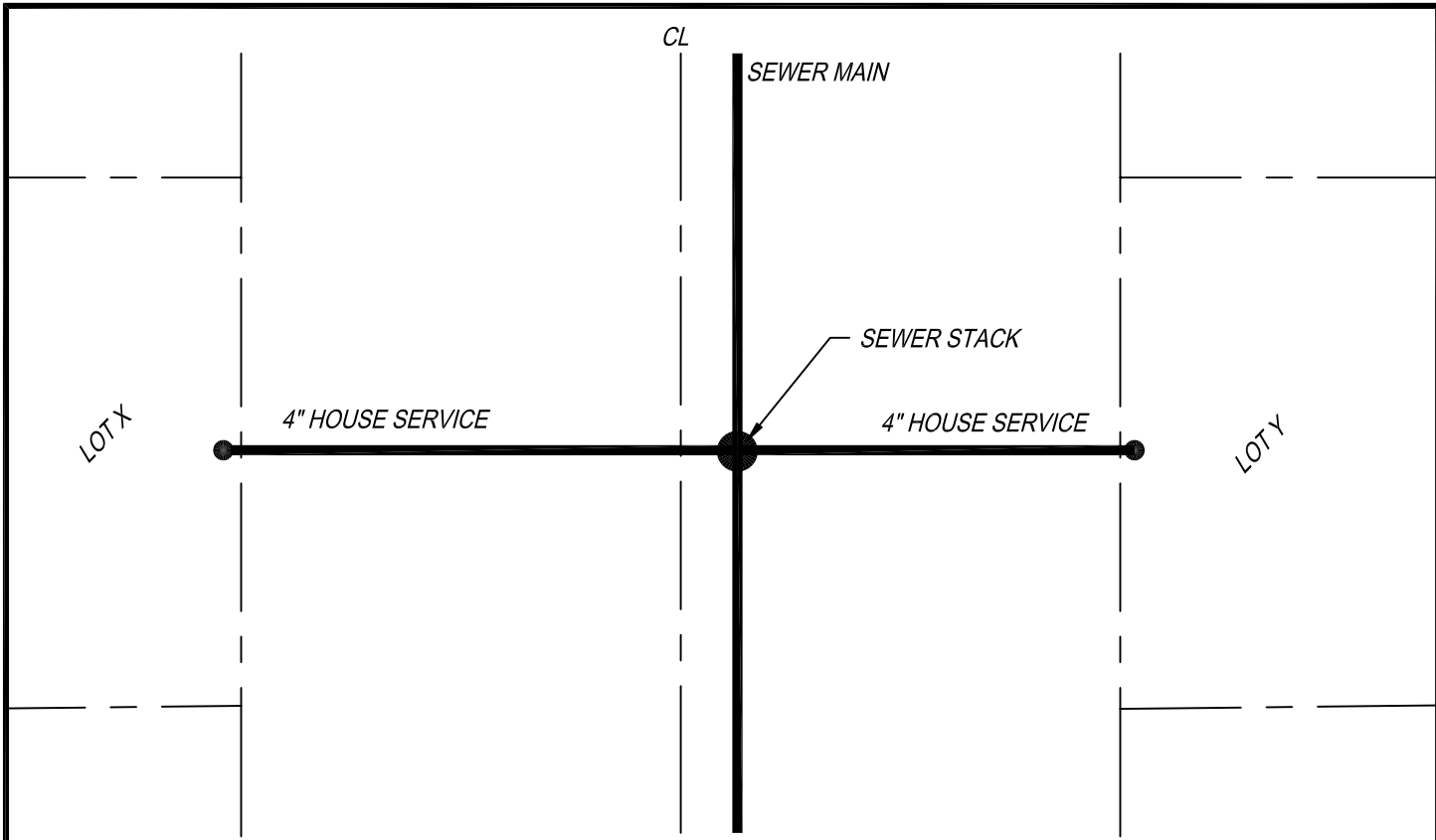

TYPICAL LAYOUT

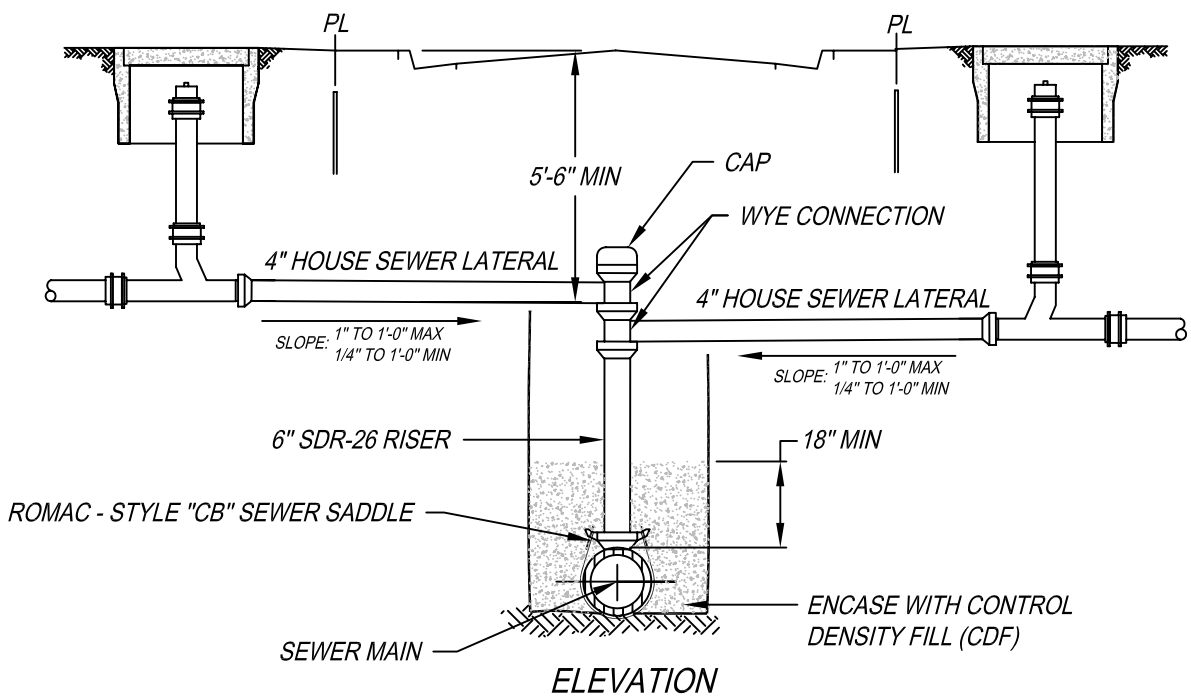

ELEVATION

NO.	REVISED	BY	<b>Sewer Stack House Lateral</b>	APPROVED
				 CITY ENGINEER RCE-28191
				DATE: 2-2-99
DRAWN BY: MCP			<b>CITY OF RIPON</b>	STANDARD NO. <b>S-13</b>
CHECKED BY: DJR				
V: 125, City of Ripon Standards   Standard Specifications   Drawings   Sewer   S-13.dwg				

THIS PAGE  
INTENTIONALLY LEFT BLANK

NO.	REVISED	BY	APPROVED
			 CITY ENGINEER RCE-28191
DRAWN BY: MATT			DATE: 2-2-99
CHECKED BY: DJR			STANDARD NO. <b>S-14</b>
V:\25_City of Ripon Standards\Standard Specifications\Drawings\Sewer\S-14.dwg			
<b>CITY OF RIPON</b>			

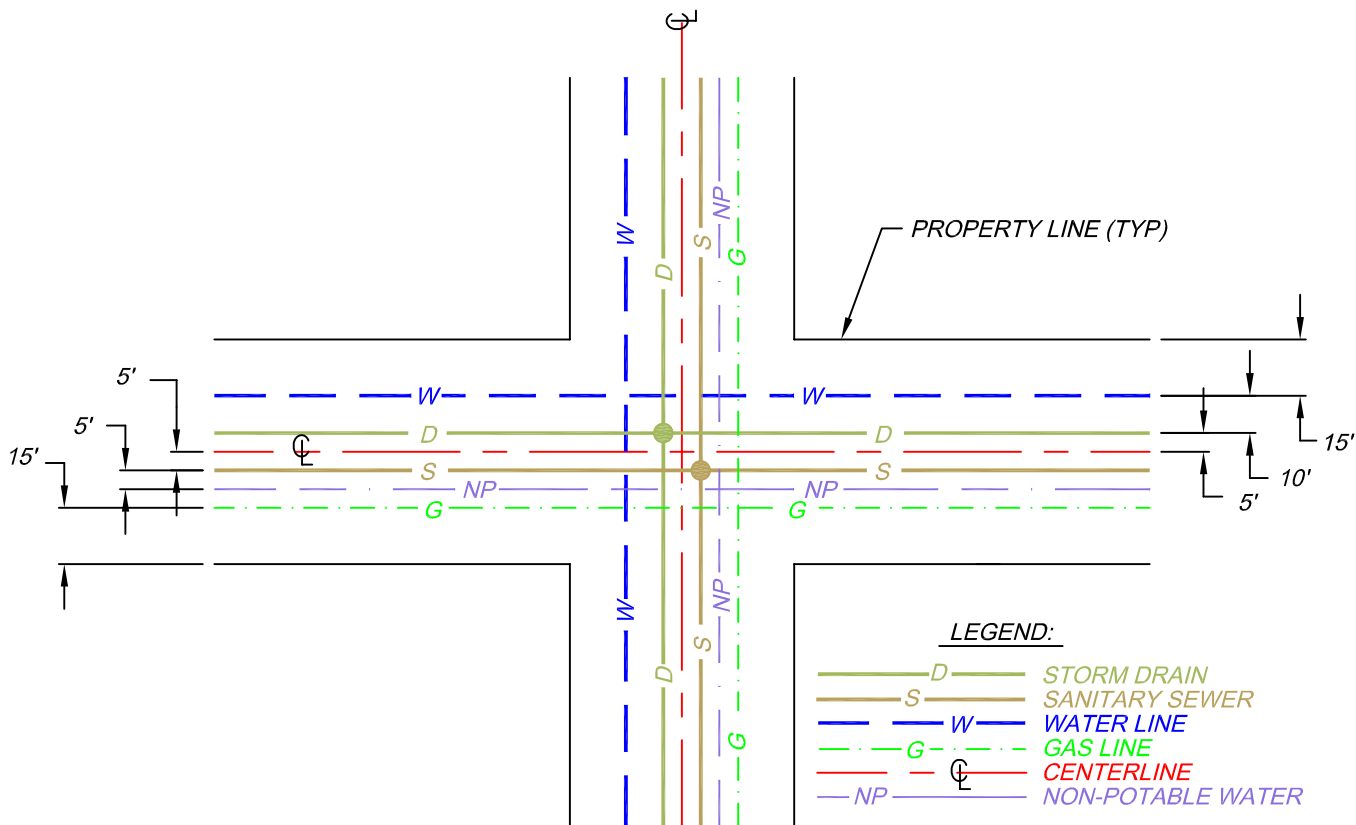

**LEGEND:**

- D — STORM DRAIN
- S — SANITARY SEWER
- - - W - - - WATER LINE
- - - G - - - GAS LINE
- - - CL - - - CENTERLINE
- - - NP - - - NON-POTABLE WATER

**NOTES:**

1. GAS LINE MAY BE PLACED BEHIND SIDEWALK.
2. DEVIATIONS FROM STANDARD LOCATIONS SHOWN MAY BE MADE BY THE CITY ENGINEER.
3. THE ABOVE STANDARD SHALL APPLY WHEREVER WORKABLE, BUT PRIMARILY TO NEW DEVELOPMENTS AND NEW SUBDIVISIONS.
4. SANITARY SEWERS SHALL BE INSTALLED IN STREETS.
5. TELEPHONE, CABLE TV, AND STREET LIGHT FEEDERS SHALL BE LAID IN THE P.U.E. IN NEW DEVELOPMENTS. SEE CITY OF RIPON STANDARD U-9.

NO.	REVISED	BY	<b>Typical Location of Underground Utilities</b>	APPROVED	 CITY ENGINEER RCE-28191
				DATE: 2-2-99	
				STANDARD NO. <b>U-1</b>	
DRAWN BY: TP			<b>CITY OF RIPON</b>		
CHECKED BY: DJR					
V:\125 City of Ripon Standards\Standard Specifications\Drawings\Utilities\U-1.dwg					

***THIS PAGE  
INTENTIONALLY LEFT BLANK***

<i>NO.</i>	<i>REVISED</i>	<i>BY</i>	<i>APPROVED</i>
			<i>CITY ENGINEER RCE-28191</i>
<i>DRAWN BY:</i>			<i>DATE:</i>
<i>CHECKED BY:</i>			<i>STANDARD NO. U-2</i>
<small>V:\125_City of Ripon Standards\Standard Specifications\Drawings\Utilities\U-2.dwg</small>			<b><i>CITY OF RIPON</i></b>

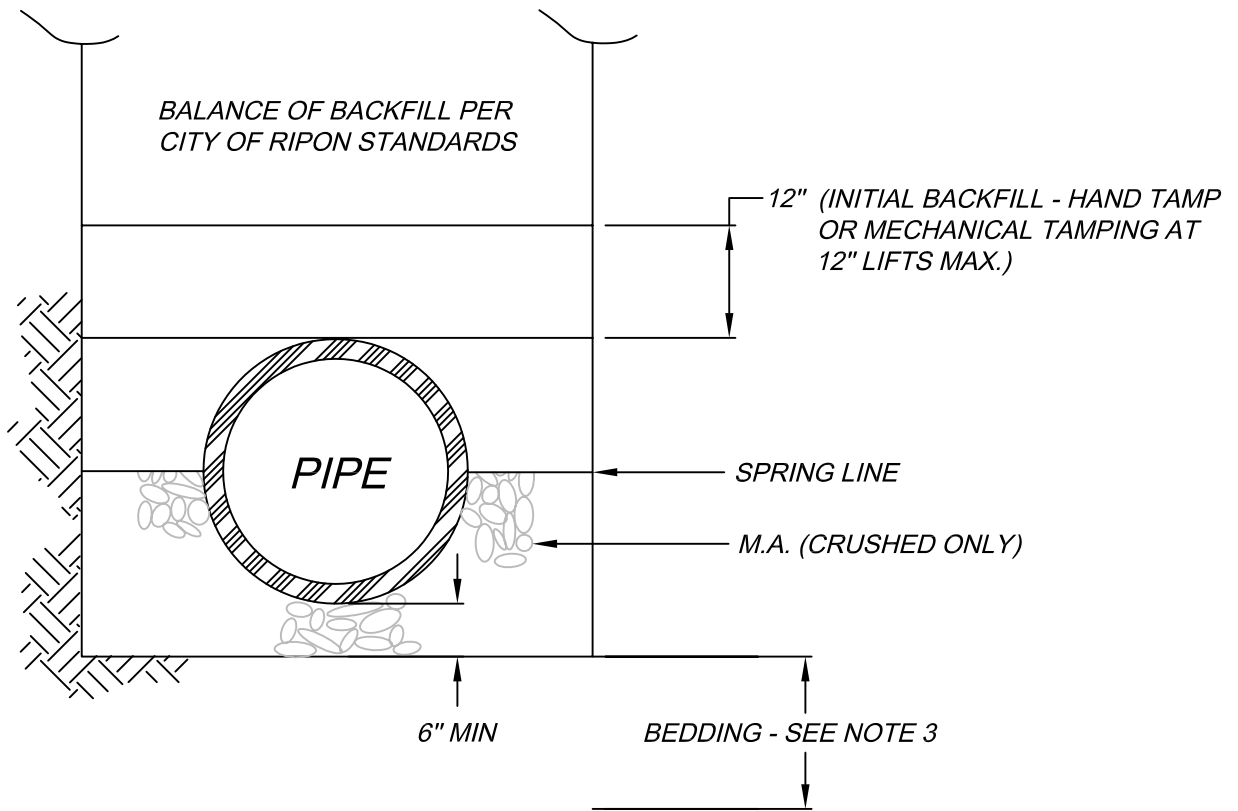

**NOTES:**

1. DEEP TRENCHES ARE DEFINED AS 12 FEET IN DEPTH OR GREATER.
2. ALL EMBEDMENT MATERIALS SHALL CONFORM TO CLASS I, II, OR III SOIL CLASSIFICATIONS AS DESIGNATED IN ASTM D-2321.
3. SELECTED NATIVE MATERIALS CONFORMING TO CLASS I, II, OR III MAY BE USED IN ALL EMBEDMENT MATERIAL ZONES. NATIVE MATERIAL SHALL BE FREE OF ORGANIC MATERIAL, STONES, OR LUMPS EXCEEDING 3" IN GREATEST DIMENSION.
4. ANY AREA AT THE BOTTOM OF THE TRENCH DETERMINED TO BE UNSUITABLE BY THE ENGINEER SHALL BE REMOVED AND REPLACED WITH 6" OF CLASS I, II, OR III MATERIALS AT 95 % RELATIVE COMPACTION (M.R.C.). IN A CASE WHERE THE TRENCH BOTTOM IS UNSTABLE, THE BOTTOM AREA SHALL BE REMOVED AND REPLACED WITH CLASS I OR CLASS II MATERIALS TO A DEPTH DETERMINED BY THE ENGINEER.
5. JETTING WILL NOT BE ALLOWED IN THE EMBEDMENT ZONES, COMPACTION OF EMBEDMENT MATERIALS SHALL CONSIST OF HAND TAMPING AND/OR MECHANICAL TAMPING.

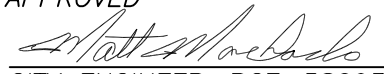
NO.	REVISED	BY	<p><b>Typical Deep Trench Backfill</b></p>	APPROVED	 CITY ENGINEER RCE-58093
					DATE: 3/2002
DRAWN BY: MATT			<p><b>CITY OF RIPON</b></p>	STANDARD NO. <b>U-3</b>	
CHECKED BY: DJR				<small>V:\125_City of Ripon Standards\Standard Specifications\Drawings\Utilities\U-3.dwg</small>	

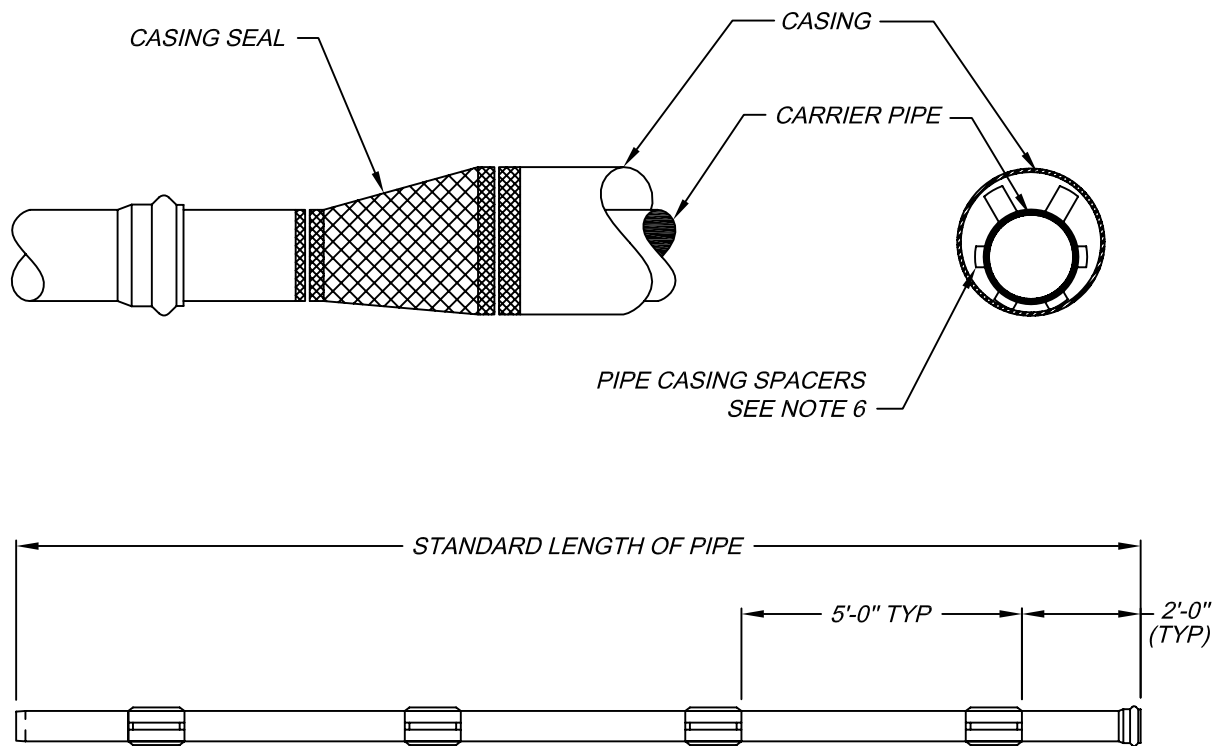

**NOTES:**

1. CASING SHALL BE INSTALLED BY THE DRY BORING AND JACKING METHOD AS SPECIFIED.
2. THE DIAMETER OF THE BORE HOLE SHALL NOT BE MORE THAN 0.1 FOOT GREATER THAN THE OUTSIDE DIAMETER OF THE CASING PIPE.
3. VARIATION IN THE ALIGNMENT AND GRADE OF THE CASING SHALL NOT EXCEED ONE-HALF OF ONE PERCENT OF THE DISTANCE FROM THE JACKING POINT.
4. CASING SHALL BE ASDTM A35, GRADE B, SMOOTH STEEL PIPE, SIZE AND WALL THICKNESS SHALL BE AS INDICATED IN TABLE 1 BELOW.
5. CASING JOINTS SHALL BE WELDED IN ACCORDANCE WITH AWWA C-206, EXCEPT HYDROSTATIC TESTING WILL NOT BE REQUIRED.
6. SPACERS SHALL BE BOLT ON STYLE, TWO PIECE SHELL OF 304 STAINLESS STEEL OF A MINIMUM 14 GAUGE THICKNESS. SHELL SHALL BE LINED WITH RIBBED PVC SHEET OF A 0.090" THICKNESS, WITH OVERLAPS AT EDGES. (CASCADE TYPE CCS SPACERS OR APPROVED EQUAL).
7. WHERE CONDITIONS WARRANT, THE SPACE BETWEEN THE CARRIER PIPE AND THE CASING PIPE SHALL BE FILLED AS DIRECTED BY THE CITY OF RIPON.
8. ENDS OF CASING SHALL BE SEALED WITH A HEAT SHRINKABLE CASING SEAL, (CALPICO MODEL C OR EQUAL).

<b>TABLE 1</b>		
PIPE SIZE AND TYPE	CASING I.D.	WALL THICKNESS
6" SDR-26	10"	0.250
6" C900, 8" SDR-26	12"	0.250
8" C900, 10" SDR-26	14"	0.250
10" C900, 12" SDR-26, 6" VCP	16"	0.250
12" C900, 8" VCP	18"	0.250
14" C905, 15" SDR-26	20"	0.281
18" PS-46, 10" VCP	22"	0.312
16" C905, 18" SDR-26, 12" VCP	24"	0.344
18" C905, 21" PS-46	26"	0.375
15" VCP	28"	0.406
24" PS-46	30"	0.406
18" VCP	32"	0.483

NO.	REVISED	BY	<b>Jack and Boring</b>	APPROVED	 CITY ENGINEER RCE-28191
				DATE: 2-2-99	
DRAWN BY: MCP				<b>CITY OF RIPON</b>	STANDARD NO. <b>U-4</b>
CHECKED BY: DJR			<small>V:\25_City of Ripon Standards\Standard Specifications\Drawings\Utilities\U-4.dwg</small>		

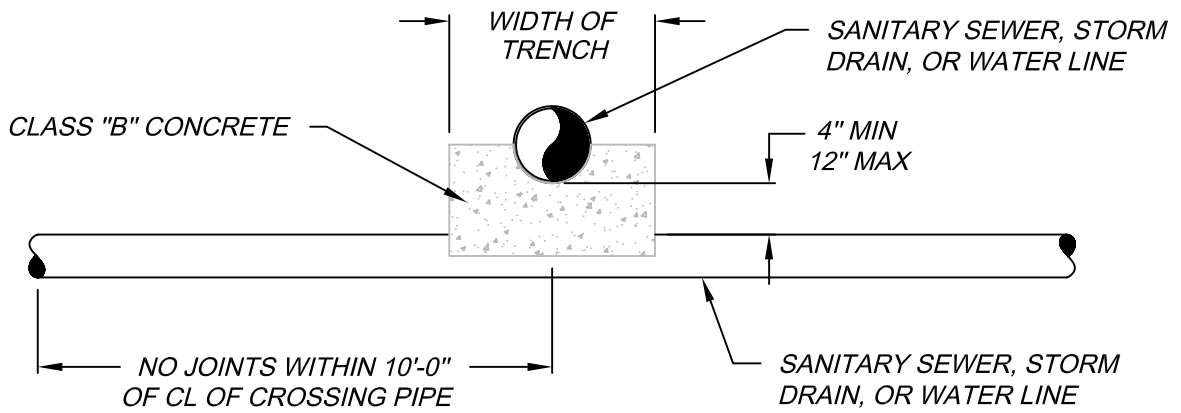

**SECTION VIEW**

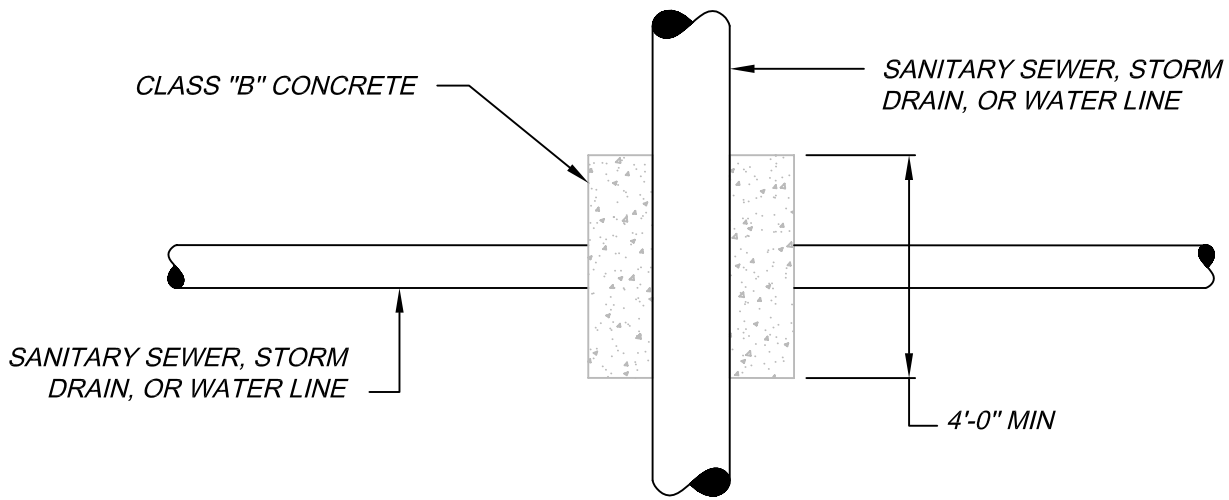

**PLAN VIEW**

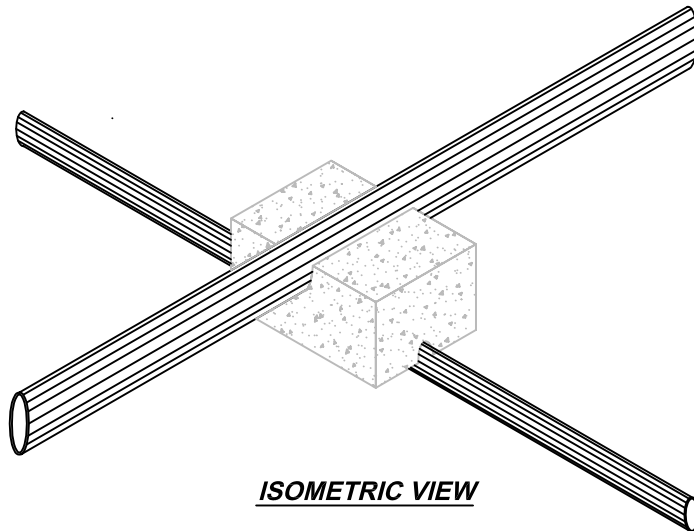

**ISOMETRIC VIEW**

**NOTES:**

- 1. APPLICABLE IN CASES WHERE CLEARANCE IS LESS THAN 12 INCHES.

NO.	REVISED	BY	<b>Concrete Saddle Detail</b>	APPROVED
				<i>[Signature]</i>
				CITY ENGINEER RCE-28191
DRAWN BY: MCP				DATE: 2-2-99
CHECKED BY: DJR			<b>CITY OF RIPON</b>	STANDARD NO. <b>U-5</b>
V:\125_City of Ripon Standards\Standard Specifications\Drawings\Utilities\U-5.dwg				



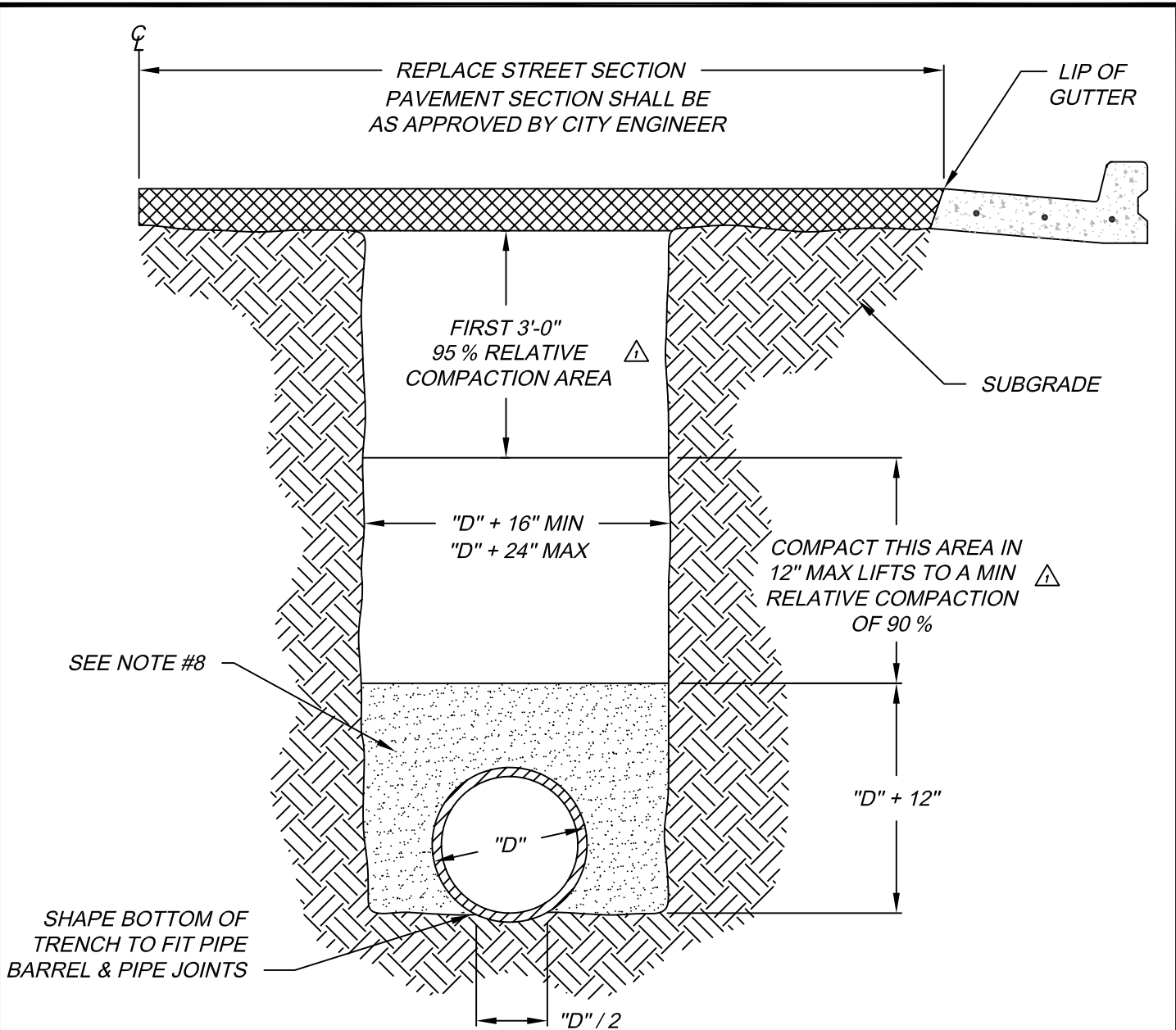

**NOTES:**

1. CONTRACTOR MAY AT THEIR EXPENSE, EXCAVATE 6" BELOW THE BOTTOM OF THE PIPE AND REPLACE WITH SAND OR AGGREGATE SUB-BASE IN LIEU OF SHAPING THE BOTTOM OF THE TRENCH TO FIT THE PIPE BARREL. JOINTS SHALL BE SHAPED IN EITHER CASE.
2. WHEN TRENCH AND EXCAVATION IS IN AN EXISTING PAVED STREET, THE FULL HALF WIDTH OF STREET SHALL BE RE-PAVED WITH AN APPROVED ROADWAY SECTION.
3. TRENCHING IN EASEMENTS AND OTHER AREAS NOT IN THE STREET RIGHT-OF-WAY MAY BE BACKFILLED WITH NATIVE MATERIAL TO 90% RELATIVE COMPACTION.
4. ANY DEVIATION FROM THE ABOVE STANDARD TRENCH SECTION, MUST BE APPROVED BY THE CITY ENGINEER AND SHALL BE DETAILED OUT ON THE IMPROVEMENT PLANS.
5. ALL A.C. SHALL BE LINE CUT WITH A DIAMOND SAW.
6. BACKFILL - CONTROLLED DENSITY FILL (CDF) MAY BE USED IN LIEU OF SPECIFIED BACKFILL METHOD. MINIMUM TRENCH WIDTH MAY BE REDUCED TO 2-1/2" CLEAR OF EACH SIDE OF PIPE, PER SECTION 19-3.066 OF THE CALTRANS STANDARD SPECIFICATIONS.
7. TRANSVERSE TRENCHES WILL BE CONSIDERED ON A CASE BY CASE BASIS, REQUIRING CITY ENGINEER APPROVAL.
8. REFER TO TYPICAL DEEP TRENCH BACKFILL DETAIL (U-3) FOR BACKFILLING AND COMPACTION AROUND PIPE. FOR TRENCHES LESS THEN 12'-0" NATIVE MATERIAL BACKFILL AND BEDDING MAY BE USED.

NO.	REVISED	BY	<b>Existing Street Trench Section</b>	APPROVED
△	1-2003	MJM		 CITY ENGINEER RCE-28191
DRAWN BY: MCP				DATE: 2-2-99
CHECKED BY: DJR			<b>CITY OF RIPON</b>	STANDARD NO. <b>U-6</b>
V:\25_City of Ripon Standards\Standard Specifications\Drawings\Utilities\U-6.dwg				

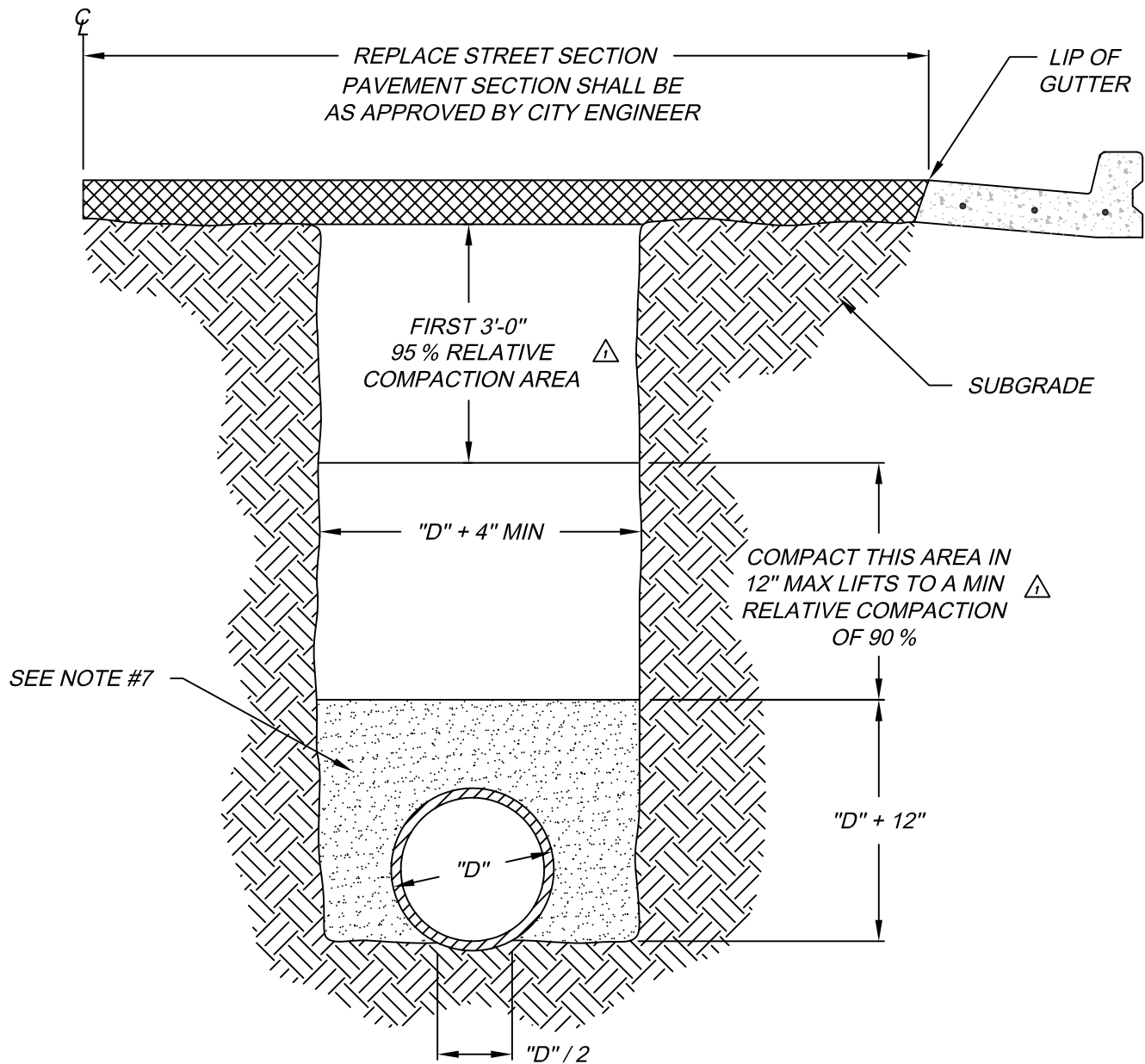

**NOTES:**

1. WHEN TRENCH AND EXCAVATION IS IN AN EXISTING PAVED STREET, THE FULL HALF WIDTH OF STREET SHALL BE RE-PAVED WITH AN APPROVED ROADWAY SECTION.
2. TRENCHING IN EASEMENTS AND OTHER AREAS NOT IN THE STREET RIGHT-OF-WAY MAY BE BACKFILLED WITH NATIVE MATERIAL TO 90 % RELATIVE COMPACTION.
3. ANY DEVIATION FROM THE ABOVE STANDARD TRENCH SECTION, MUST BE APPROVED BY THE CITY ENGINEER AND SHALL BE DETAILED OUT ON THE IMPROVEMENT PLANS.
4. ALL A.C. SHALL BE LINE CUT WITH A DIAMOND SAW.
5. BACKFILL - CONTROLLED DENSITY FILL (CDF) MAY BE USED IN LIEU OF SPECIFIED BACKFILL METHOD. MINIMUM TRENCH WIDTH MAY BE REDUCED TO 2-1/2" CLEAR OF EACH SIDE OF PIPE, PER SECTION 19-3.066 OF THE CALTRANS STANDARD SPECIFICATIONS.
6. TRANSVERSE TRENCHES WILL BE CONSIDERED ON A CASE BY CASE BASIS, REQUIRING CITY ENGINEER APPROVAL.
7. REFER TO TYPICAL DEEP TRENCH BACKFILL DETAIL (U-3) FOR BACKFILLING AND COMPACTION AROUND PIPE. FOR TRENCHES LESS THEN 12'-0" NATIVE MATERIAL BACKFILL AND BEDDING MAY BE USED.

NO.	REVISED	BY	<b>Existing Street Trench Section for Pipe 4" and Smaller</b>	APPROVED
△	1-2003	MJM		 CITY ENGINEER RCE-28191
DRAWN BY: MCP				DATE: 2-2-99
CHECKED BY: DJR			<b>CITY OF RIPON</b>	STANDARD NO. U-7
<small>V:\25_City of Ripon Standards \ Standard Specifications \ Drawings \ Utilities \ U-7.dwg</small>				

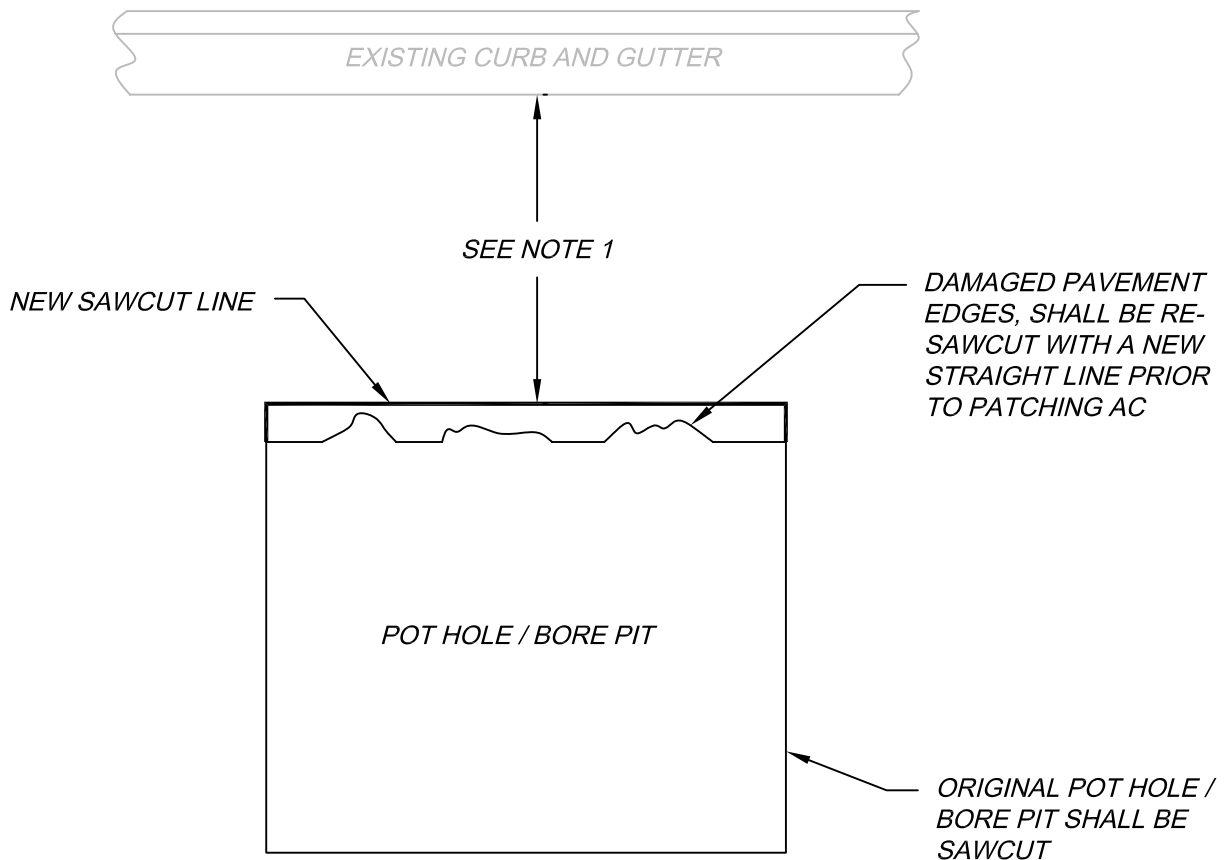

## PLAN VIEW

**NOTES:**

1. IF POT HOLE / BORE PIT IS WITHIN 3'-0" OR LESS OF AN EXISTING CURB AND GUTTER, THE PAVEMENT BETWEEN THE EDGE OF THE TRENCH AND THE EXISTING CURB AND GUTTER SHALL BE REMOVED AND REPAVED WITH THE TRENCH RESTORATION, REGARDLESS OF THE CONDITION OF THE EXISTING PAVEMENT.
2. AC PATCH SHALL MATCH EXISTING AC SECTION OR BE 6" THICK, WHICHEVER IS GREATER

NO.	REVISED	BY	<b>Pot Hole/Bore Pit (Existing Street) Additional Pavement Restoration</b>	APPROVED
				 CITY ENGINEER RCE-2819T
				DATE: 2-2-99
DRAWN BY: TP			<b>CITY OF RIPON</b>	STANDARD NO. <b>U-8</b>
CHECKED BY: DJR				
V:\125_City of Ripon Standards\Standard Specifications\Drawings\Utilities\U-8.dwg				

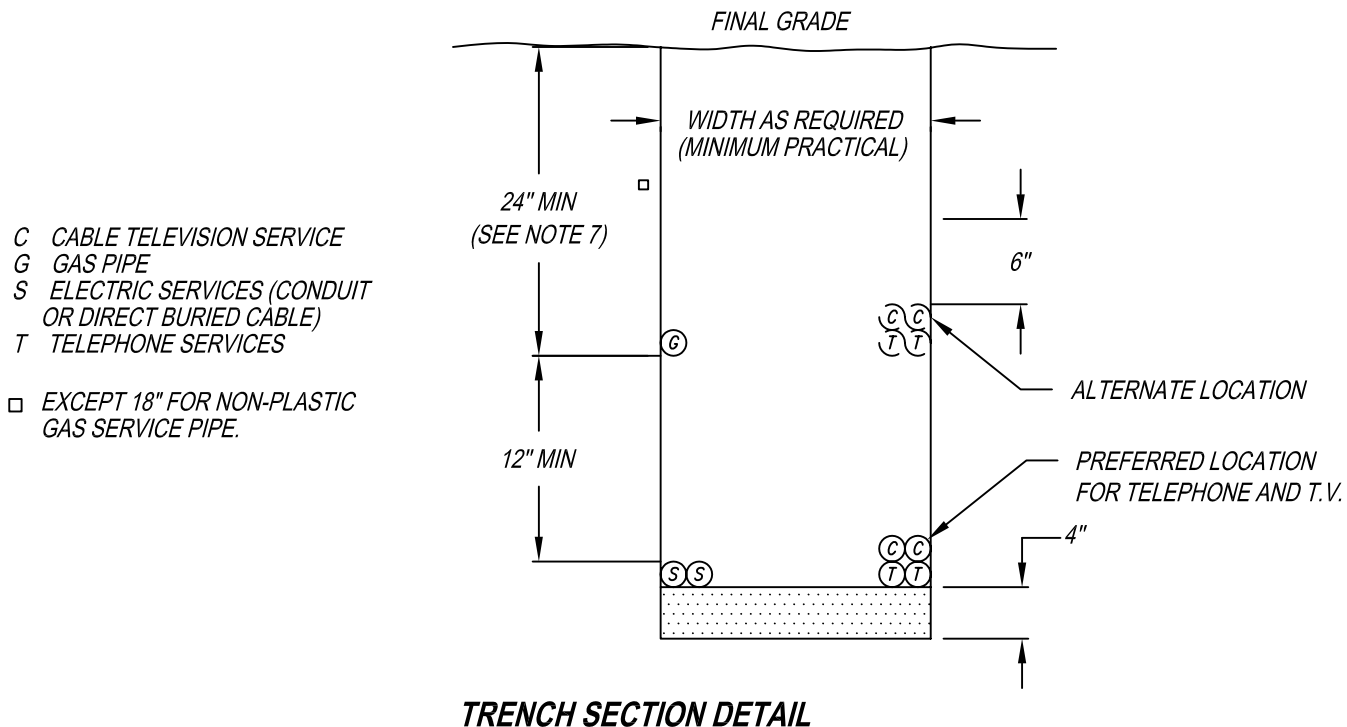
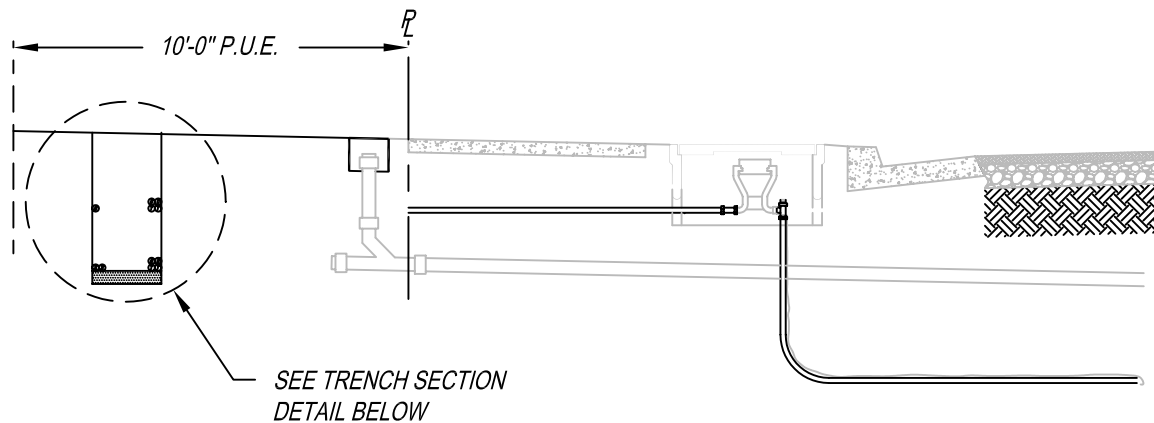

**NOTES:**

1. O DENOTES CABLE OR CONDUIT
2. TRENCH SHALL BE BACKFILLED TO 95 % RELATIVE COMPACTION.
3. UTILITIES SHALL BE PER PUBLIC UTILITY COMPANY REGULATIONS.
4. ALL SERVICE CROSSINGS UNDERNEATH PRIMARY AND SECONDARY ELECTRICAL LINES SHALL HAVE A MINIMUM OF 6" CLEARANCE, IF PLACED BELOW SERVICE LATERALS.
5. A ROCK FREE BACKFILL (SAND OR NATIVE SOIL CONTAINING NOT MORE THAN AN OCCASIONAL ROUNDED ROCK LESS THAN 1/4" DIAMETER) MUST BE PROVIDED FROM A LEVEL 4" BELOW TO 6" ABOVE ALL FACILITIES WITHIN THE TRENCH AREA.
6. DEPTHS AND SEPARATION SHOWN ARE MINIMUMS. GAS FACILITIES SHALL CONFORM TO PROVISIONS OF G.O. 112D AND ELECTRIC FACILITIES TO PROVISIONS OF G.O. 128.
7. ADDITIONAL DEPTH MUST BE PROVIDED TO MAINTAIN THE REQUIRED SEPARATION AND COVER IF GAS FACILITIES CROSS ELECTRIC, TELEPHONE, OR CABLE TELEVISION FACILITIES.
8. ACTUAL LOCATION OF TRENCH SHALL BE DETERMINED BY P.G. & E. AND APPROVED BY THE CITY ENGINEER.

NO.	REVISED	BY	<b>Location of Underground Utilities</b>	APPROVED
				 CITY ENGINEER RCE-28191
DRAWN BY: MCP				DATE: 2-2-99
CHECKED BY: DJR				STANDARD NO. <b>U - 9</b>
<small>V: 125_City of Ripon Standards \ Standard Specifications \ Drawings \ Utilities \ U-9.dwg</small>				<b>CITY OF RIPON</b>

*THIS PAGE  
INTENTIONALLY LEFT BLANK*

NO.	REVISED	BY		APPROVED
				
				CITY ENGINEER RCE-2819T
DRAWN BY: TP				DATE: 2-2-99
CHECKED BY: DJR			<b>CITY OF RIPON</b>	STANDARD NO. <b>U-10</b>
V:\25_City of Ripon Standards\Standard Specifications\Drawings\Utilities\U-10.dwg				

## LIGHTING EQUIPMENT SPECIFICATIONS

### General

Equipment furnished shall be tested and approved, according to procedures set forth by I.E.S. Specifications and shall meet the minimum standards set forth in the American National Standard Practice for Roadway Lighting, latest revision.

Areas with M.I.D. power supply, refer to Stanislaus County Standards for street light details.

### Poles

- a. Steel - hot dipped galvanized steel (ASTM A-123) with 8-foot, high upsweep arms and 2-inch tenon, anchor base type, round tapering shaft. Base shall be welded and the pole will be equipped with hand hole, bolt covers and anchor bolts. Anchor shall be of ASTM A-36 steel plate and shall be designed to withstand the full bending moment of the shaft. Steel castings shall conform to ASTM A27-58 grade 65035. Arms shall be raintight fitting type, single bolt. Gauge shall be 10 for ASTM A-245-64T grade C steel having a yield strength of 33,000 psi before forming, or 11 gauge for 48,000 psi yield strength steel.
- b. Anchor bolts will be supplied meeting ASTM A-307-61T specifications.

### Ballasts

Ballasts shall be of the regulated type unless otherwise specified. Where practicable, they shall be integral with the luminaire. Ballasts shall have a minimum power factor of 90 percent, inrush current shall be less than operating current; shall operate at plus or minus 10 percent rated voltage. Voltage shall be 120, or as specified. Ballasts shall be of the type recommended for the lamp use.

### Lamps

Lamps shall be 120 volt Inductive (QL) of the following manufacturers code numbers, and as shown on drawing no. L-2. The lamps shall be as follows or an approved equal.

55 Watt	I.E.S. Type III	Ordering Information QLRY-GL-3-55-120V-5K
85 Watt	I.E.S. Type III	Ordering Information QLRY-GL-3-85-120V-5K
165 Watt	I.E.S. Type III	Ordering Information QLRY-GL-3-165-120V-5K

NO.	REVISED	BY	<h3 style="margin: 0;">Street and Parking Lot Lighting</h3>	APPROVED	 CITY ENGINEER RCE-28191
				DATE: 2-2-99	
DRAWN BY: MCP				STANDARD NO. <b>L-1</b>	
CHECKED BY: DJR			<b>CITY OF RIPON</b>		
V:\125_City of Ripon Standards\Standard Specifications\Drawings\Lighting\L-1.dwg					

**NOTES:**

1. LUMINAIRE DISTRIBUTION PATTERN SHALL BE BASED ON THE ILLUMINATING ENGINEERING SOCIETY (I.E.S.) CODE FOR STREET AND HIGHWAY LIGHTING.
2. LUMINAIRE SHALL BE A MINIMUM OF A 55 WATT, 3,500 LUMEN UNLESS OTHERWISE SPECIFIED BY THE DIRECTOR OF PUBLIC WORKS.
3. LUMINAIRE OPERATING VOLTAGE SHALL BE 120 VOLTS UNLESS OTHERWISE APPROVED BY THE DIRECTOR OF PUBLIC WORKS.
4. LUMINAIRE SHALL BE QL INDUCTIVE 120 DUAL VOLTAGE BUILT IN BALLAST REACTOR TYPE, AND INDIVIDUAL PHOTO CELL CONTROL TYPE III.
5. WIRING MAY BE OVERHEAD TO POLE IN REAR OF PROPERTY, THRU SIDE YARD EASEMENT, WHERE PRIOR APPROVAL IS OBTAINED FROM THE DIRECTOR OF PUBLIC WORKS.
6. POLES SHALL BE GALVANIZED STEEL TAPERED TUBE.
7. FOUNDATIONS SHALL BE CAST IN PLACE.
8. ALL CONDUIT TO BE USED SHALL BE RIGID METAL OR SCHEDULE 40 P.V.C. AND SHALL BE BURIED TO THE FOLLOWING DEPTH.
  - A. WITHIN SIDEWALK OR PARKWAY AREAS 2'-0" MINIMUM
  - B. WITHIN ROADWAY AREAS 3'-0" MINIMUM
9. THE UNDERGROUND CONDUIT AND ALL METAL PARTS SHALL BE CONTINUOUSLY BONDED AND GROUNDED.
10. MINIMUM RADIUS OF ALL BENDS TO BE 18". ALL BENDS AND/OR OFFSETS SHALL BE MADE WITH FACTORY SECTIONS.
11. ALL SPLICES TO BE APPROVED SOLDERLESS WATERPROOF CONNECTIONS OF PROPER SIZE.
12. ALL EMPTY CONDUITS SHALL BE CAPPED AND A 1/4" NYLON PULL ROPE PROVIDED INSIDE.
13. UNLESS OTHERWISE APPROVED BY THE CITY ENGINEER, A NO. 3-1/2 PULL BOX (STATE STD. ES-8) SHALL BE INSTALLED AT ALL STREET LIGHT STANDARDS. PULL BOXES SHALL NOT BE MORE THAN 250' APART ON LONG RUNS. COVERS SHALL BE INSCRIBED "STREET LIGHTING".
14. WATERPROOF FUSED SPLICED CONNECTIONS SHALL BE INSTALLED IN EACH PULL BOX ADJACENT TO THE LIGHT STANDARD.
15. CONTRACTOR TO STENCIL 2" HIGH BLACK I.D. NO. ON STREET SIDE OF POLE, 9'-0" HIGH ABOVE BACK OF WALK. P.G.&E. OR CITY TO PROVIDE I.D. NO.

LUMINAIRE HIGH PRESSURE SODIUM VAPOR				
STREET TYPE	LAMP SIZE		FACE OF CURB TO LIGHT HEAD	MOUNTING HEIGHT
	WATTAGE	LUMEN		
RESIDENTIAL	55	3,500	4' - 0"	28' - 0"
COLLECTOR	85	6,000	4' - 0"	28' - 0"
ARTERIAL	165	12,000	6' - 0"	32' - 6"

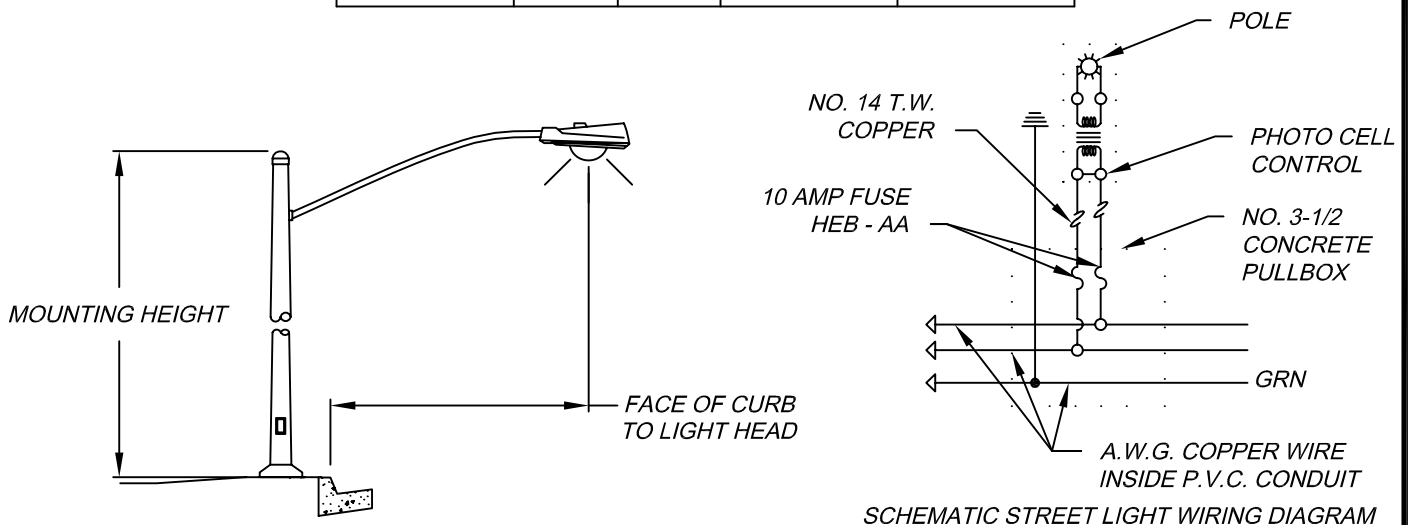

NOTE: AREAS WITH M.I.D. POWER IS REFERED TO STANISLAUS COUNTY STANDARDS FOR STREET LIGHT.  
(IN ALL CASES USE CITY OF RIPON STANDARDS FOR CONDUIT AND PULL BOX CONSTRUCTION DETAILS)

NO.	REVISED	BY	<b>Street and Parking Lot Lighting</b>	APPROVED
				 CITY ENGINEER RCE-28191
				DATE: 2-2-99
DRAWN BY: MCP			<b>CITY OF RIPON</b>	STANDARD NO. L-2
CHECKED BY: DJR				
V:\125_City of Ripon Standards\Standard Specifications\Drawings\Lighting\L-2.dwg				

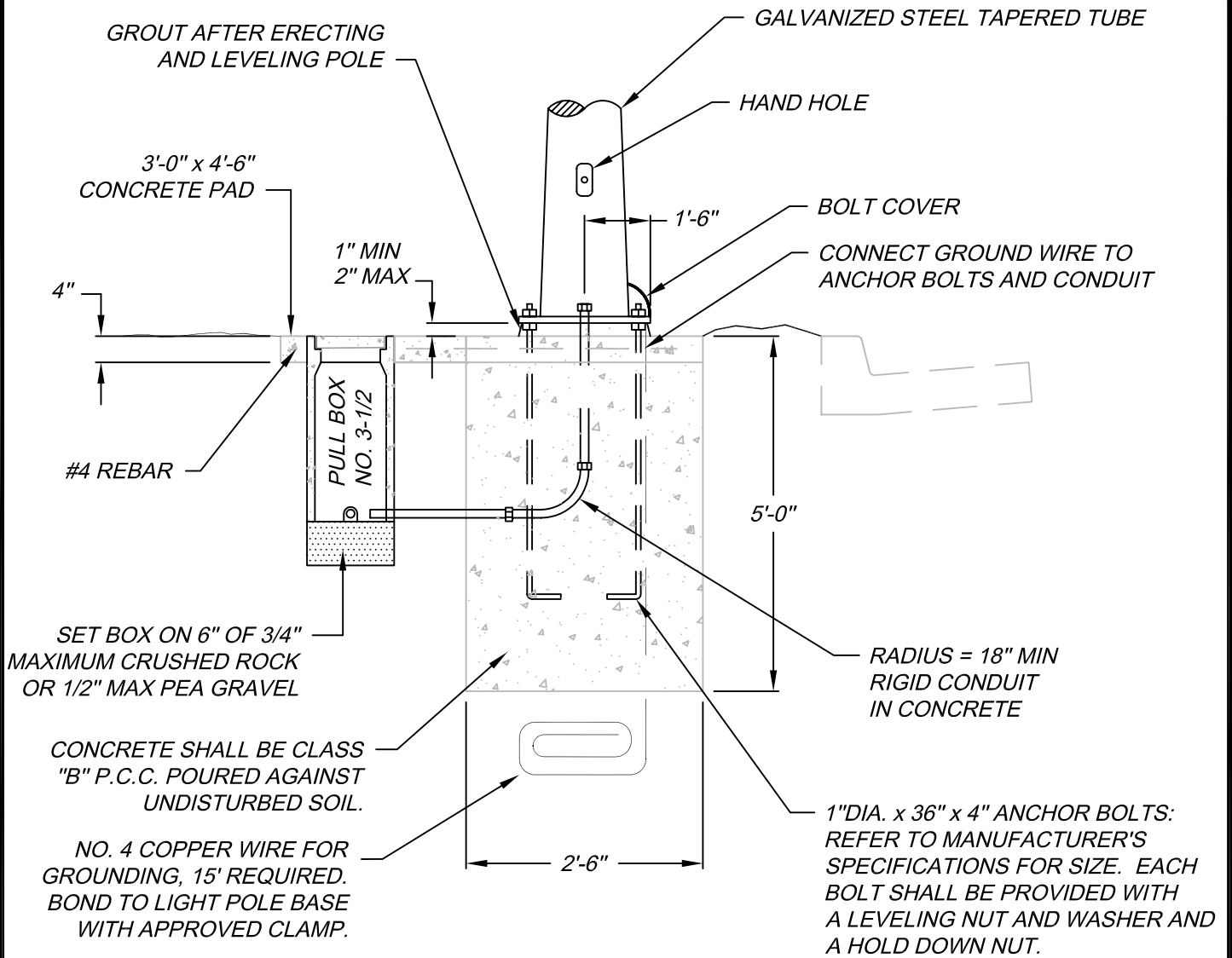

**APPROVED LIGHT STANDARDS**

REFER TO PG&E OR M.I.D. STANDARDS FOR SPECIFIC ACCEPTABLE STREET LIGHTING POLES

NO.	REVISED	BY	<b>Street and Parking Lot Lighting Pole and Base Standards</b>	APPROVED
				 CITY ENGINEER RCE-28191
				DATE: 2-2-99
DRAWN BY: MCP			<b>CITY OF RIPON</b>	STANDARD NO. <b>L-3</b>
CHECKED BY: DJR				
<small>V:\25_City of Ripon Standards\Standard Specifications\Drawings\Lighting\L-3.dwg</small>				



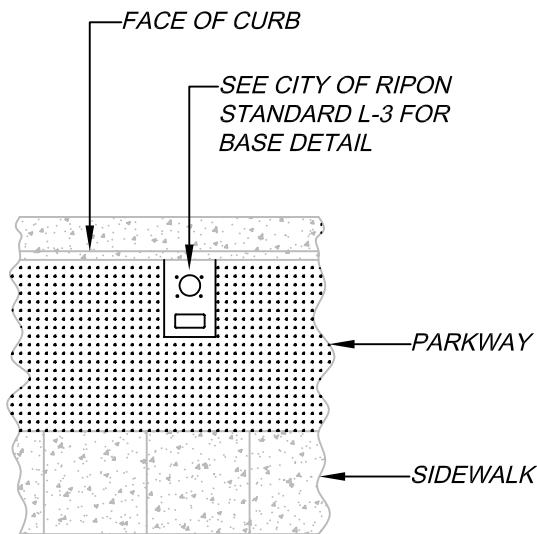

**STANDARD LIGHT POLE LOCATION  
WITH DETACHED SIDEWALK**

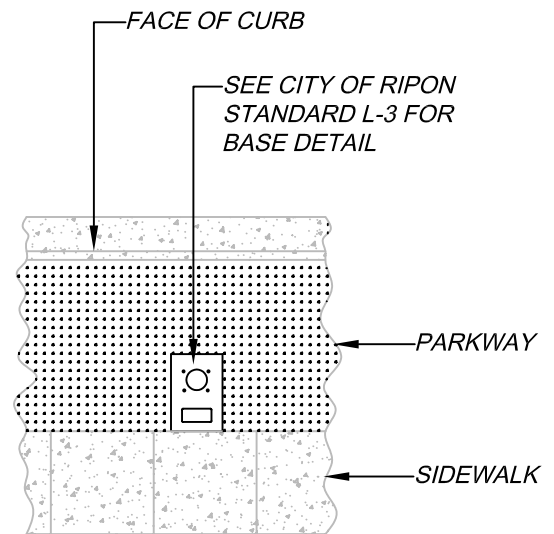

**ALTERNATE LIGHT POLE LOCATION  
WITH DETACHED SIDEWALK**  
(TO BE USED ONLY WHEN STANDARD  
LIGHT POLE LOCATION WILL NOT WORK)

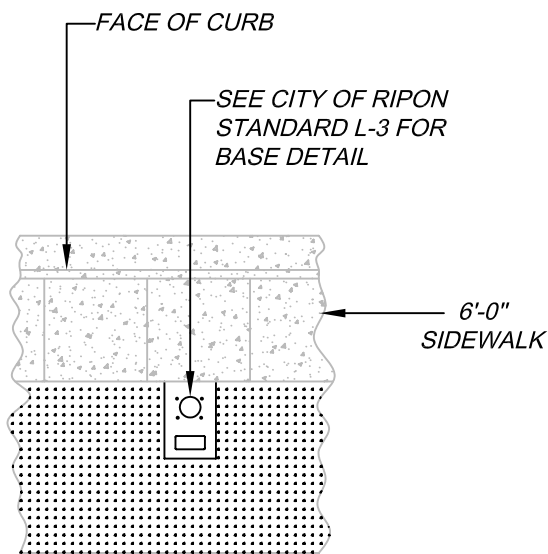

**STANDARD LIGHT POLE LOCATION  
WITH ATTACHED 6'-0" SIDEWALK**

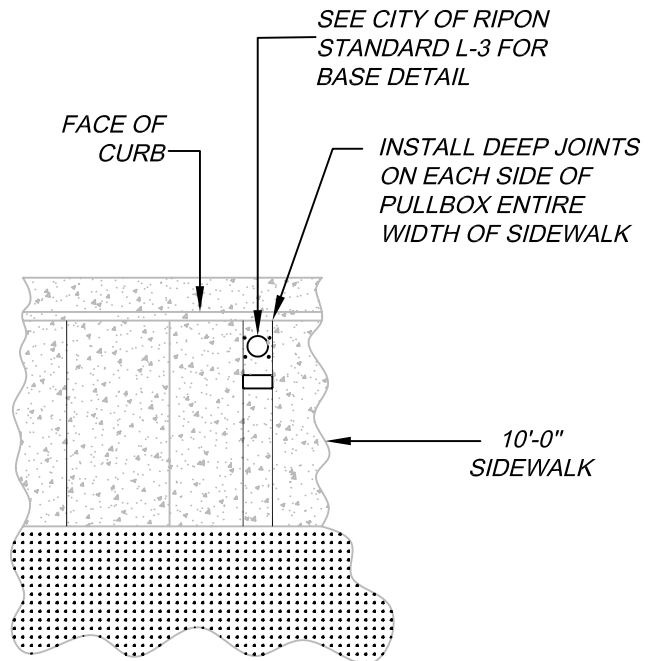

**STANDARD LIGHT POLE LOCATION  
WITH ATTACHED 10'-0" SIDEWALK**

NO.	REVISED	BY
DRAWN BY: MCP		
CHECKED BY: DJR		
V:\25_City of Ripon Standards\Standard Specifications\Drawings\Lighting\L-3a.dwg		

**Street Light  
Pole Base Placement**

**CITY OF RIPON**

APPROVED
CITY ENGINEER RCE-28191
DATE: 2-2-99
STANDARD NO. <b>L-3a</b>

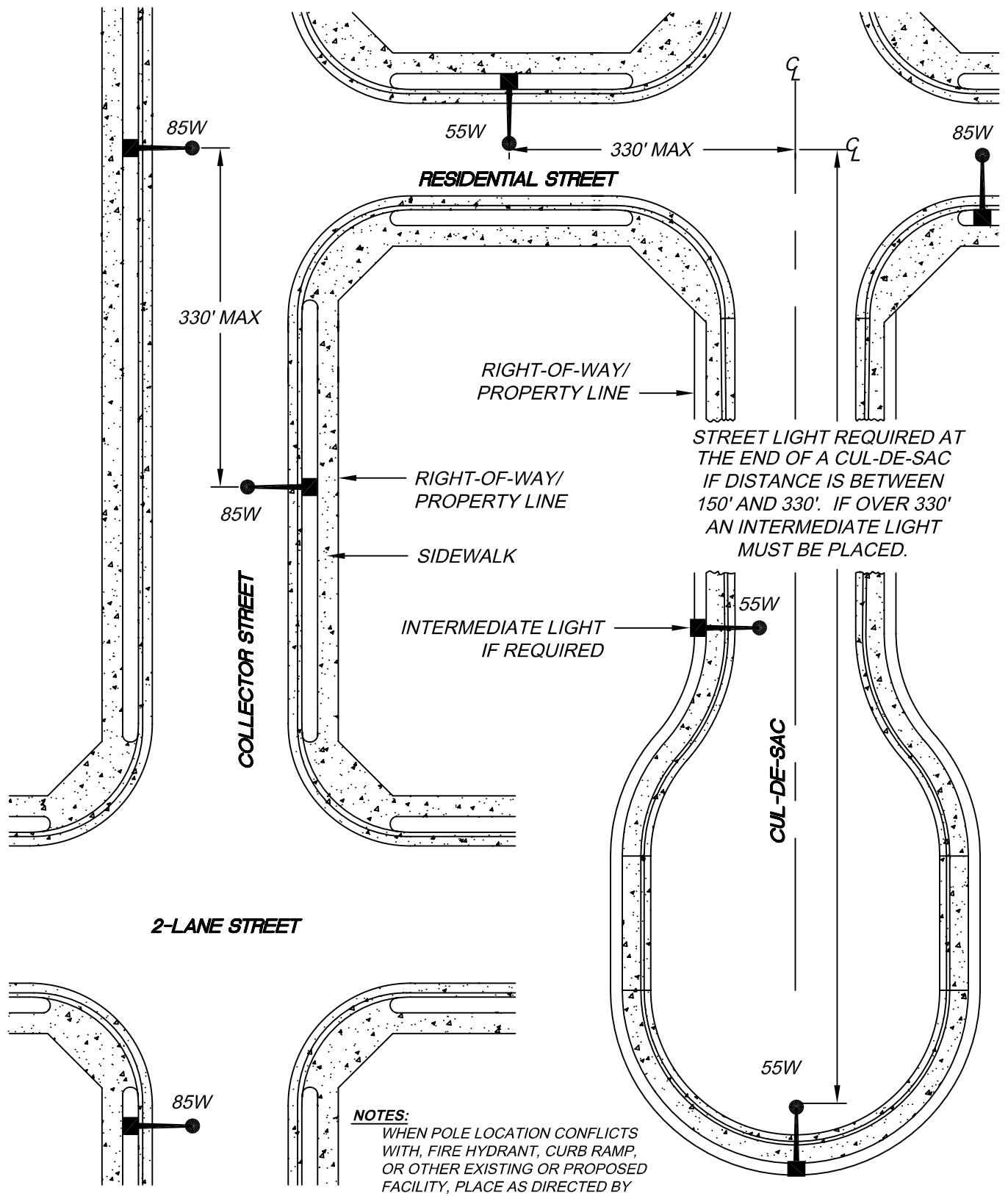

NO.	REVISED	BY
DRAWN BY: MATT		
CHECKED BY: DJR		
V:\125_City of Ripon Standards\Standard Specifications\Drawings\Lighting\L-4.dwg		

**Locations of  
55 and 85 Watt Lights**

**CITY OF RIPON**

APPROVED
<i>[Signature]</i>
CITY ENGINEER RCE-28191
DATE: 2-2-99
STANDARD NO. <b>L-4</b>

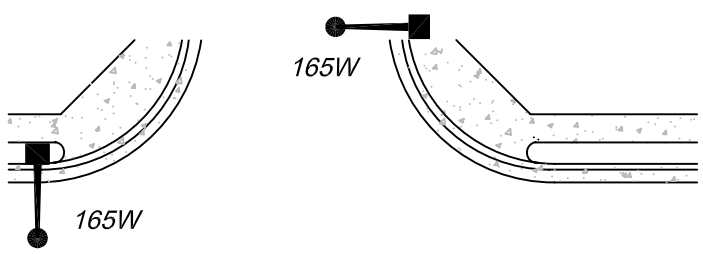

**4-LANE STREET**

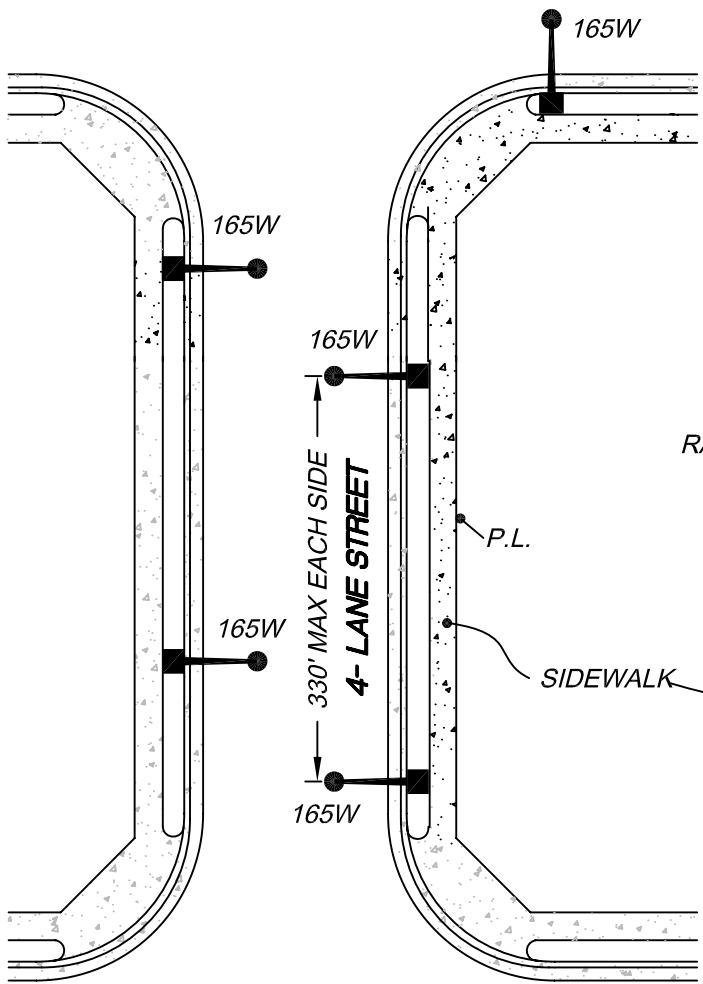

**2-LANE STREET**

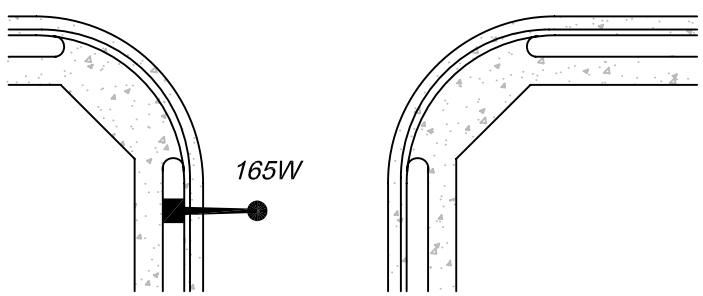

**NOTES:**

WHEN POLE LOCATION CONFLICTS WITH FIRE HYDRANT, CURB RAMP, OR OTHER EXISTING OR PROPOSED FACILITY, PLACE AS DIRECTED BY THE ENGINEER.

NO.	REVISED	BY
DRAWN BY: MATT		
CHECKED BY: DJR		
V:\25_City of Ripon Standards\Standard Specifications\Drawings\Lighting\L-5.dwg		

**Locations of  
165 Watt Lights**

**CITY OF RIPON**

APPROVED

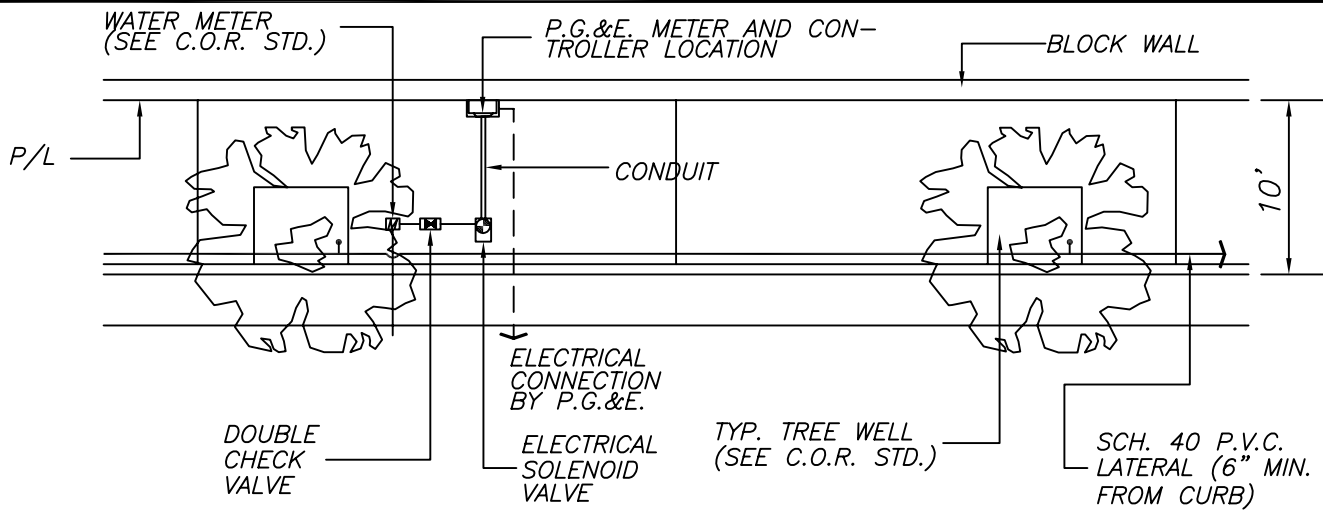
CITY ENGINEER RCE-28191
DATE: 2-2-99
STANDARD NO. <b>L-5</b>



DIAGRAMMATIC IRRIGATION PLAN  
NOT TO SCALE

IRRIGATION LEGEND	
KEY	DESCRIPTION
M	WATER METER INSTALLED BY OTHERS. SEE C.O.R. STANDARD
	DOUBLE CHECK VALVE IN CONCRETE VALVE BOX. SEE C.O.R. STANDARD.
	24 VOLT SOLENOID VALVE. GRISWOLD MODEL NO. 2030 OR EQUAL (IN CONC. VALVE BOX)
	PVC SCH. 40 LATERAL WITH BUBBLER PER C.O.R. STANDARD
	PVC SCH. 80 CONDUIT SEE CABINET DETAIL. C.O.R. STANDARD
	P.G.&E. METER AND RAINBIRD RC-4C CONTROLLER INSTALLED IN A TESCO CABINET WITH CONDUIT. CABINET PER TESCO DWG. NO.COR-112790 OR EQUAL. (SEE DETAIL).

NOTES:

1. THIS PLAN SHALL BE USED WITH C.O.R. STANDARDS.
2. THE ENGINEER OR ARCHITECT SHALL USE THIS PLAN AS A GENERAL GUIDELINE FOR IRRIGATION REQUIREMENTS AS RELATING TO STREET FRONTAGE IMPROVEMENTS WHERE TREE WELLS SHALL BE INSTALLED
3. THE PRIMARY INTENT OF THIS PLAN IS TO DEMONSTRATE THE MINIMUM IRRIGATION DESIGN CALL-OUT REQUIREMENTS OF THE CITY.
4. THE DIAGRAMMATIC IRRIGATION PLAN AS SHOWN ABOVE IS AN EXAMPLE OF MINIMUM REQ'D INFORMATION FOR CONSTRUCTION PURPOSES. THE IRRIGATION PLAN SUBMITTAL SHALL SHOW ALL POINTS OF INSTALLATION AND CONNECTION, AND GIVE DETAILS AS TO HOW INSTALLATION AND CONNECTIONS SHALL BE MADE. PIPES, VALVES, BACKFLOW PREVENTION, WIRING, ETC., SHALL BE PROPERLY SIZED AND INDICATED ON THE SUBMITTED PLANS.
5. PLANS SHALL SHOW ENTIRE PROJECT AREA WITH PROPOSED IRRIGATION SYSTEM, ETC.
6. DETAILS GIVEN ARE DIAGRAMMATIC AND SHALL NOT BE DIRECTLY COPIED ONTO WORKING DRAWINGS. THESE DETAILS SHOW MATERIAL REQUIREMENTS BY THE CITY AND SERVE AS EXAMPLES OF REQ'D INFORMATION FOR INSTALLATION BY A LICENSED LANDSCAPE CONTRACTOR.

NO.	REVISED	BY	<b>Typical Tree Well Irrigation System Requirements</b>	APPROVED
				 CITY ENGINEER RCE-28191
				DATE: 2-2-99
DRAWN BY: MATT			<b>CITY OF RIPON</b>	STANDARD NO. <b>IRR-1</b>
CHECKED BY: DJR				
SCALE: NONE				

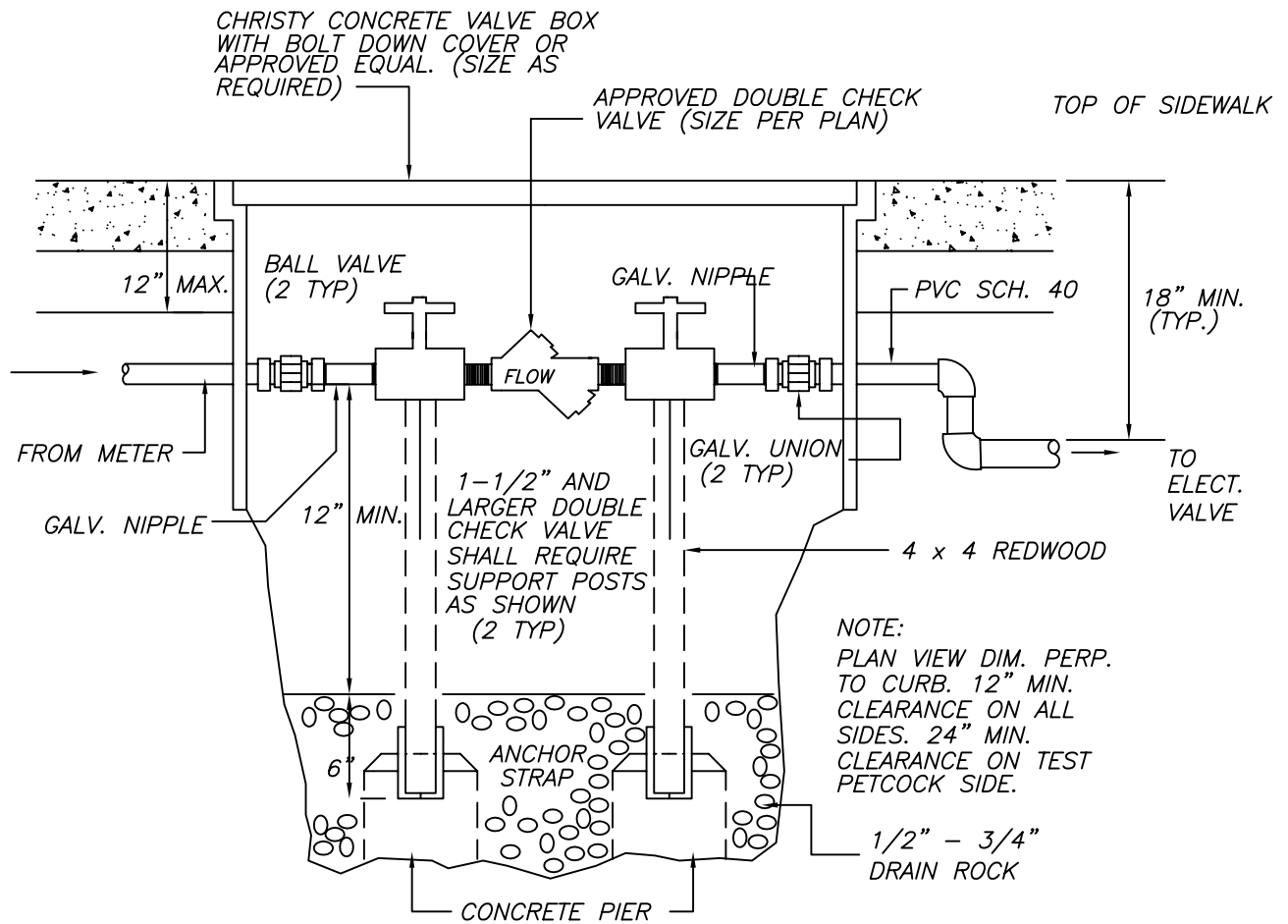

**SIDEWALK DOUBLE CHECK VALVE INSTALLATION**

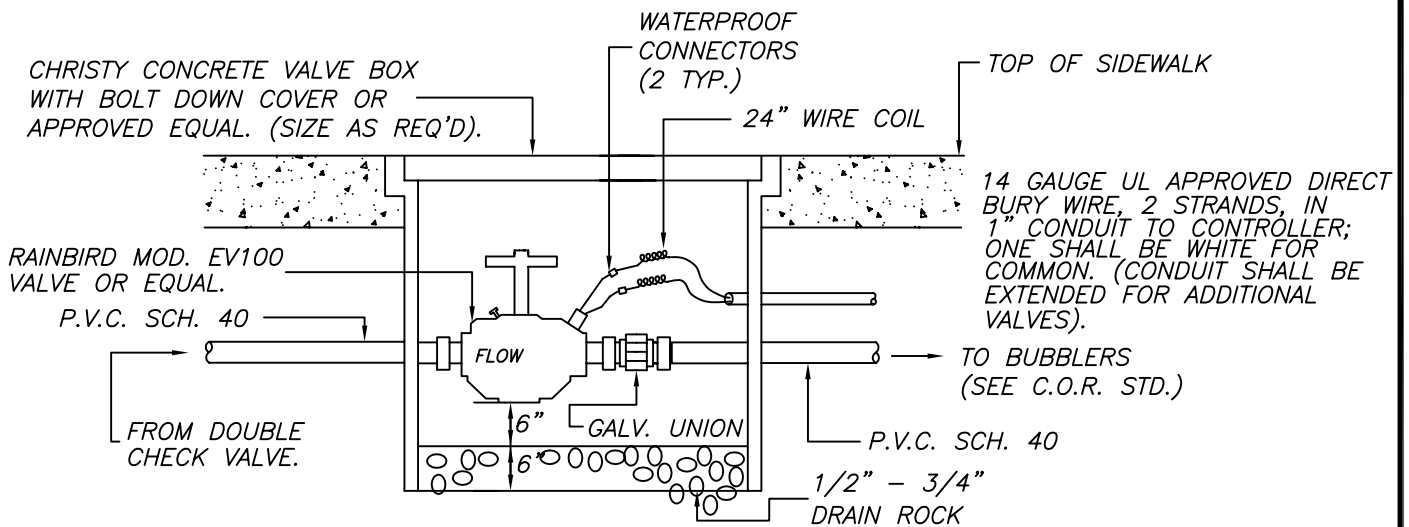

**ELECTRIC VALVE INSTALLATION**

NO.	REVISED	BY
DRAWN BY: MATT		
CHECKED BY: DJR		
SCALE: NONE		

**Typical Tree Well  
Irrigation System  
Requirements**

**CITY OF RIPON**

APPROVED
CITY ENGINEER RCE-28191
DATE: 2-2-99
STANDARD NO. <b>IRR-2</b>

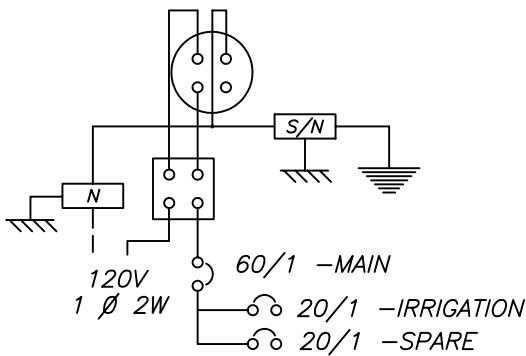

PANEL DIAGRAM

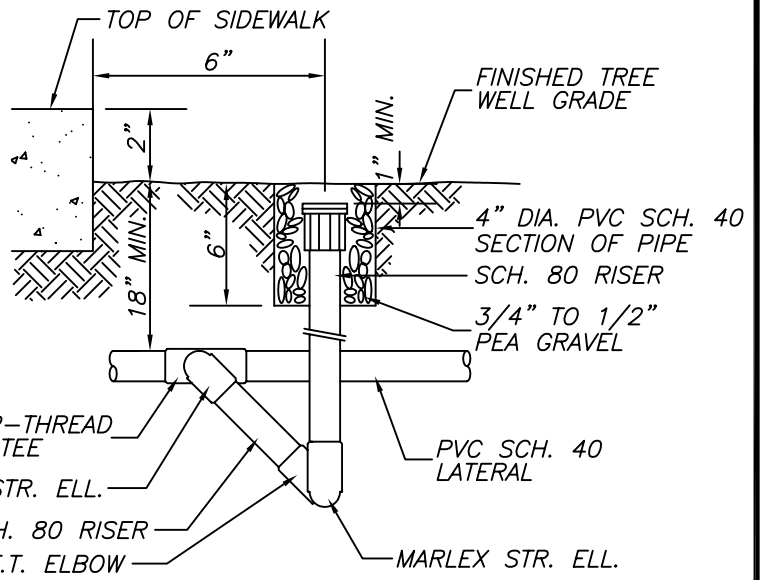

BUBBLER INSTALLATION

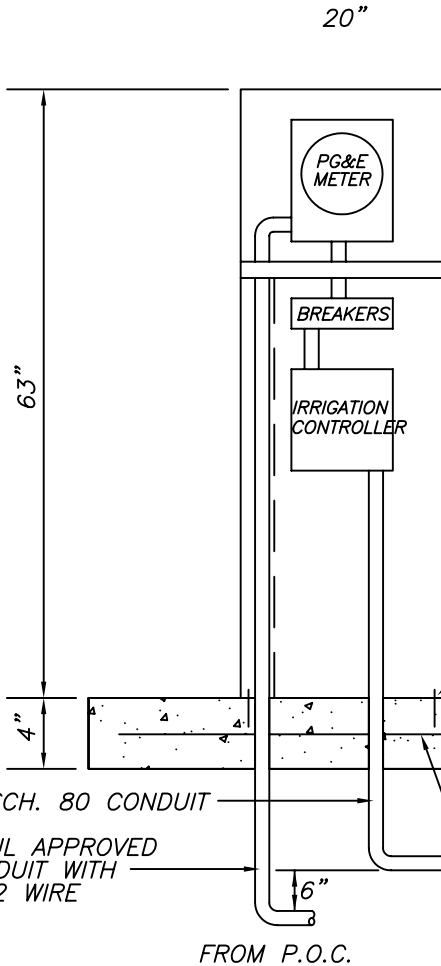

SECTION VIEW OF CABINET

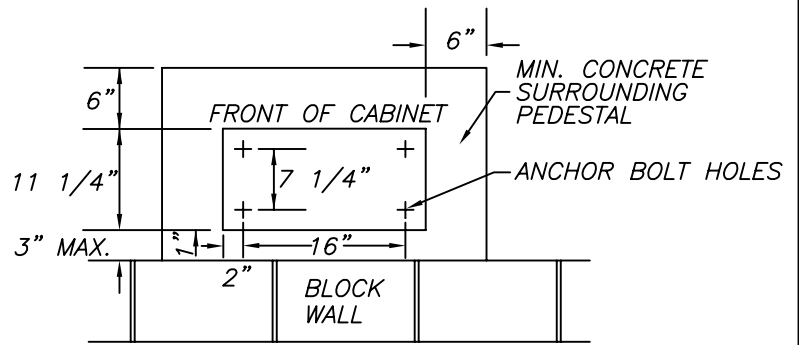

PLAN VIEW OF CABINET

NO.	REVISED	BY
DRAWN BY: TP		
CHECKED BY: DJR		
SCALE: NONE		

**Typical Tree Well  
Irrigation System  
Requirements**

**CITY OF RIPON**

APPROVED  
  
 CITY ENGINEER RCE-28191  
 DATE: 2-2-99

STANDARD NO. **IRR-3**

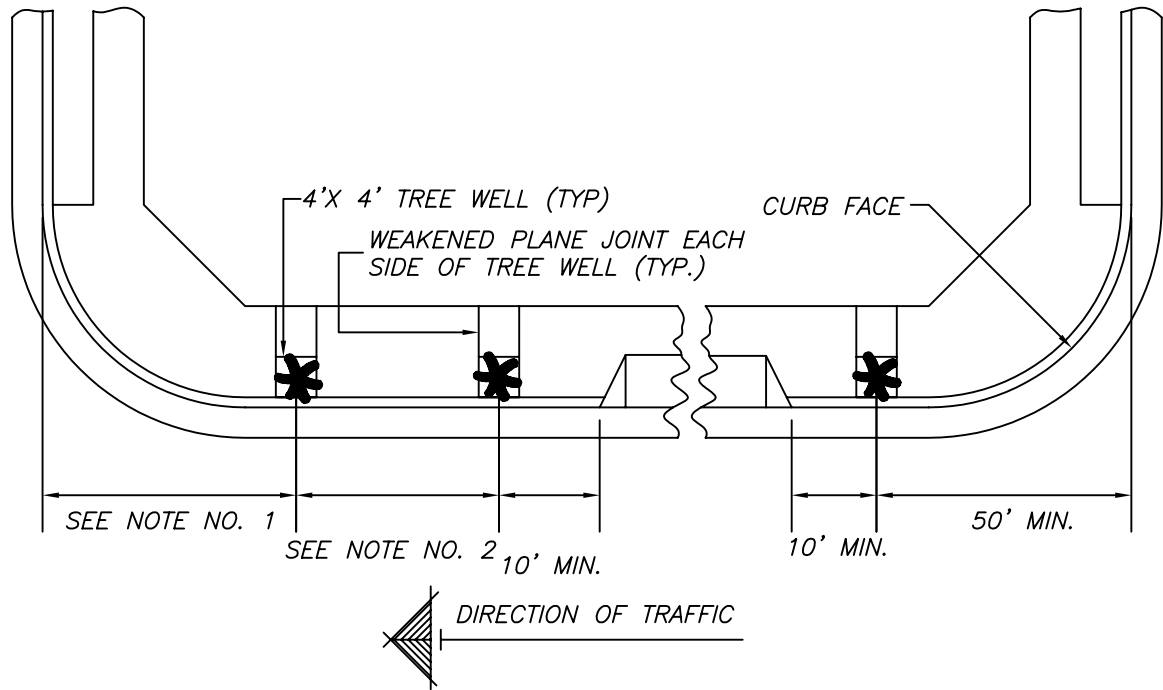

**NOTES:**

1. MINIMUM OF 100' BETWEEN THE FACE OF THE CROSS STREET CURB AND THE CENTER OF THE FIRST TREE WELL ON THE MAJOR STREETS. MINIMUM OF 40' ON ALL OTHER CITY STREETS. BOTH INSTALLATIONS SUBJECT TO APPROVAL BY THE CITY ENGINEER.
2. SPACING OF TREE WELLS SHALL BE 30' MIN.; 40' MAX. EQUALLY DIVIDED THROUGH THE BLOCK.
3. STANDARD SIZE OF TREE WELLS IS 4'X4'.
4. ALL NEW OR IMPROVED COMMERCIAL FRONTAGE SHALL HAVE TREE WELLS IF MONOLITHIC SIDEWALK IS INSTALLED. PLANS SHALL BE SUBMITTED TO THE CITY ENGINEER FOR APPROVAL.
5. SEE TYPICAL TREE WELL DETAIL.
6. AVOID UTILITY TRENCH BY A MINIMUM OF 6 FEET.
7. PROVIDE BUBBLER SPRINKLER HEAD TO EACH TREE WELL FROM ADJACENT LANDSCAPE AREA OR WATER SOURCE. FOR BACK-UP FRONTAGES, LOCATION OF METER AND VALVE TO BE APPROVED BY THE CITY ENGINEER.
8. A RP BACKFLOW PREVENTION DEVICE SHALL BE REQUIRED AT SERVICE CONNECTION.
9. ROOT BARRIERS REQUIRED FOR ALL TREE PLANTING. TYPE AND DESIGN TO BE APPROVED BY THE CITY ENGINEER.

NO.	REVISED	BY	<b>Typical Tree Well Installation</b>	APPROVED
				
				CITY ENGINEER RCE-28191
DRAWN BY: MCP				DATE: 2-2-99
CHECKED BY: DJR			<b>CITY OF RIPON</b>	STANDARD NO. <b>IRR-4</b>
SCALE: NONE				

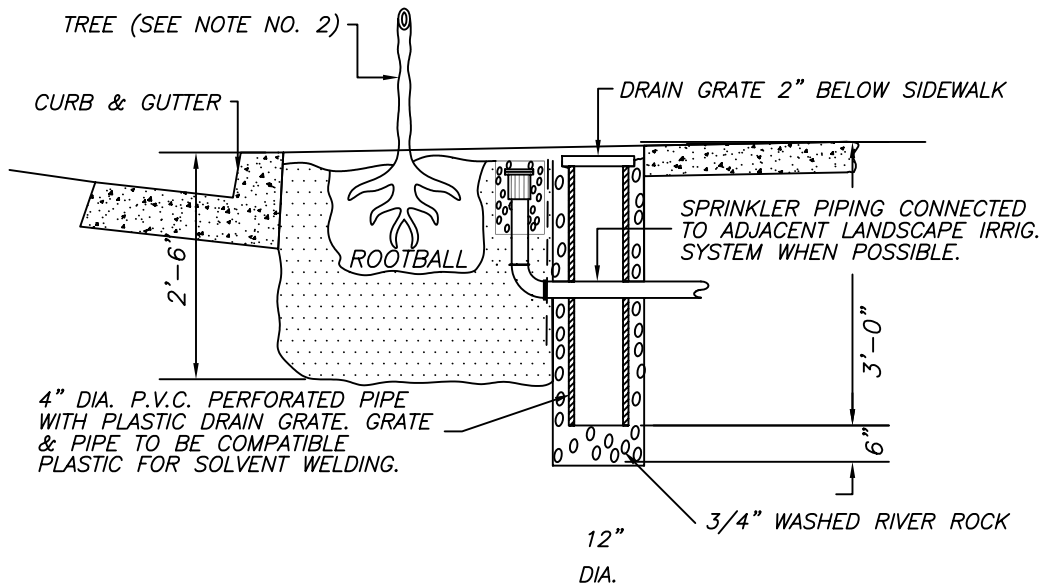
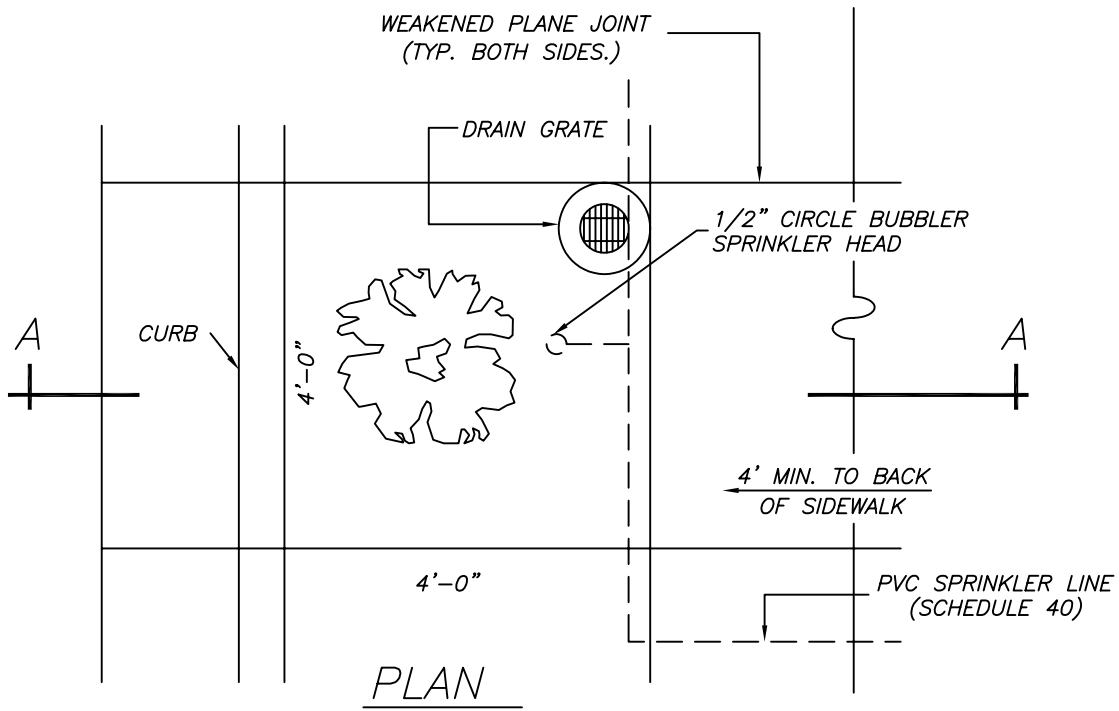

NOTES:

1. BACKFILL SHALL BE A FRIABLE LOAM, TYP. OF CULTIVATED TOPSOILS LOCALLY, CONTAINING AT LEAST 2% HUMUS. IT SHALL BE REASONABLY FREE OF SUBSOIL, STONES, CLOUDS, STICKS OR OTHER OBJECTIONABLE EXTRANEIOUS MATTER OR DEBRIS. IT SHALL NOT CONTAIN TOXIC MATERIALS.
2. TREE SPECIES SHALL BE SELECTED OR APPROVED BY THE CITY.
3. CONTROL VALVE, BACKFLOW PREVENTION ASSEMBLY, AND CONTROLLER PER APPROVED ENGINEERED PLANS.
4. ROOT BARRIERS REQUIRED FOR ALL TREE PLANTING. TYPE AND DESIGN TO BE APPROVED BY THE CITY ENGINEER.

NO.	REVISED	BY	<b>Typical Tree Well Detail</b>	APPROVED
				<i>[Signature]</i> CITY ENGINEER RCE-28191
				DATE: 2-2-99
DRAWN BY: MCP			<b>CITY OF RIPON</b>	STANDARD NO. <b>IRR-5</b>
CHECKED BY: DJR				
SCALE: NONE				



THIS PAGE  
INTENTIONALLY LEFT BLANK

NO.	REVISED	BY	APPROVED
			
			CITY ENGINEER RCE-28191
DRAWN BY:			DATE: 2-2-99
CHECKED BY:			STANDARD NO. <b>IRR-6</b>
SCALE: NONE			
<b>CITY OF RIPON</b>			

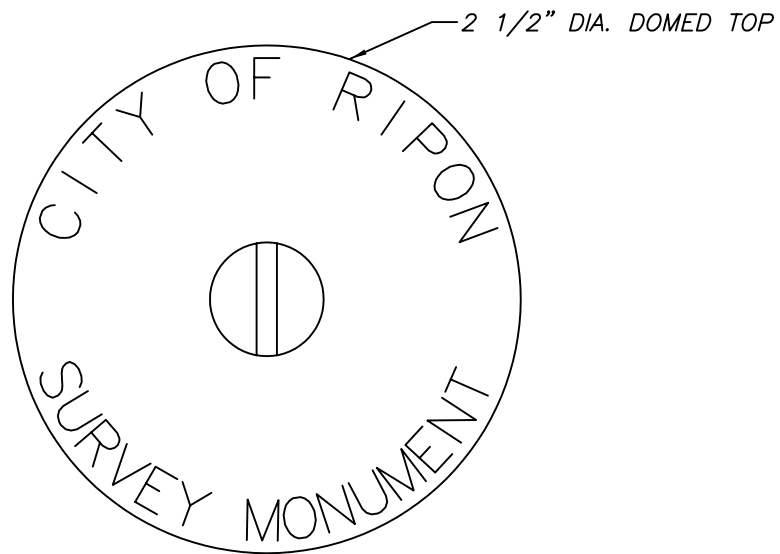

PLAN

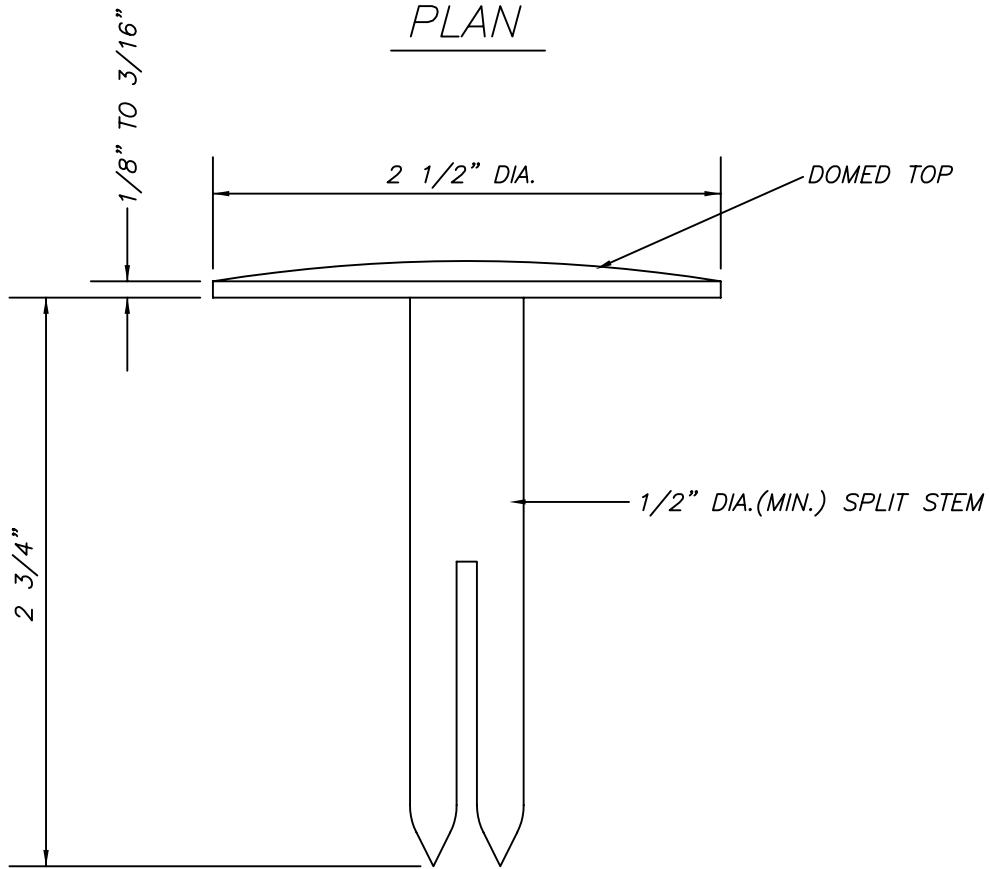

ELEVATION

NO.	REVISED	BY	<b>Survey Monument Marker</b>	APPROVED 
				CITY ENGINEER RCE-28191
DRAWN BY: TP				DATE: 2-2-99
CHECKED BY: DJR			<b>CITY OF RIPON</b>	STANDARD NO. <b>M-1</b>
SCALE: NONE				

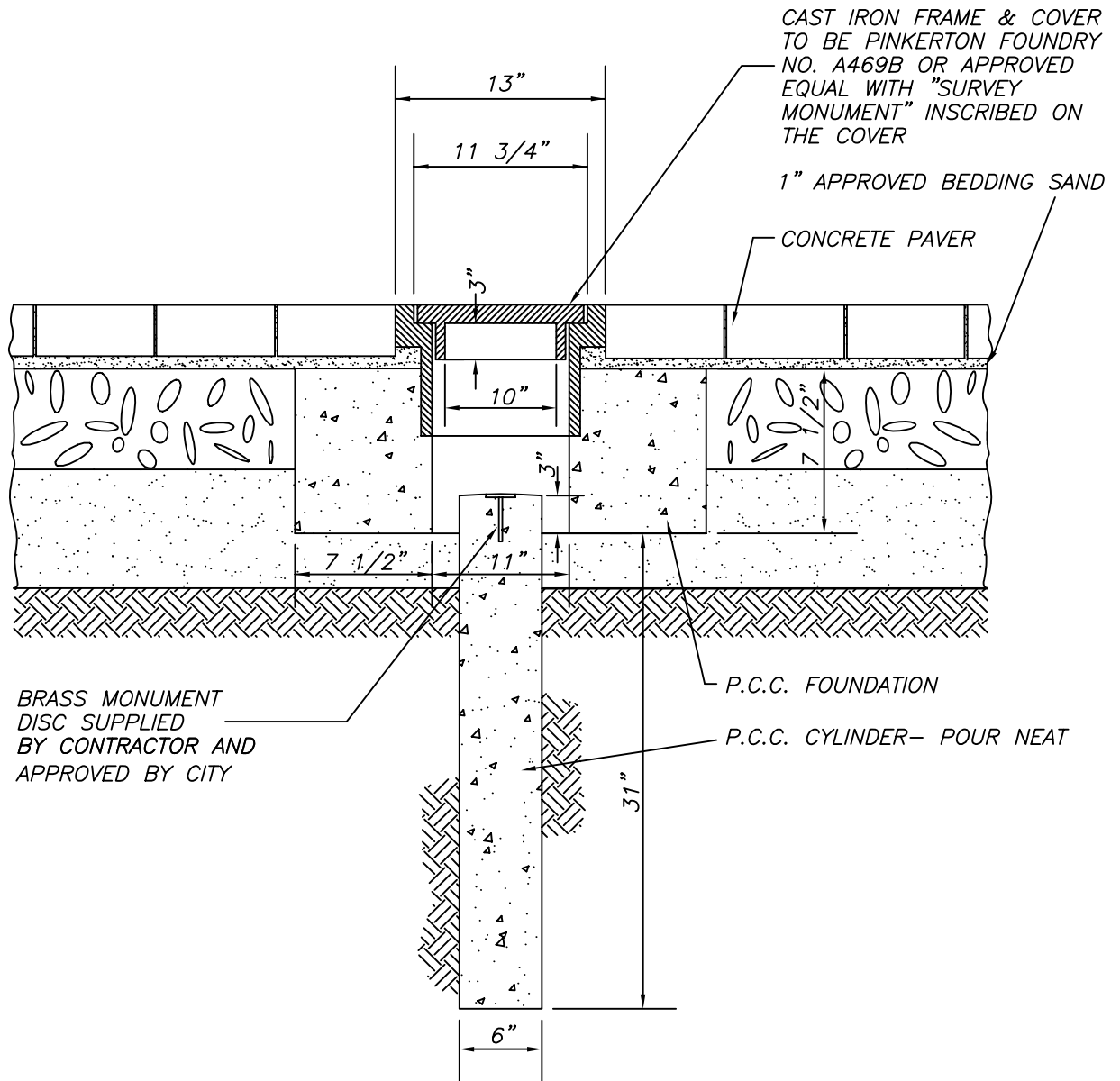

**NOTES:**

1. MONUMENT FRAME AND COVER SHALL CONFORM TO THE CURRENT A.S.T.M. SPECIFICATIONS. COVERS SHALL BE GROUND OR OTHERWISE FINISHED SO THAT THEY WILL FIT THE FRAME WITHOUT ROCKING.
2. EXTENSION GRADE RINGS MUST BE AVAILABLE FOR FRAME AND COVER USED.
3. STAMP IDENTIFICATION MARK ON BRASS DISC OF LICENSED INDIVIDUAL SETTING MONUMENT.
4. MONUMENTS TO BE INSTALLED AT THE INTERSECTION OF ARTERIAL STREETS AS ESTABLISHED IN THE CITY OF RIPON GENERAL PLAN.

NO.	REVISED	BY	<b>Special Monument Installation</b>	APPROVED
				
				CITY ENGINEER RCE-28191
DRAWN BY: TP			<b>CITY OF RIPON</b>	DATE: 2-2-99
CHECKED BY: DJR				STANDARD NO. <b>M-2</b>
SCALE: NONE				

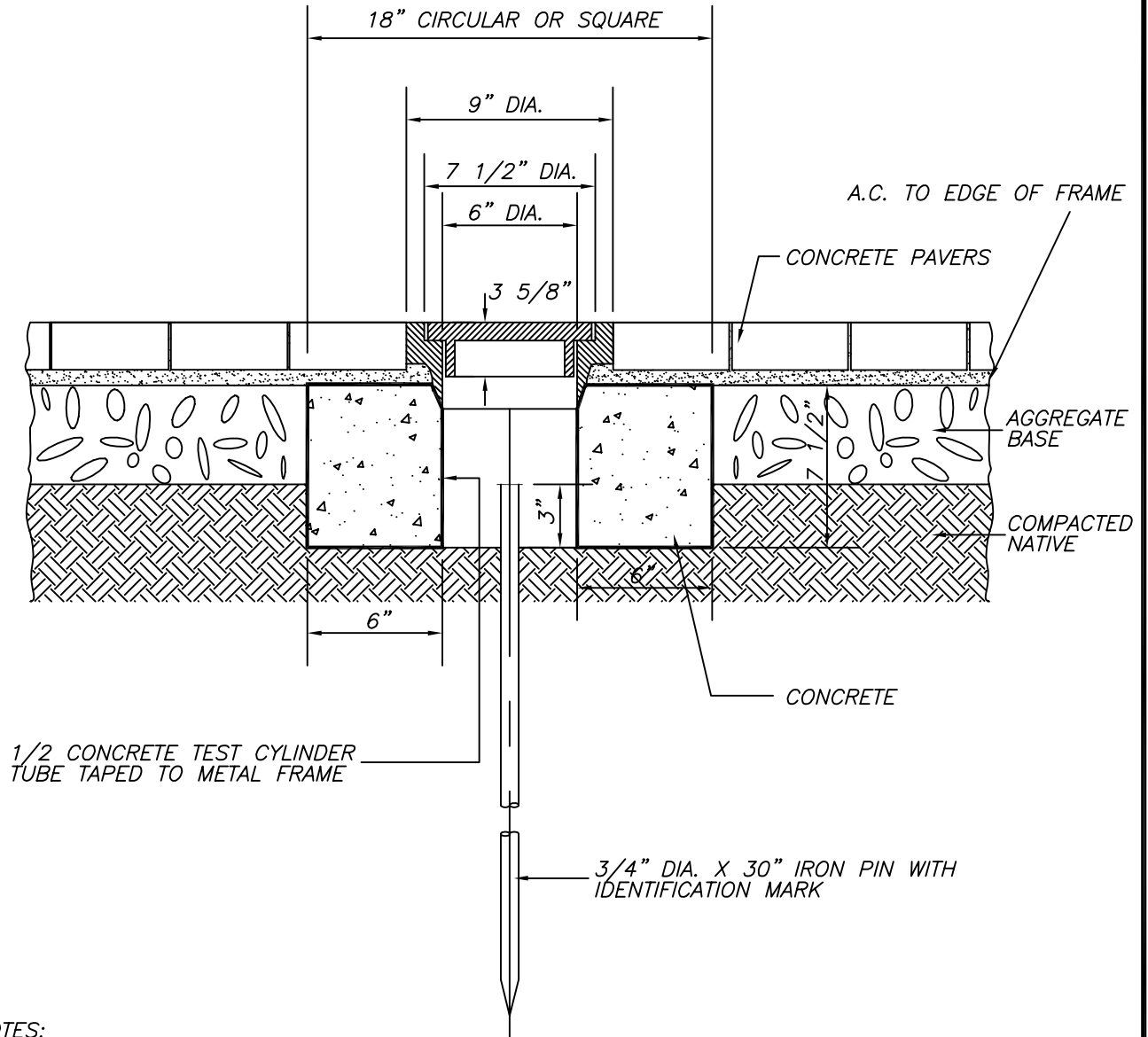

NOTES:

1. SET MONUMENT, FRAME AND COVER AFTER PAVEMENT IS IN PLACE.
2. MONUMENT FRAMES AND COVERS SHALL BE TOUGH GREY IRON CASTING CONFORMING TO THE LATEST A.S.T.M. REQUIREMENTS. EACH COVER SHALL BE GROUND OR OTHERWISE FINISHED SO THAT IT WILL FIT IT'S FRAME WITHOUT ROCKING.
3. FRAME AND COVER TO BE PINKERTON FOUNDRY NO. A-581M, AMERICAN BRASS AND IRON FOUNDRY, OR EQUAL. CAST IRON COVER TO BE MARKED MONUMENT.
4. MONUMENTS TO BE SET AT ALL INTERSECTIONS, ENDS OF CUL-DE-SACS, AT B.C. & E.C. OF CURVES AND AT ENDS OF SUBDIVISION. ON LONG TANGENTS, THE MAXIMUM DISTANCE BETWEEN MONUMENTS SHALL NOT EXCEED 800'. MONUMENTS SHALL BE EQUALLY SPACED.

NO.	REVISED	BY	APPROVED	
			<i>David R...</i> CITY ENGINEER RCE-28191	
DRAWN BY: TP			DATE: 2-2-99	
CHECKED BY: DJR			<b>CITY OF RIPON</b>	
SCALE: NONE				

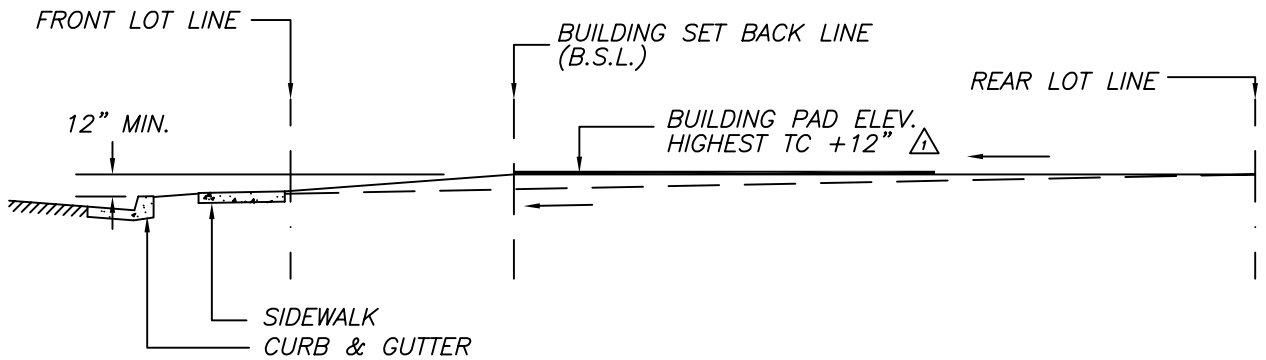
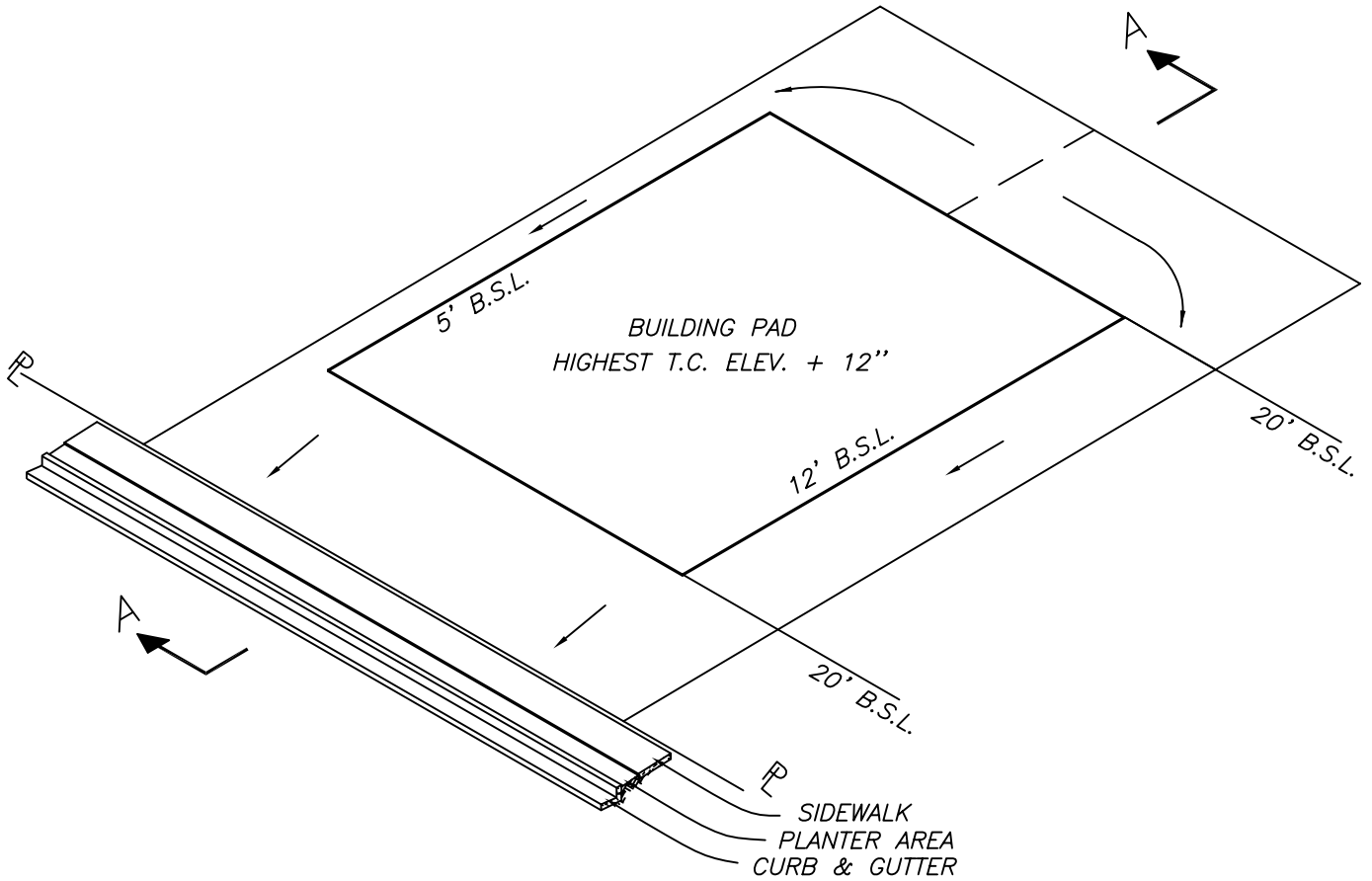

$\Delta$  LOT GRADING

1. BUILDING PAD ELEVATION TO BE DETERMINED BY LOT DRAINAGE CRITERIA AS SHOWN ABOVE FOR R-1 ZONING ONLY

SECTION A-A

2. GRADE TOWARD STREET AWAY FROM HOUSE

NO.	REVISED	BY	<b>Typical Interior Lot Grading Detail</b>	APPROVED
$\Delta$	1-2003	MJM		 CITY ENGINEER RCE-28191
DRAWN BY: M.C.P				DATE: 2-2-99
CHECKED BY: DJR			<b>CITY OF RIPON</b>	STANDARD NO. <b>M-4</b>
SCALE: NONE				

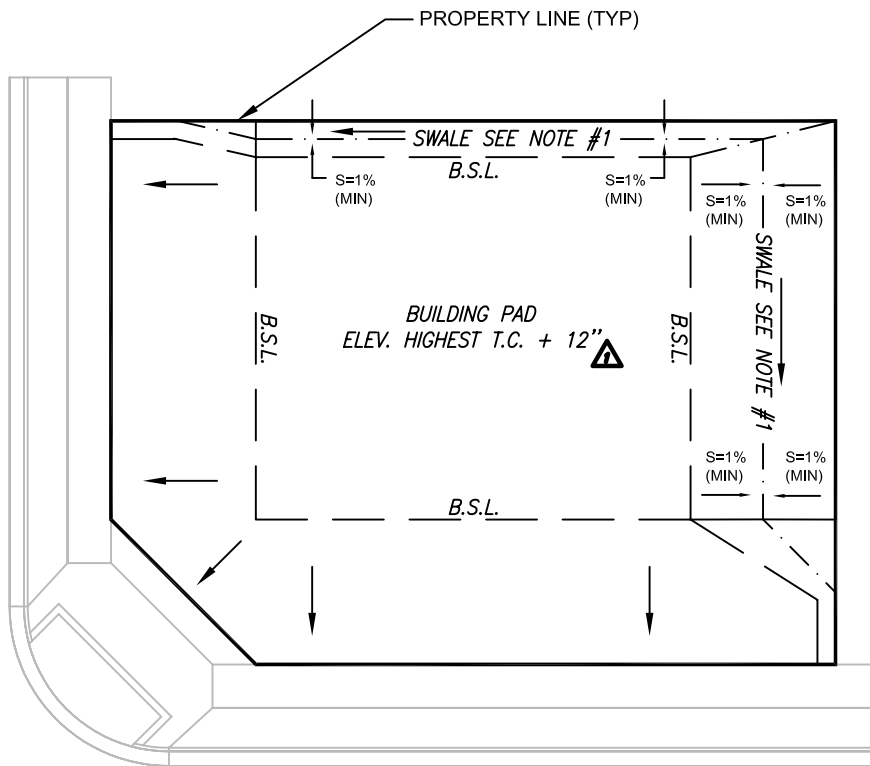

1. AT FINAL INSPECTION FOR A HOUSE, A DRAINAGE SWAIL WITH 1'-0" OR 1% MINIMUM FALL FROM BACK OF LOT TO FRONT OF LOT, WHICHEVER IS LESS, SHALL BE CONSTRUCTED AROUND THE HOUSE TO THE BACK OF LOT, FOR R-1 ZONING ONLY.

$\triangle = \triangle 1-10-03$

NO.	REVISED	BY	<b>Typical Corner Lot Grading Detail</b>	APPROVED
$\triangle$	1-2003	MJM		 CITY ENGINEER RCE-28191
				DATE: 2-2-99
DRAWN BY: MCP			<b>CITY OF RIPON</b>	STANDARD NO. <b>M-4a</b>
CHECKED BY: DJR				
SCALE: NONE				

***THIS PAGE  
INTENTIONALLY LEFT BLANK***

<i>NO.</i>	<i>REVISED</i>	<i>BY</i>		<i>APPROVED</i>	
					<hr/>
					<i>CITY ENGINEER RCE-28191</i>
<i>DRAWN BY:</i>				<i>DATE:</i>	
<i>CHECKED BY:</i>			<b><i>CITY OF RIPON</i></b>	<i>STANDARD NO. M-5</i>	
<i>SCALE: NONE</i>					

PROPOSED GRADE OF MANHOLE FRAME  
VALVE BOX FRAME, OR MONUMENT  
COVER FRAME.

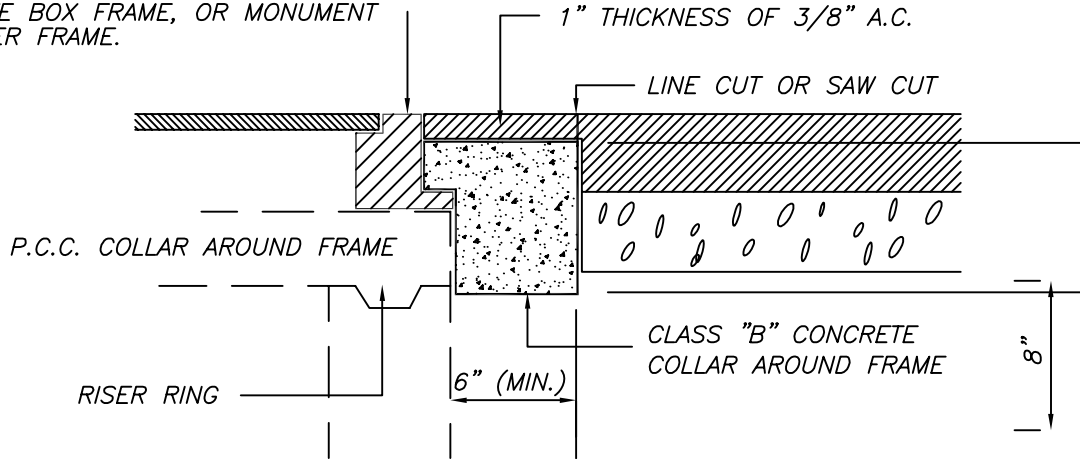

NOTES:  
ELEVATION OF FRAME SHALL MATCH FINISH  
GRADE OF ADJACENT PAVEMENT + 1/8".

ADJUSTING EXISTING FRAMES

PROPOSED GRADE OF MANHOLE FRAME  
VALVE BOX FRAME, OR MONUMENT

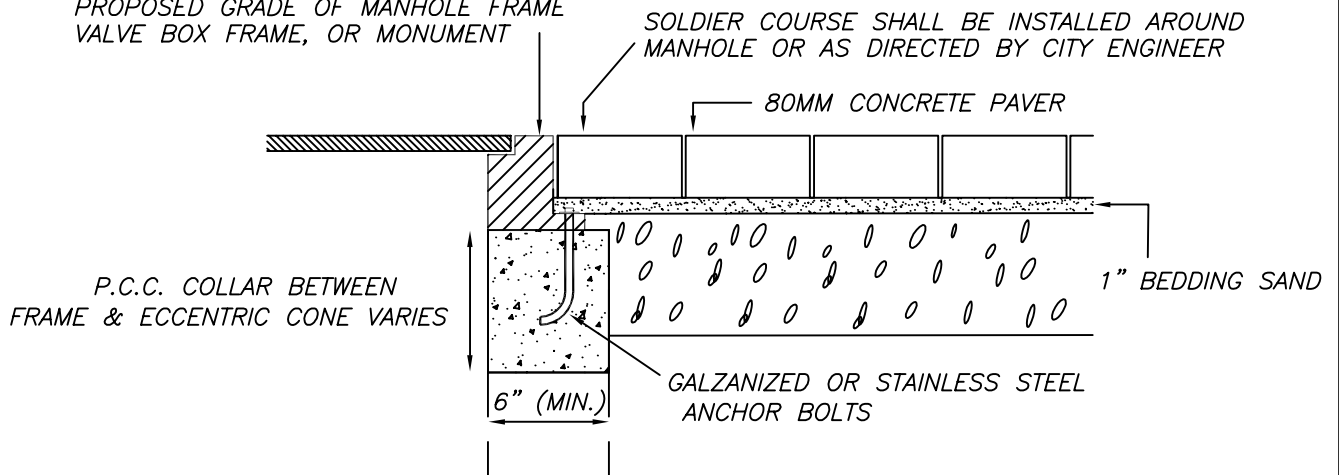

NOTES:  
ELEVATION OF FRAME SHALL MATCH FINISH  
GRADE OF ADJACENT PAVEMENT ± 1/8".  
MINIMUM OF 3 ANCHOR BOLTS MUST BE USED.

ADJUSTING NEW FRAMES

NO.	REVISED	BY
DRAWN BY: MCP		
CHECKED BY: DJR		
SCALE: NONE		

**Adjusting Street  
Facilities to Grade**

**CITY OF RIPON**

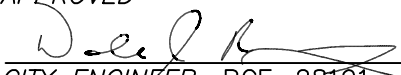
APPROVED  CITY ENGINEER RCE-28191
DATE: 2-2-99
STANDARD NO. <b>M-6</b>



# NOTES

1. MOUNTING HARDWARE TO BE "HAWKINS HEAVY DUTY" SLOTTED BACK V14(HD)SL2C2P, OR APPROVED EQUAL.
2. SIGN PLATE TO BE .125", 5052-H38 ALUMINUM, WITH REFLECTIVE PRESSURE SENSITIVE LEGEND SHEETING.
3. LEGEND SHEETING SHALL CONSIST OF A WHITE OR SILVER BACKGROUND WITH BLACK COPY, FULLY REFLECTORIZED, GOTHIC STYLE LETTERS.
4. STREET NAME SIGNS TO BE INSTALLED IN SUBDIVISIONS BY THE CONTRACTOR WITH COPY, AND AT LOCATIONS AS DIRECTED BY THE CITY ENGINEER.

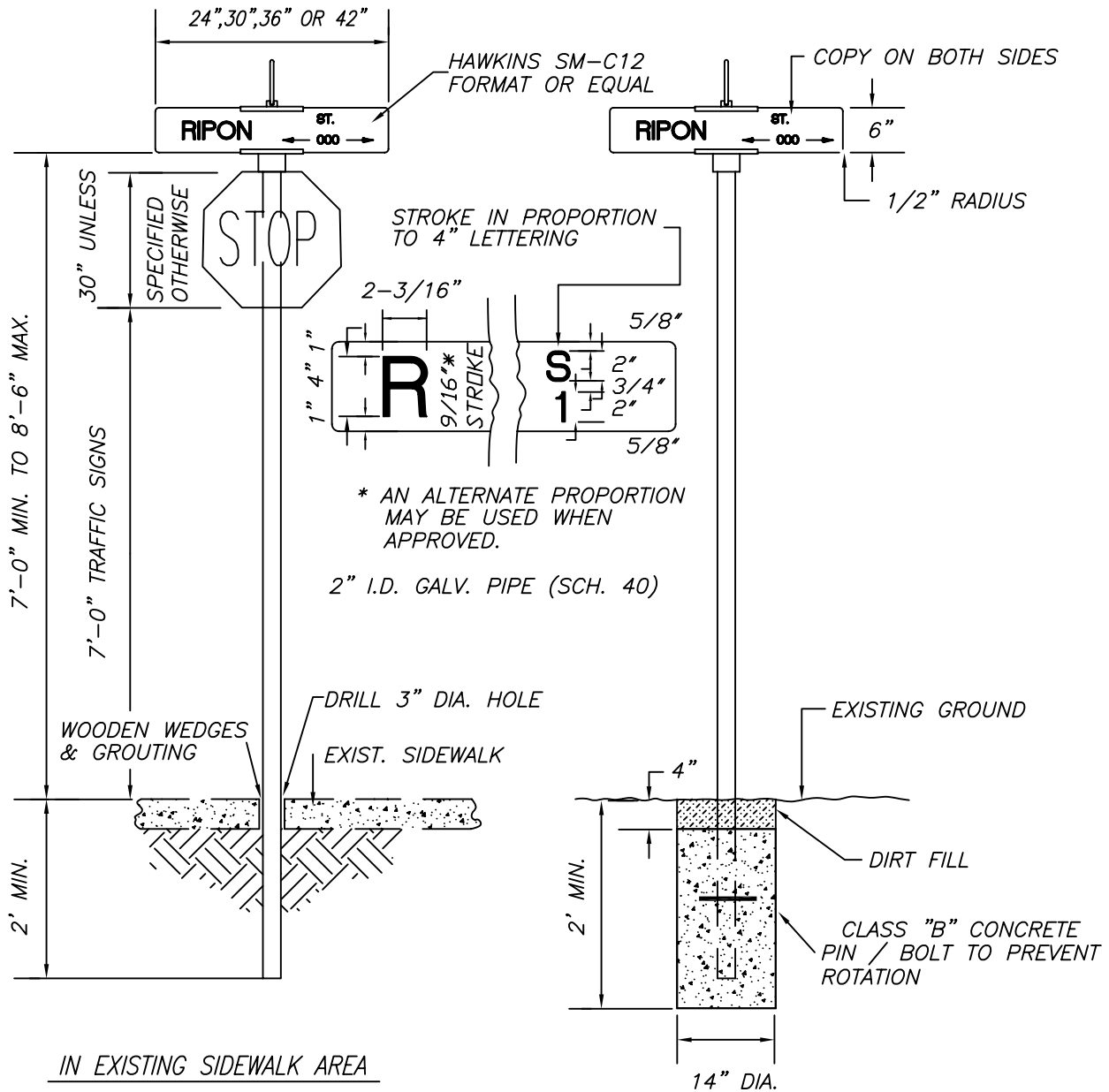

SEE C.O.R. STANDARDS FOR LOCATION

NO.	REVISED	BY	<b>Street Name Sign</b>	APPROVED
				<i>[Signature]</i>
				CITY ENGINEER RCE-28191
DRAWN BY: MCP				DATE: 2-2-99
CHECKED BY: DJR			<b>CITY OF RIPON</b>	STANDARD NO. <b>M-7</b>
SCALE: NONE				

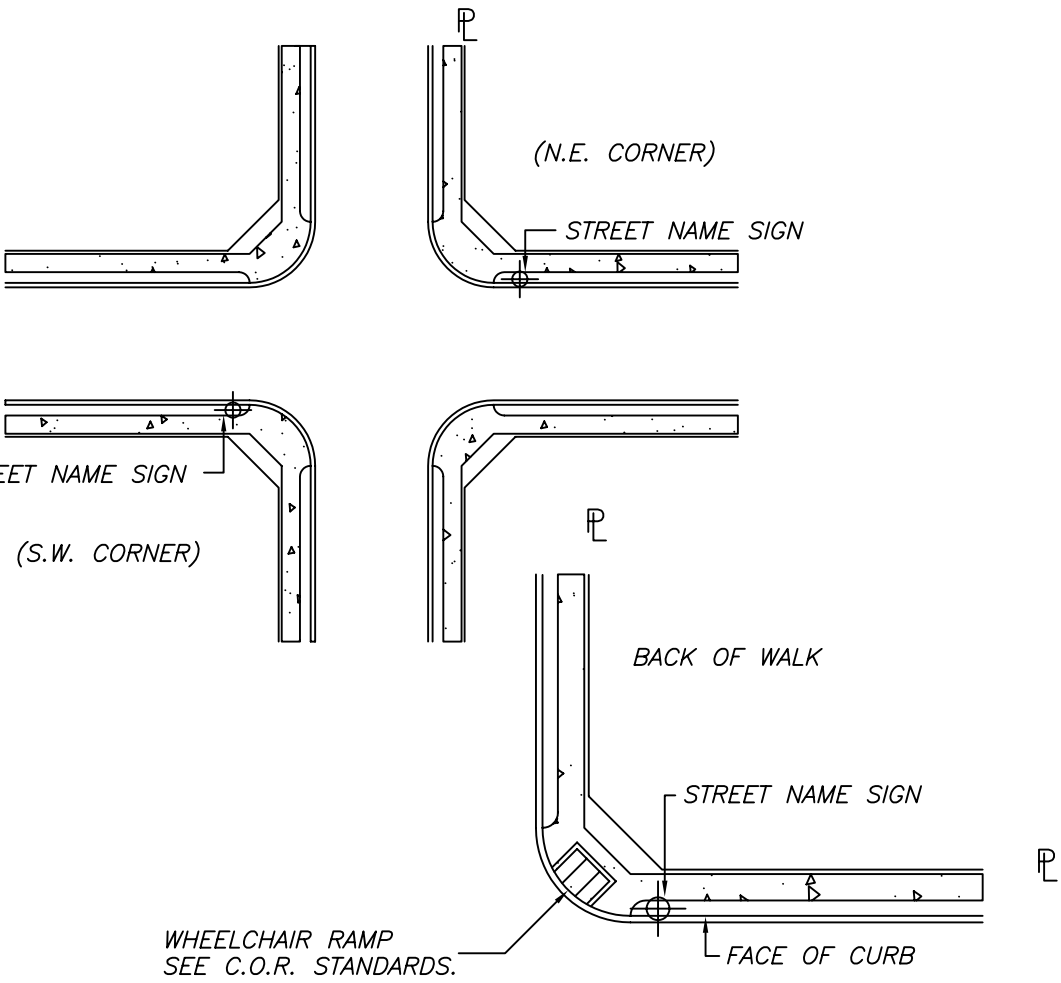

LOCATION OF STREET NAME SIGNS IN  
NEW SUBDIVISIONS AND NEW STREETS

NOTES:

1. DRILL 3" DIA. HOLE IN CONCRETE IF SIGN IS INSTALLED AFTER SIDEWALK HAS BEEN CONSTRUCTED.
2. SIGN LOCATION SHALL BE AS FOLLOWS: ON RESIDENTIAL STREETS, N.E. CORNER ONLY; ON MAJOR ARTERIALS N.E. & S.W. CORNERS; ON INTERSECTIONS OF MAJOR ARTERIALS ALL 4 CORNERS.
3. NO PARKING, AND OTHER WARNING SIGNS TO BE PLACED BEHIND SIDEWALK; LOCATION TO BE DETERMINED BY THE CITY OF RIPON.

NO.	REVISED	BY	<b>Street Name Sign Location</b>	APPROVED	 CITY ENGINEER RCE-28191
				DATE: 2-2-99	
DRAWN BY: MCP				STANDARD NO. <b>M-8</b>	
CHECKED BY: DJR			<b>CITY OF RIPON</b>		
SCALE: NONE					

PER CALTRANS "MANUAL OF TRAFFIC CONTROLS"

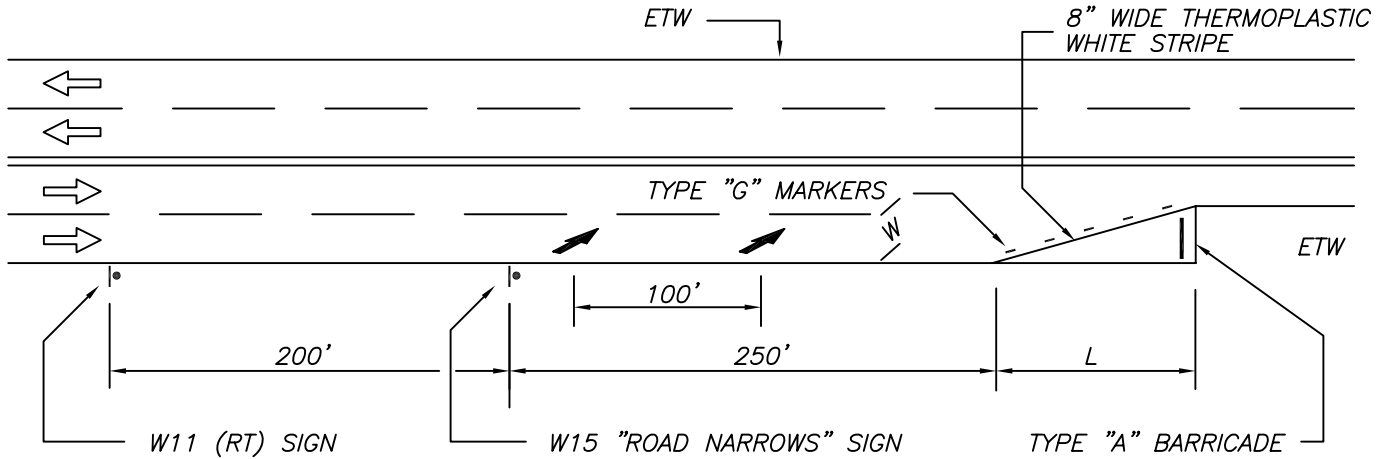

LEGEND

- L = LANE REDUCTION LENGTH (FT.)
- W = OFFSET DISTANCE (FT.)
- S = OFF PEAK 85 PERCENTILE SPEED (IN 5 MPH)
- DIRECTION OF TRAVEL
- ↘ LANE DROP ARROW
- ETW= EDGE OF TRAVELED WAY

NOTES:

1. THE LENGTH OF TRANSITION (L) SHOULD BE COMPUTED BY FORMULA  $L=WS$  FOR ALL HIGHWAYS WITH SPEEDS OF 45 MPH OR MORE.
2. ON URBAN, RESIDENTIAL, AND OTHER STREETS WHERE SPEEDS ARE 40 MPH OR LESS, THE FORMULA  $L=WS^2/60$  MAY BE USED.
3. RAISED PAVEMENT MARKERS, TYPE G (CLEAR) IN SECTION 85-1.02 OF CALTRANS STANDARD SPECIFICATIONS, ARE TO BE USED AT A TWO INCH OFFSET TO THE THERMOPLASTIC STRIPE (ON THE TRAFFIC SIDE). MARKERS SHALL BE SET AT 24' ON CENTER.
4. A SECOND SET OF LANE DROP ARROWS MAY BE PLACED IN ADVANCE OF THE W11 SIGN. THE LANE DROP ARROWS ARE OPTIONAL ON HIGHWAYS WHERE SPEEDS ARE 40 MPH OR LESS.
5. A 100' MINIMUM DISTANCE MAY BE USED FOR LANE DROP ARROWS ON AN URBAN, RESIDENTIAL, OR OTHER STREET WHERE SPEEDS ARE 40 MPH OR LESS.

NO.	REVISED	BY	<b>Lane Reduction Transition</b>	APPROVED
				CITY ENGINEER RCE-28191
DRAWN BY: TP				DATE: 2-2-99
CHECKED BY: DJR			<b>CITY OF RIPON</b>	STANDARD NO. <b>M-9</b>
SCALE: NONE				

**NOTE:**

REFLECTORS SYMMETRICALLY  
PLACED 12' ± C/C

REFLECTOR SIGN - CALIFORNIA  
HIGHWAY CODE N-1, OR N-4  
SIZE 18"X18" YELLOW WITH NINE  
3" DIA. YELLOW REFLECTORS

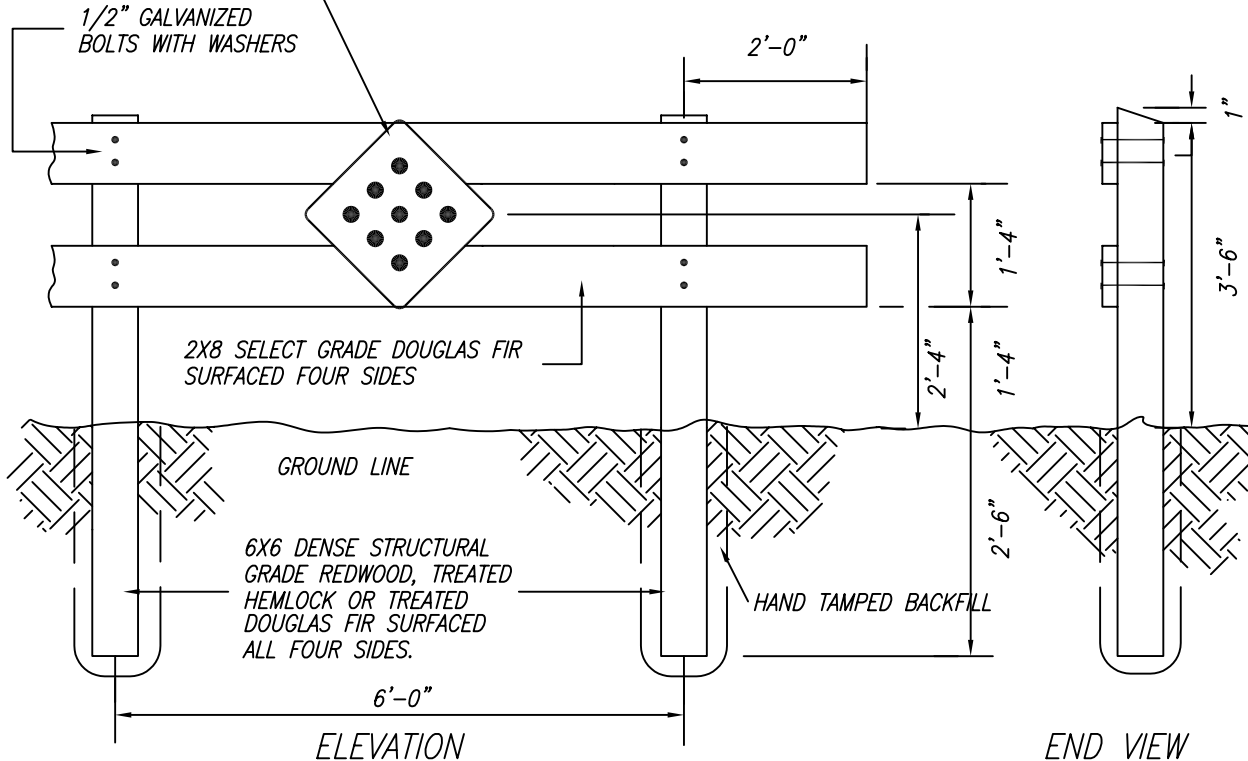

**ELEVATION**

**END VIEW**

**TYPE "A"**

**NOTES:**

1. TYPE "A" BARRICADE TO BE AS WIDE AS STREET RIGHT-OF-WAY.
2. BARRICADES TO BE PAINTED YELLOW USING 2 COATS "EXTERIOR ALKYD RESIN HI- GLOSS ENAMEL" OVER A COMPATIBLE PRIMER - APPLY REFLECTIVE BEADS.
3. SEE PLANS FOR TYPE OF REFLECTOR SIGNS AND BARRICADE.

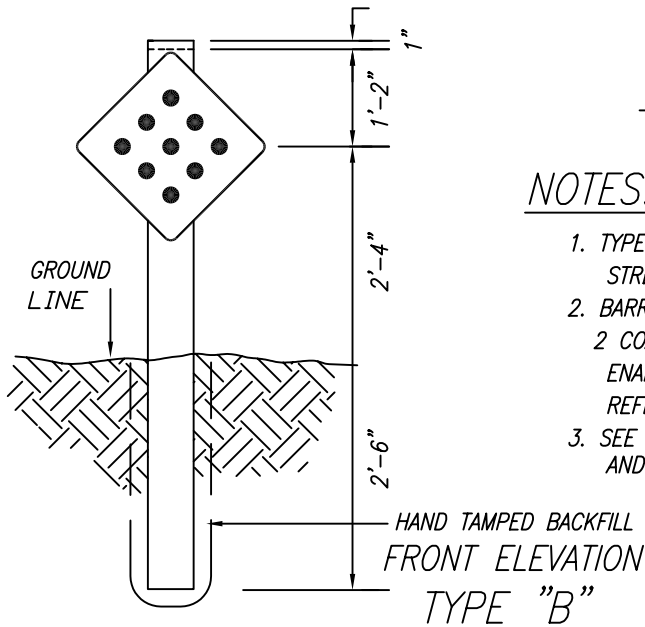

**TYPE "B"**

NO.	REVISED	BY	<b>Barricades for Terminating Streets</b>	APPROVED
				 CITY ENGINEER RCE-28191
				DATE: 2-2-99
DRAWN BY: MCP			<b>CITY OF RIPON</b>	STANDARD NO. <b>M-10</b>
CHECKED BY: DJR				
SCALE: NONE				

1. *The minimum height of the sound and safety / sound barrier wall shall be eight (8) feet measured from the roadway elevation at the centerline of the nearest travel lane, or from the centerline of the nearest future travel lane. This standard shall achieve an acceptable outdoor residential Ldn (day-night weighted average noise level) value of 65 dB (decibels) or less, and an indoor residential Ldn value of 45 dB or less, in any habitable room with windows closed.*
2. *The developer shall submit to the Planning Department an acoustics engineer's report indicating sound attenuation values and sound barrier design, for evaluation during the final map and review process. If required by the City, a safety / sound barrier wall design shall be substituted for the sound barrier design. The construction of the barrier wall shall be incorporated with construction of the subdivision improvements. If approved by the City, adjacent projects may utilize the same report and design.*
3. *The sound barrier and the top portion of the safety / sound barrier wall shall be constructed of solid nonporous materials with a mass value of at least four (4) pounds per square foot. All joints shall be sealed to prevent the passage of sound waves.*
4. *The sound barrier of the top portion of the safety / sound barrier wall shall be constructed of either concrete panel-lock, brick, concrete block, or prefab tilt-up.*
5. *Emergency access panels shall be installed in accordance with California Department of Transportation requirements.*
6. *The overall height of the barrier wall may be achieved in combination with an earth berm (subject to approval by the City).*
7. *Residential lots adjacent to the noise generating source shall have a rear yard setback of 30 feet.*
8. *Design details, signed and stamped by a registered civil engineer and a manufacturer's description of the proposed wall, shall be made part of the subdivision improvement plans and submitted prior to approval of the final map. Design of the safety / sound barrier wall shall be approved by the engineer.*

NO.	REVISED	BY	<b>Sound Wall Design Criteria</b>	APPROVED	 CITY ENGINEER RCE-28191
				DATE: 2-2-99	
DRAWN BY: Matt				<b>CITY OF RIPON</b>	STANDARD NO. <b>M-11</b>
CHECKED BY: DJR					
SCALE: NONE					

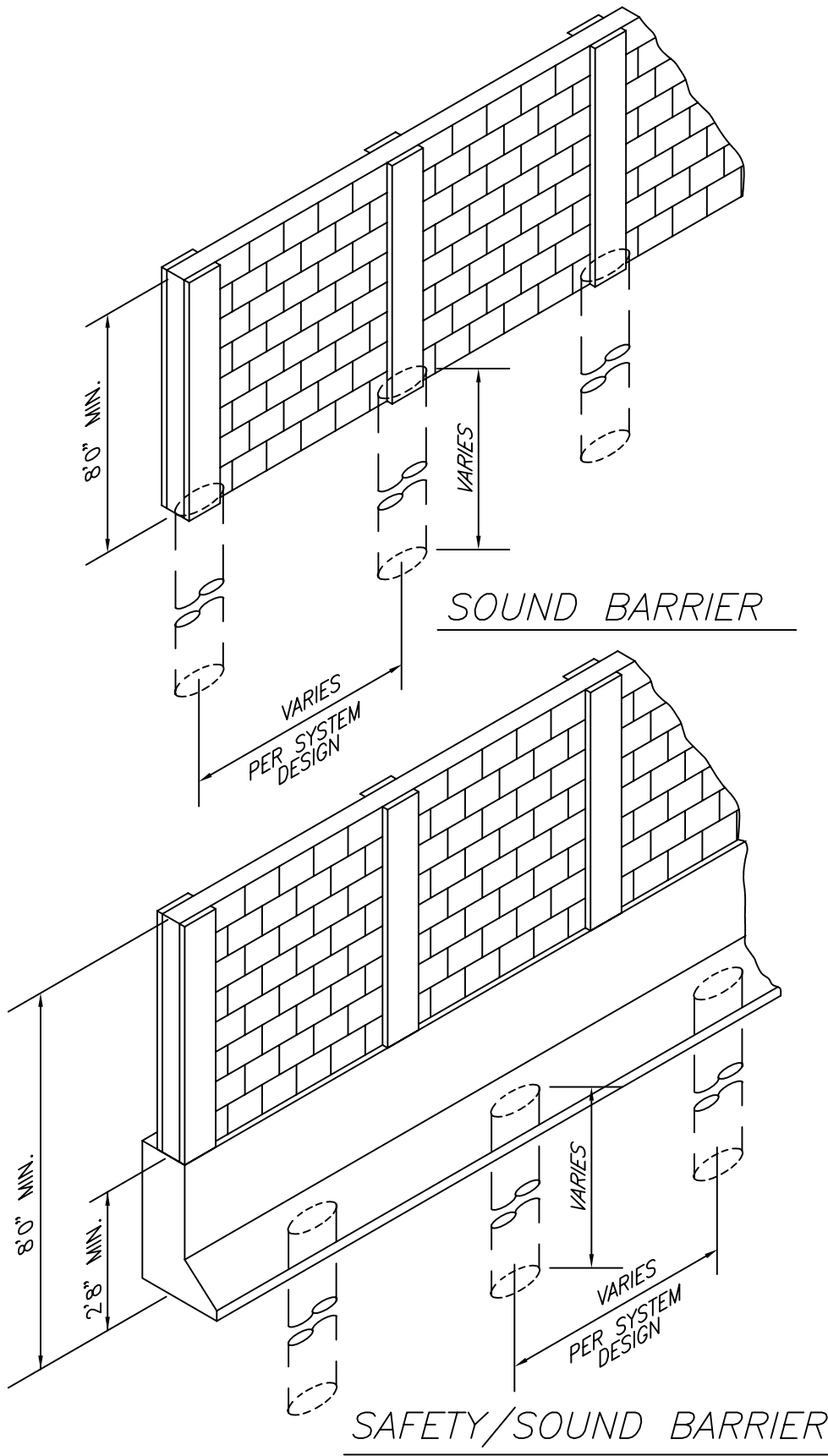

NO.	REVISED	BY	<b>Sound Walls</b>	APPROVED	
				<i>[Signature]</i>	CITY ENGINEER RCE-28191
				DATE: 2-2-99	
DRAWN BY: TP			<b>CITY OF RIPON</b>	STANDARD NO. <b>M-12</b>	
CHECKED BY: DJR					
SCALE: NONE					

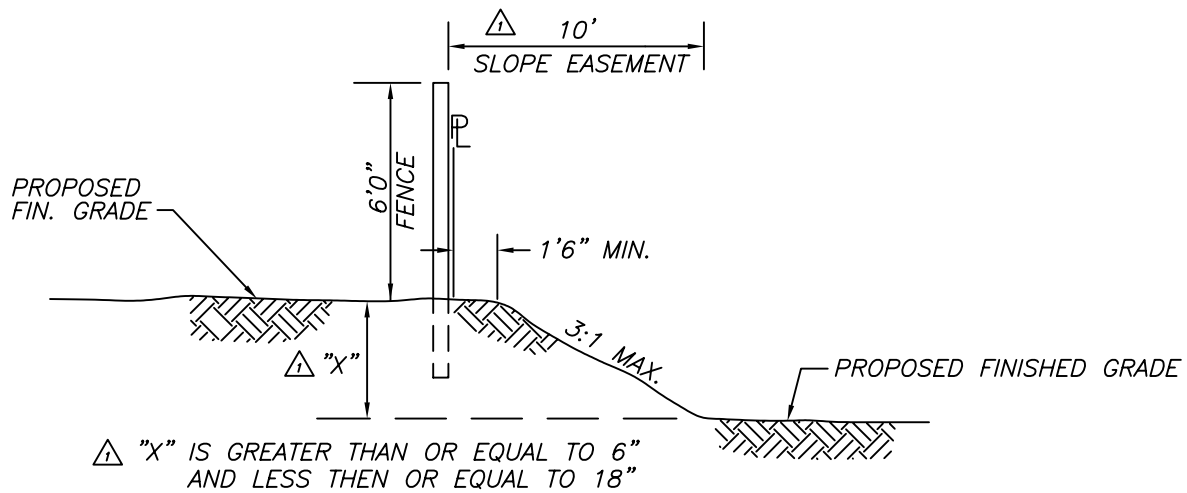

TO BE USED FOR LOT DIFFERENCE LESS THAN 18"

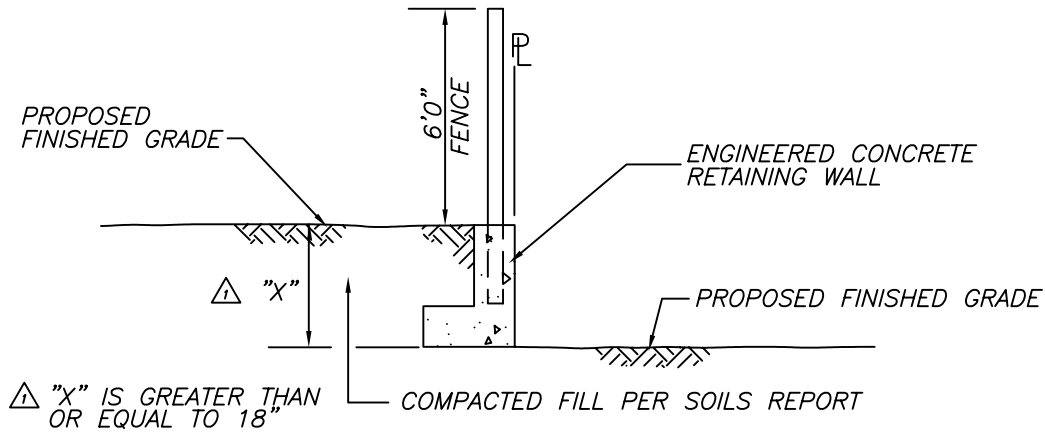

TO BE USED FOR LOT DIFFERENCE OF 18" OR GREATER

NOTES:

1. DETAILS AND CALCULATIONS FOR THE CONCRETE RETAINING WALL SHALL BE SUBMITTED TO THE CITY OF RIPON ENGINEERING DEPARTMENT FOR APPROVAL.

NO.	REVISED	BY	<b>Property Line Retaining Wall</b>	APPROVED
△	1-2003	MJM		 CITY ENGINEER RCE-28191
				DATE: 2-2-99
DRAWN BY: TP			<b>CITY OF RIPON</b>	STANDARD NO. <b>M-13</b>
CHECKED BY: DJR				
SCALE: NONE				

TYPICAL MEMBER DIMENSIONS										(SEE NOTES)	
FENCE HEIGHT	LINE POSTS			END, LATCH & CORNER POSTS			BRACES				
	ROUND (I.D.)	H	ROLL FORMED	ROUND (I.D.)	ROLL FORMED		ROUND (I.D.)	H	ROLL FORMED		
6' AND LESS	1-1/2"	1-7/8" X 1-5/8"	1-7/8" X 1-5/8"	2"	3-1/2" X 3-1/2"	2" X 1-3/4"	1-1/4"	1-1/2" X 1-5/16"	1-5/8" X 1-1/4"	1-3/4" X 1-1/4"	1-3/4" X 1-1/4"
OVER 6' AND OR W/ FABRIC	2"	2-1/4" X 2"	2" X 1-3/4"	2-1/2"	3-1/2" X 3-1/2"	2-1/2" X 2-1/2"	1-1/4"	1-1/2" X 1-5/16"	1-5/8" X 1-1/4"	1-3/4" X 1-1/4"	1-3/4" X 1-1/4"

**NOTES:**

1. THE ABOVE TABLE SHOWS EXAMPLES OF POST AND BRACE SECTIONS WHICH MAY COMPLY WITH THE SPECIFICATIONS.
2. SECTIONS SHOWN IN THE TABLES MUST ALSO COMPLY WITH THE STRENGTH REQUIREMENTS AND OTHER PROVISIONS OF THE SPECIFICATIONS.
3. OTHER SECTIONS WHICH COMPLY WITH THE STRENGTH REQUIREMENTS AND OTHER PROVISIONS OF THE SPECIFICATIONS MAY BE USED ON APPROVAL OF THE ENGINEER.
4. OPTIONS EXERCISED SHALL BE UNIFORM ON ANY ONE PROJECT.
5. DIMENSIONS SHOWN ARE NOMINAL.
6. THE FABRIC SHALL BE ZINC COATED, ON. 9 GAGE WOVEN IN A 2" X 2" OR A 3-1/2" X 5-1/2" MESH, (FOR REDWOOD PICKETS).
7. PICKETS SHALL BE MADE OF STANDARD GRADE "A" STAINED REDWOOD PICKETS INSERTED VERTICALLY IN EACH MESH OF THE CHAIN LINK FABRIC (3-1/2" X 5-1/2").

GATE POST			
FENCE HEIGHT	GATE WIDTHS	NOMINAL ID	WEIGHT PER FOOT
6'-0" AND LESS	UP THRU 6' OVER 6'	2-1/2"	4.95
	THRU 12' OVER 12'	4"	10.79
	THRU 18' OVER 18'	5"	14.62
	TO 24' MAX.	6"	18.97
OVER 6'	UP THRU 6' OVER 6'	2-1/2"	4.95
	THRU 12' OVER 12'	4"	10.79
	THRU 18' OVER 18'	5"	14.62
	TO 24' MAX.	6"	18.97

ABOVE POST DIMENSIONS AND WEIGHTS ARE MINIMUMS. LARGER SIZES MAY BE USED WITH APPROVAL OF ENGINEER.

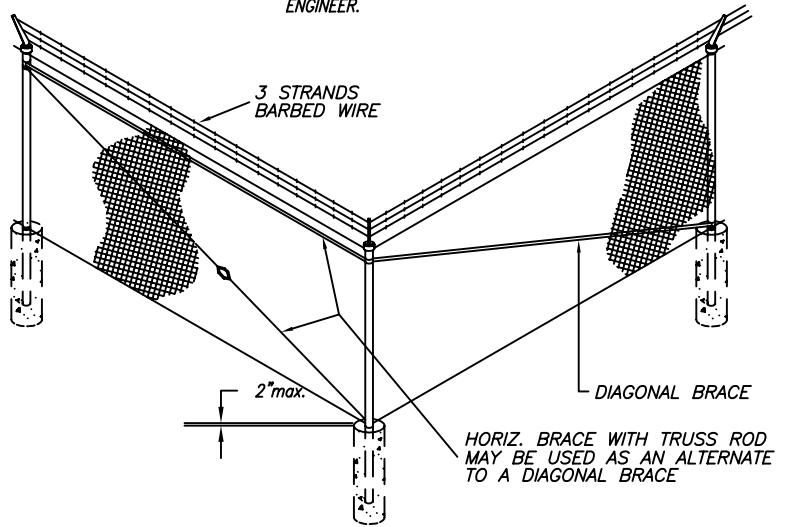
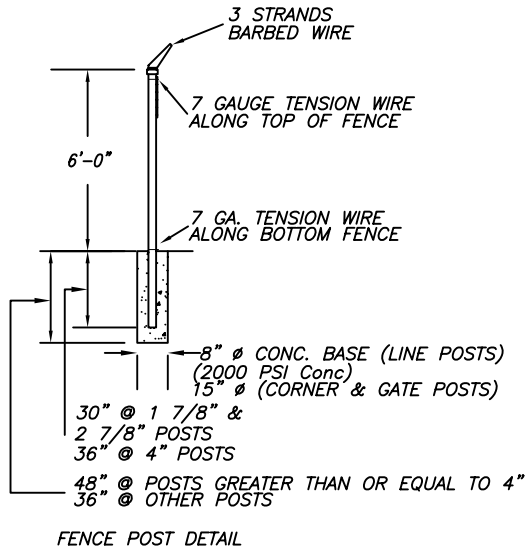

BRACE TO BE REMOVED AFTER ALL OTHER FENCE CONSTRUCTION IS COMPLETED UNLESS OTHERWISE DIRECTED BY THE ENGINEER

HORIZ. BRACE W/ 3/8" DIA. TRUSS RODS

1 5/8" O.D. HORIZ. PIPE W/ 3/8" DIA. TRUSS ROD PROVIDE @ EA. SIDE OF GATES AND @ EA. CORNER

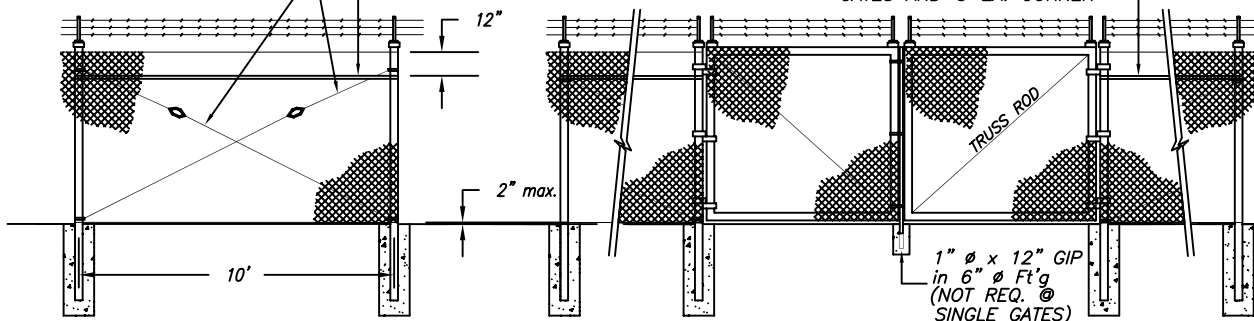

LINE POSTS @ 500' MAX. INTERVALS BRACED & TRUSSED IN BOTH DIRECTIONS

GATE DETAIL

NO.	REVISED	BY
DRAWN BY: TP		
CHECKED BY: DJR		
SCALE: NONE		

**Chain Link Fence Standards**

**CITY OF RIPON**

APPROVED
CITY ENGINEER RCE-28191
DATE: 2-2-99
STANDARD NO. <b>M-14</b>



## PARKING NOTES

1. *The minimum thickness after full compaction in traveled areas shall be 2-1/2" asphalt concrete over 4" aggregate base and in parking areas shall be 2-1/2" asphalt concrete over compacted native ground. (Parking lots for trucks and/or unusual traffic shall be designed accordingly).*
2. *Under sidewalk drains shall be allowed for parking areas up to 1/2 acre in size. Larger parcels must connect to a storm drain in the adjacent street.*
3. *A minimum cross slope of 1-1/2% is required for pavement.*
4. *A minimum of 0.33% is required for concrete gutter slope.*
5. *All curbs shall be 6" high.*
6. *Parking layout and design shall be in conformance with the off-street parking standards.*
7. *All parking stall lines shall be delineated with white traffic paint.*
8. *Any parking layout necessitating a cul-de-sac, or similar type of turning facility, for reversing the direction of travel will generally be discouraged, and shall be approved by the City Staff prior to incorporation into the plan.*
9. *Parking or backing areas within a parking lot shall not extend into the public right-of-way.*
10. *In all parking lot designs, provisions shall be made for the maneuvering of emergency and garbage collection vehicles.*
11. *All planters shall be landscaped and have an irrigation system.*
12. *Concrete curbing shall be used as wheel stops where possible. The use of bumper blocks is discouraged.*
13. *Handicapped stalls shall comply with the State Building Code / ADA and the City of Ripon Standards.*
14. *Dead-end 90° parking shall be provided with adequate turning room.*
15. *In locations where parallel parking is permitted or possible, an additional 3 feet shall be added to the aisle width to accommodate parked vehicles on both sides (i.e. parking on one side 28 feet, on both sides 36 feet). Parallel parking is considered possible wherever 20 feet or more of clear, reasonably straight curb exists.*
16. *Up to 20% of total stalls can be compact stalls (8-1/2' x 17'), for facilities with 20 or more stalls.*
17. *Dimensions for other parking angles must be evaluated separately for approval.*
18. *For two-way traffic, a minimum aisle width of 25' is required. For one-way traffic, a minimum aisle width of 13' is required.*
19. *The minimum number of parking spaces required is established by the Ripon Municipal Code.*
20. *All off-street parking designs shall have provisions for night lighting.*
21. *Directional arrows will be placed on pavement according to standards.*

NO.	REVISED	BY	<b>Off Street Parking Standards</b>	APPROVED
				
				CITY ENGINEER RCE-28191
				DATE: 2-2-99
DRAWN BY: Matt			<b>CITY OF RIPON</b>	STANDARD NO. <b>M-15</b>
CHECKED BY: DJR				
SCALE: NONE				

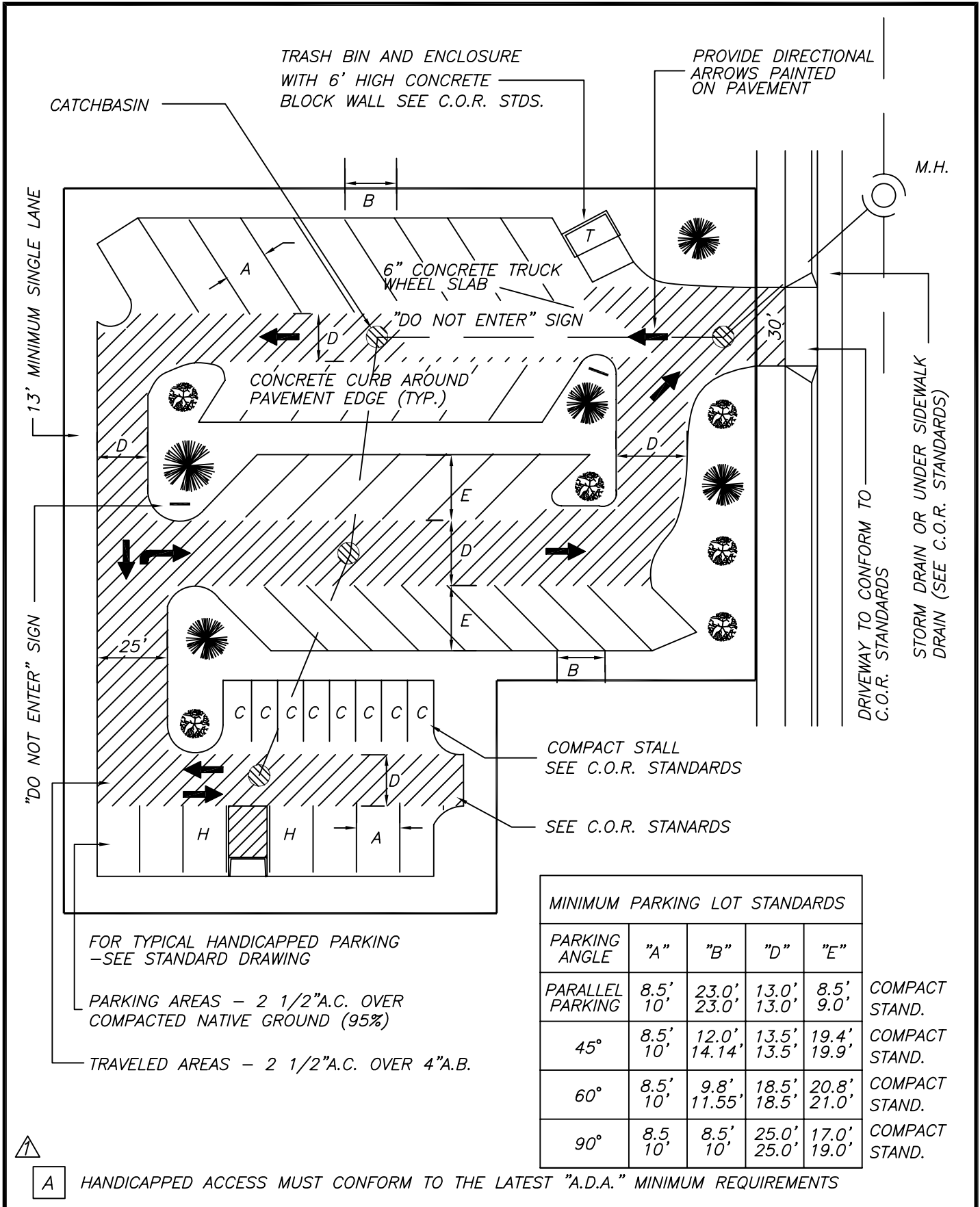

NO.	REVISED	BY	<b>Off Street Parking Standards</b>	APPROVED
▲	1-2003	MCP		<i>Matt MacCabe</i>
				CITY ENGINEER RCE-58093
DRAWN BY: MATT				DATE: 6-2002
CHECKED BY: DJR			<b>CITY OF RIPON</b>	STANDARD NO. <b>M-16</b>
SCALE: NONE				

**THIS PAGE  
INTENTIONALLY LEFT BLANK**

 1-2003 MCP

NO.	REVISED	BY		APPROVED
	1-2003	MCP		CITY ENGINEER RCE
				DATE: 1-2003
DRAWN BY:			<b>CITY OF RIPON</b>	STANDARD NO. <b>M-17</b>
CHECKED BY:				
SCALE:	NONE			

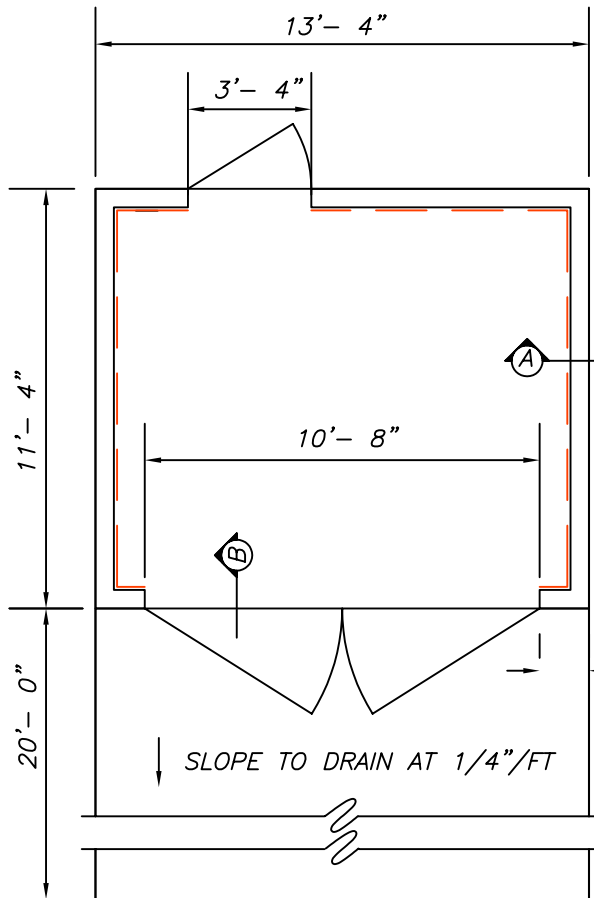

CONCRETE APRON  
PLAN VIEW

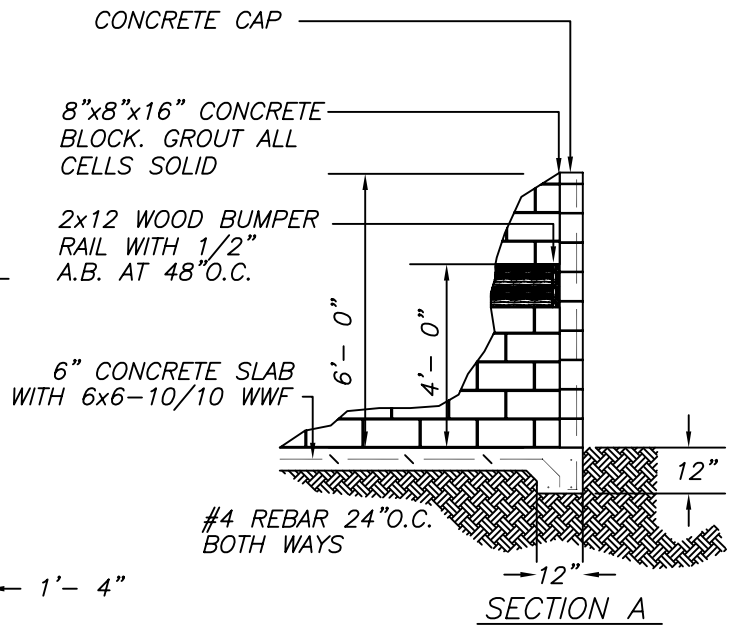

SECTION A

DOUBLE SWING GATE WITH REDWOOD SLATS

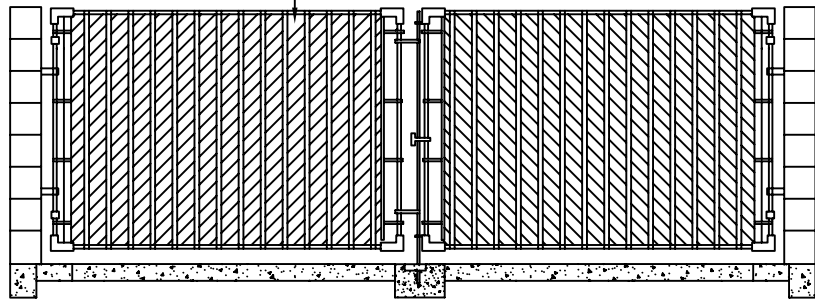

DOUBLE SWING GATE WITH REDWOOD SLATS

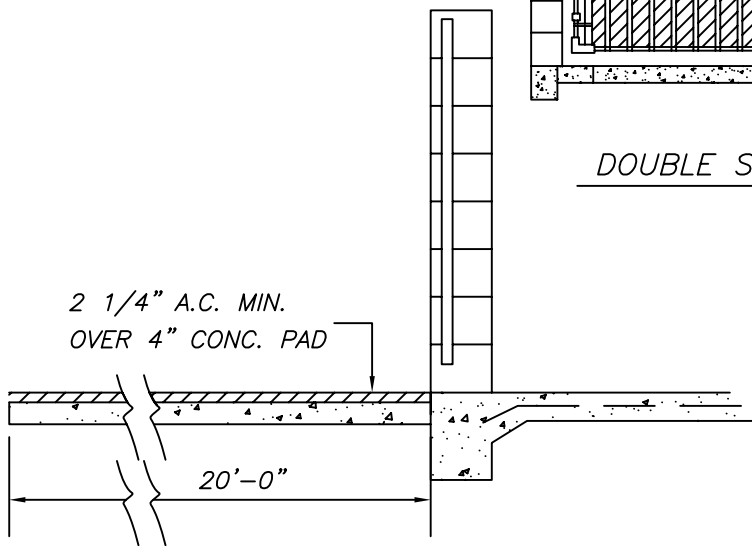

SECTION B

NO.	REVISED	BY	<b>10' x 12' Concrete Block Refuse Container Enclosure</b>	APPROVED  CITY ENGINEER RCE-28191
				DATE: 2-2-99
DRAWN BY: MATT				STANDARD NO. <b>M-18</b>
CHECKED BY: DJR			<b>CITY OF RIPON</b>	
SCALE: NONE				

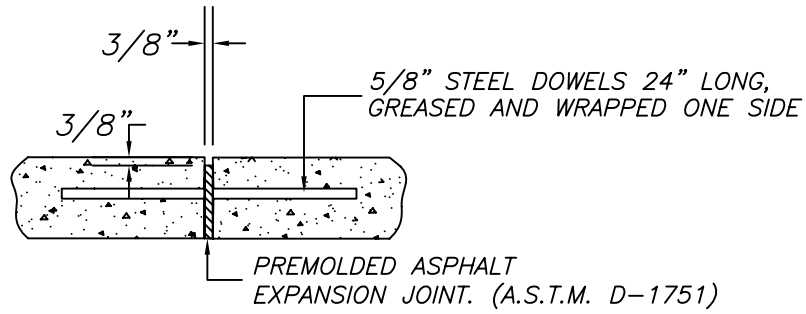

## EXPANSION JOINT

4'-2" WHEN PARALLEL WITH STREET  
6'-2" WHEN PERPENDICULAR TO STREET

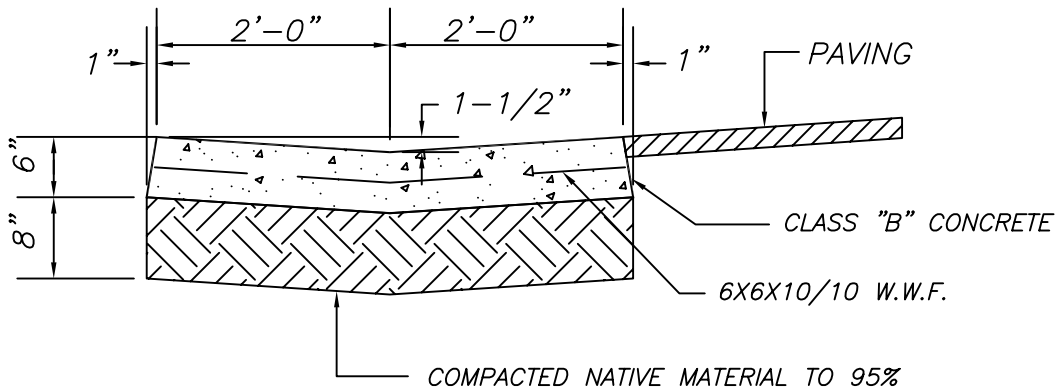

## CONCRETE VALLEY GUTTER

### NOTES

1. CONSTRUCT EXPANSION JOINTS AT 200 FEET CENTER TO CENTER, AT BEGINNING & ENDS OF CURBS, EACH SIDE OF CATCHBASINS AND OTHER FIXED OBJECTS.
2. CONCRETE VALLEY GUTTER TO BE USED ONLY WITH SPECIFIC APPROVAL OF THE CITY ENGINEER.
3. SEE NOTES ON CONCRETE CONSTRUCTION C.O.R. STDS.
4. MIN. FALL OF GUTTER SHALL BE SET BY CITY ENGINEER.

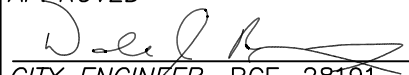
NO.	REVISED	BY	<b>Typical Expansion Joint and Valley Gutter</b>	APPROVED
▲	1-2003	MJM		 CITY ENGINEER RCE-28191
DRAWN BY: MCP				DATE: 2-2-99
CHECKED BY: DJR			<b>CITY OF RIPON</b>	STANDARD NO. <b>M-19</b>
SCALE: NONE				

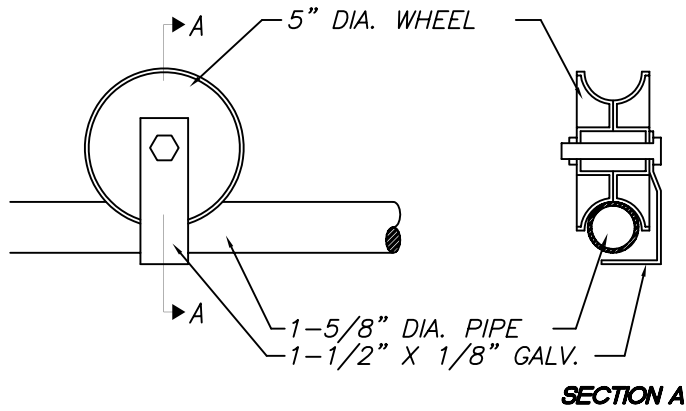

**GATE TO FENCE ROLLER**

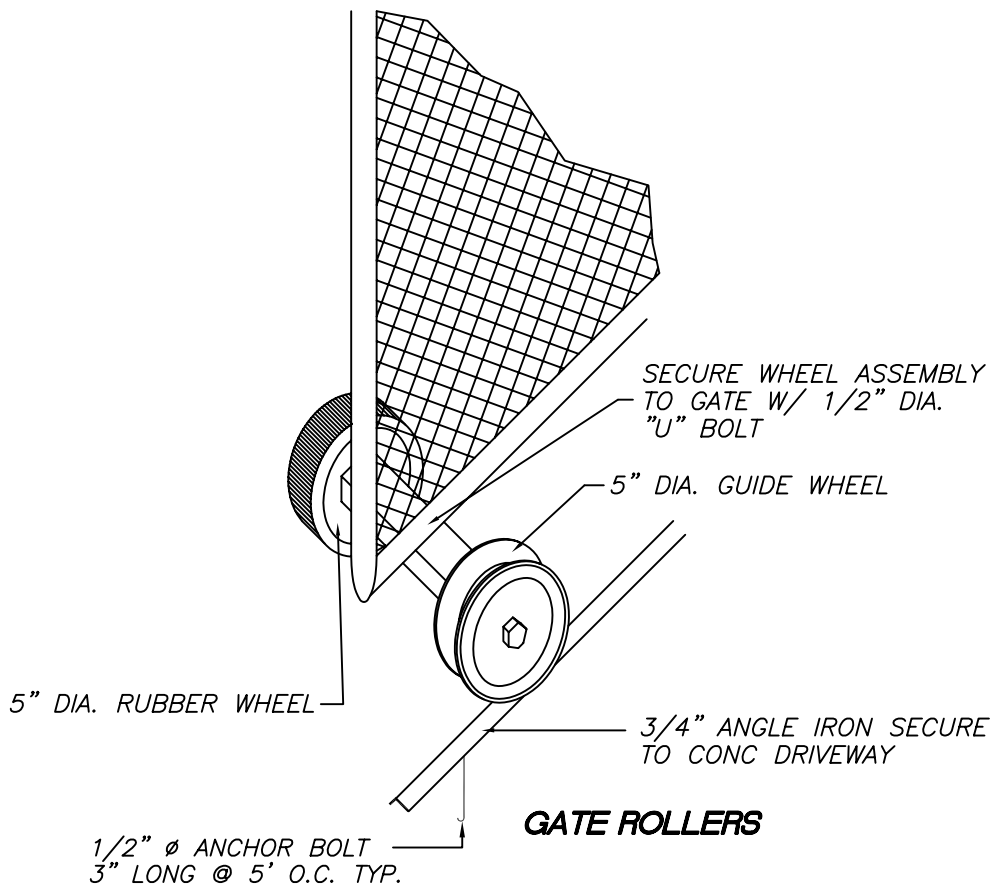

NO.	REVISED	BY	<b>Gate Rollers Detail</b>	APPROVED	
				<i>Dale B.</i>	CITY ENGINEER RCE-28191
				DATE: 2-2-99	
DRAWN BY: MCP			<b>CITY OF RIPON</b>	STANDARD NO. <b>M-20</b>	
CHECKED BY: DJR					
SCALE: NONE					

NOTES:

1. UNDER WATER QUALITY ORDER 99-08-DWQ, IT IS THE OWNER/DEVELOPER'S RESPONSIBILITY TO COMPLY WITH THE STATE OF CALIFORNIA NPDES REGULATIONS.
2. THESE PLANS FOR SEDIMENT AND EROSION CONTROL MEASURES, TO BE USED, AND SHOWN ON SAID PLANS WILL BE INSTALLED UPON PROJECT COMMENCEMENT AND MAINTAINED IN OPERABLE CONDITION AT ALL TIMES.
3. EQUIPMENT AND WORKERS FOR EMERGENCY WORK SHALL BE MADE AVAILABLE AT ALL TIMES DURING THE RAINY SEASON. ALL NECESSARY MATERIALS SHALL BE STOCKPILED ON SITE AT CONVENIENT LOCATIONS TO FACILITATE RAPID CONSTRUCTION OF TEMPORARY DEVICES WHEN RAIN IS IMMINENT.
4. DEVICES SHOWN ON PLANS SHALL NOT BE MOVED OR MODIFIED WITHOUT THE APPROVAL OF THE CITY INSPECTOR.
5. THE CONTRACTOR SHALL HAVE ALL EROSION/SEDIMENT CONTROL DEVICES TO WORKING ORDER TO THE SATISFACTION OF THE CITY INSPECTOR PRIOR TO EACH RUN-OFF PRODUCING RAINFALL.
6. THE CONTRACTOR SHALL INSTALL ADDITIONAL EROSION CONTROL MEASURES AS MAY BE REQUIRED BY THE CITY INSPECTOR DUE TO UNCOMPLETED GRADING OPERATIONS OR UNFORESEEN CIRCUMSTANCES WHICH MAY ARISE.
7. THE CONTRACTOR SHALL BE RESPONSIBLE AND SHALL TAKE NECESSARY PRECAUTIONS TO PREVENT PUBLIC TRESPASS ONTO AREAS WHERE IMPOUNDED WATERS CREATE A HAZARDOUS CONDITION.
8. ALL EROSION CONTROL MEASURES PROVIDED PER THE APPROVED GRADING PLAN SHALL BE INCORPORATED HEREON.
9. GRADED AREAS AROUND THE PROJECT PERIMETER MUST BE DRAINED AWAY FROM THE FACE OF SLOPE AT THE CONCLUSION OF EACH WORKING DAY.
10. ALL SEDIMENT REMOVAL DEVICES SHOWN SHALL BE IN PLACE AT THE END OF EACH WORKING DAY WHEN THE FIVE-DAY RAIN PROBABILITY FORECAST EXCEEDS 40%.
11. FOR CITY PROJECTS, THE CITY WILL PREPARE A STORM WATER POLLUTION PREVENTION PLAN (SWPPP) FOR THE PROJECT. THE SWPPP WILL INCLUDE CONSIDERATION OF STORM WATER BEST MANAGEMENT PRACTICES WHICH SHOULD BE INCORPORATED INTO THE PROJECT DESIGN AS WELL AS MEASURES WHICH WILL BE IMPLEMENTED DURING THE ONGOING USE OF THE PROPOSED PROJECT IN ORDER TO MINIMIZE URBAN RUNOFF OR OTHER CONTAMINATION.
12. FOR CITY PROJECTS, THE CITY WILL FILE A NOTICE OF INTENT WITH THE REGIONAL WATER QUALITY BOARD.

NO.	REVISED	BY	<b>GENERAL STORM WATER POLLUTION PREVENTION NOTES</b>	APPROVED
				
				CITY ENGINEER 58093
				DATE: 12-12-06
DRAWN BY: AJM			<b>CITY OF RIPON</b>	STANDARD NO. <b>SWPP-1</b>
CHECKED BY: CPB				
SCALE: NONE				

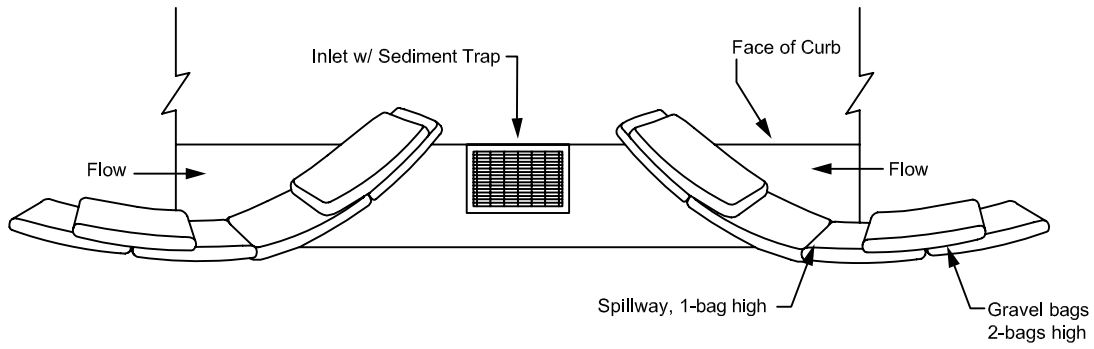

**TYPICAL PROTECTION FOR INLET ON SUMP**

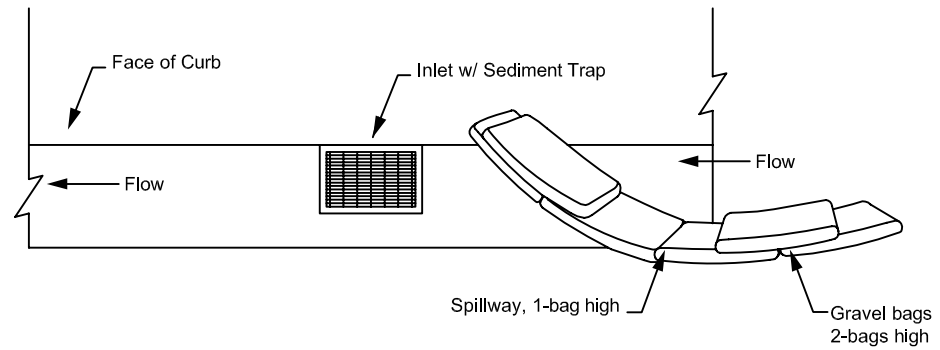

**TYPICAL PROTECTION FOR INLET ON GRADE**

**NOTES:**

1. Intended for short-term use.
2. Use to inhibit non-storm water flow.
3. Allow for proper maintenance and cleanup.
4. Bags must be removed after adjacent operation is completed.
5. Not applicable in areas with high silts and clays without filter fabric.
6. Gravel bags must be accompanied by an inlet sediment trap w/ trash guard.  
The sediment bag shall be cleaned out regularly and after runoff generating rainfall events.

NO.	REVISED	BY	<b>STORM DRAIN INLET PROTECTION</b>	APPROVED	 <b>CITY ENGINEER 58093</b> DATE: 12-12-06 STANDARD NO. <b>SWPP-2</b>
DRAWN BY: AJM			<b>CITY OF RIPON</b>		
CHECKED BY: CPB					
SCALE: NONE					



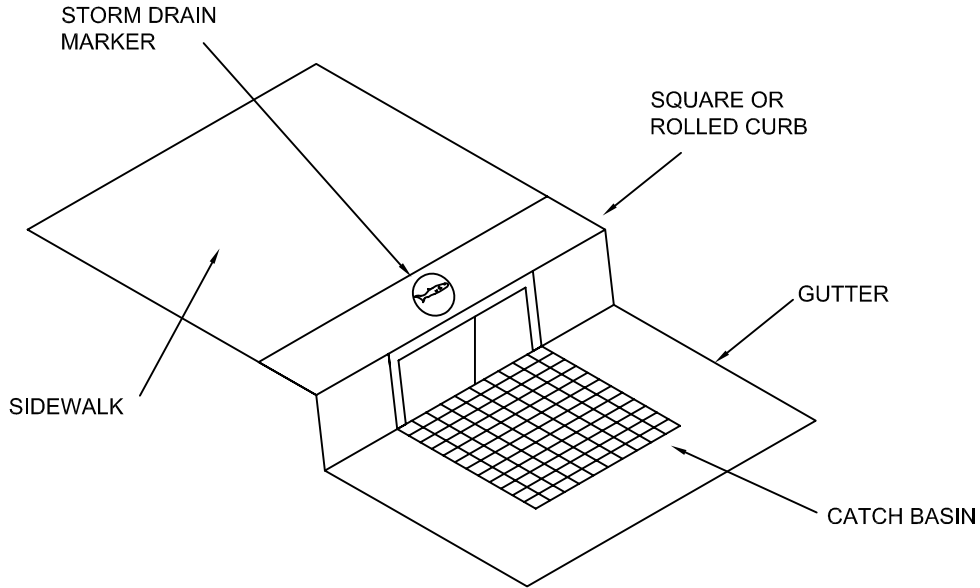

**NOTES:**

1. ALL STORM DRAIN CATCH BASINS SHALL HAVE A STORM DRAIN MARKER INSTALLED PRIOR TO PROJECT COMPLETION. THE MARKER SHALL BE CENTERED ON THE CURB BEHIND THE CATCH BASIN.

2. THE STORM DRAIN MARKERS SHALL BE ALMETEK STORM DRAIN MARKERS. THE MARKER SHALL BE ITEM No. SD-10, STAINLESS STEEL, BLUE, WITH "NO DUMPING, DRAINS TO RIVER" EMBOSSED ON THE MARKER, WITH FISH SYMBOL AND "CITY OF RIPON" SERIALIZATION INCLUDED ON THE MARKER. THE MARKER SHALL HAVE THE SQUARE CENTER HOLE FOR SUB-SURFACE MOUNT INSTALLATION WITH DRIVE RIVET.

3. THE STORM DRAIN MARKERS CAN BE PURCHASED FROM ALMETEK INDUSTRIES, INC. - (908) 850-9700, WWW.ALMETEK.COM

NO.	REVISED	BY	<b>STORM DRAIN MARKER</b>	APPROVED
				
				CITY ENGINEER 58093
DRAWN BY: AJM				DATE: 12-12-06
CHECKED BY: CPB			<b>CITY OF RIPON</b>	STANDARD NO. <b>SWPP-3</b>
SCALE: NONE				

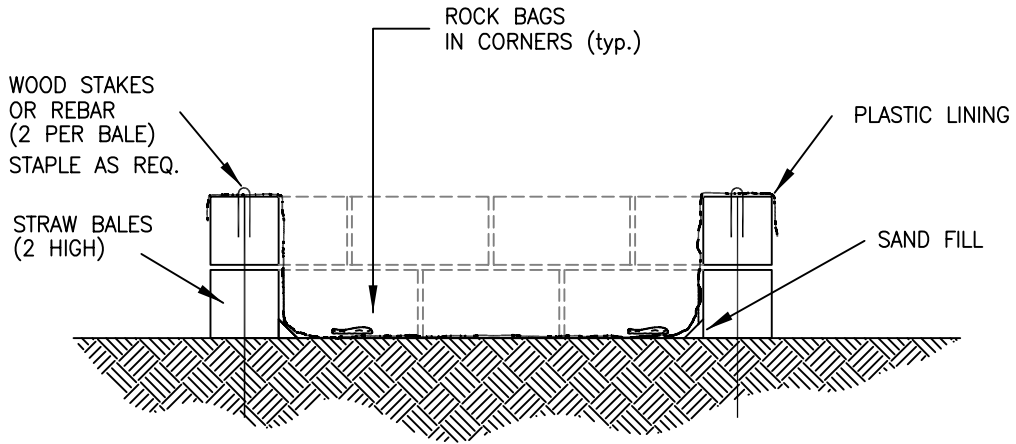

SECTION VIEW

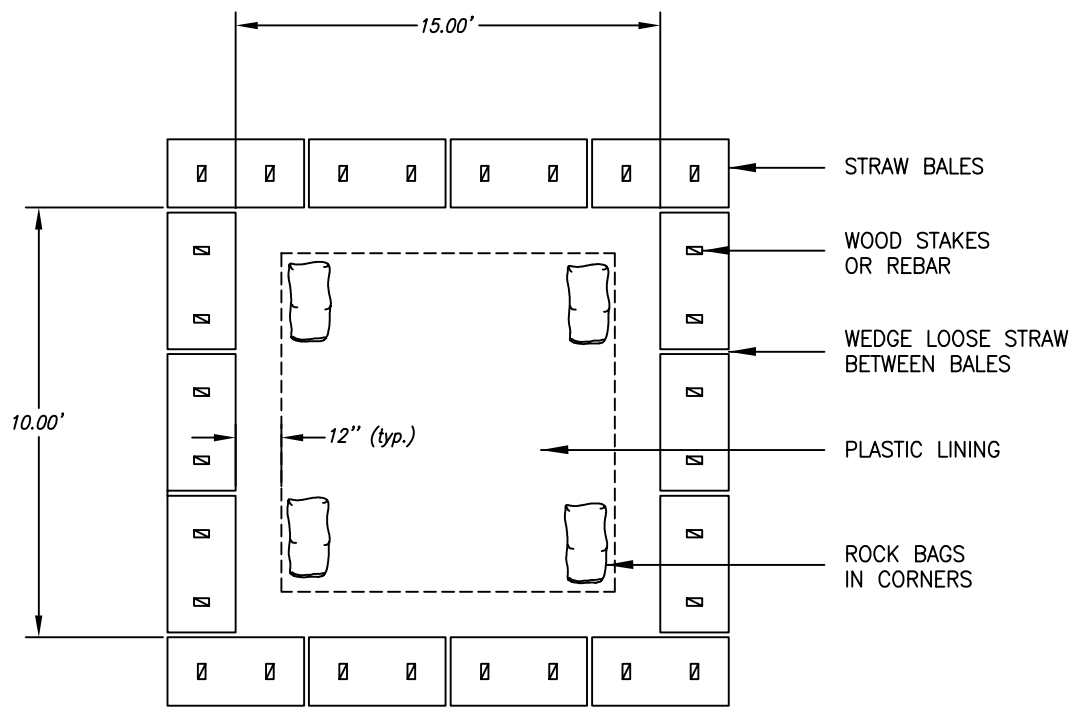

PLAN VIEW

- NOTES:**
1. ALL CONCRETE WASHOUT FACILITIES SHALL BE CLEANED OUT REGULARLY TO AVOID SPILLAGE OF CONCRETE OUTSIDE OF WASHOUT.
  2. ALL WASHOUTS SHALL BE REPAIRED AND MAINTAINED REGULARLY.

NO.	REVISED	BY	<b>ON GRADE TEMPORARY CONCRETE WASHOUT FACILITY</b>	APPROVED	 CITY ENGINEER 58093
				DATE: 12-12-06	
				STANDARD NO. <b>SWPP-4A</b>	
DRAWN BY: AJM			<b>CITY OF RIPON</b>		
CHECKED BY: CPB					
SCALE: NONE					

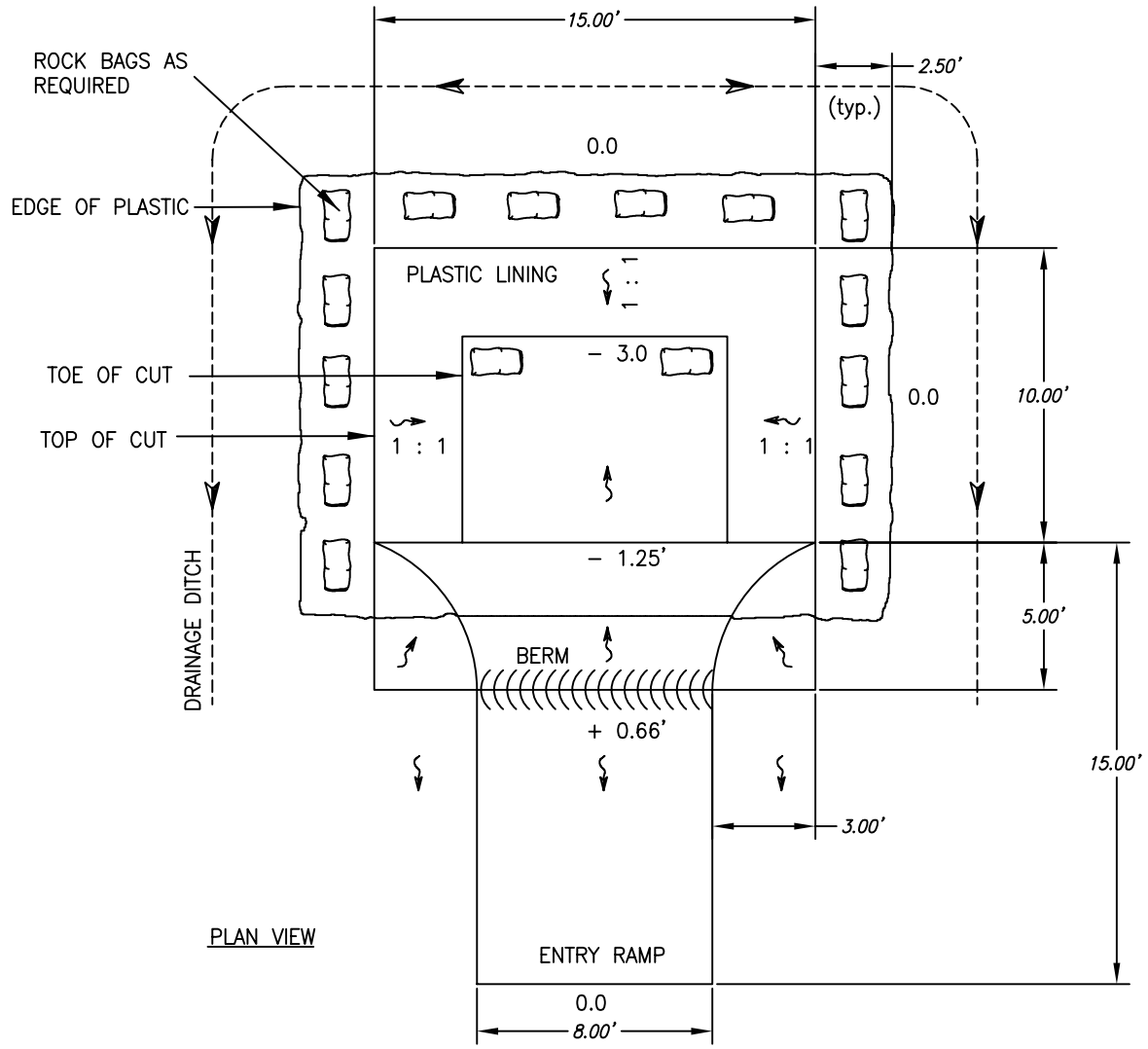
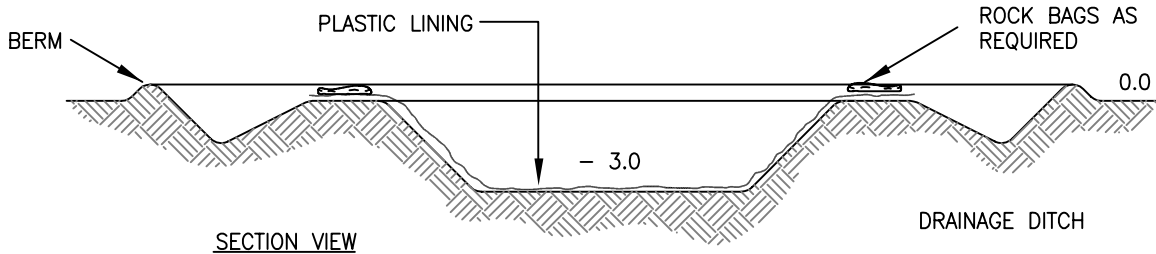

SCALE: NONE

NO.	REVISED	BY
DRAWN BY: AJM		
CHECKED BY: CPB		
SCALE: NONE		

**BELOW GRADE  
TEMPORARY CONCRETE  
WASHOUT FACILITY**

**CITY OF RIPON**

APPROVED
<i>Matt MacDade</i>
CITY ENGINEER 58093
DATE: 12-12-06
STANDARD NO. <b>SWPP-4B</b>

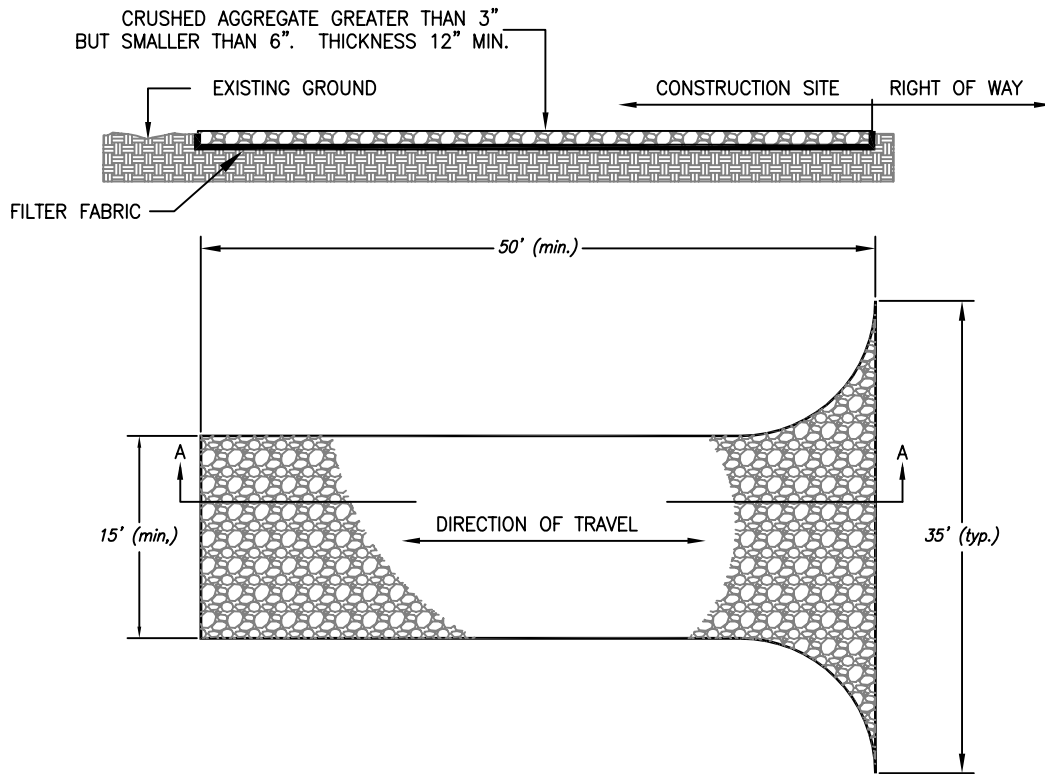

**NOTES:**

1. STABILIZED CONSTRUCTION SITE ACCESS SHALL BE CONSTRUCTED OF 3" MIN. CRUSHED ROCK, MATERIAL SHALL BE PLACED TO A MINIMUM THICKNESS OF 12 INCHES. THE ROCK ENTRANCE SHALL BE UNDERLINED WITH FILTER FABRIC, TO ELIMINATE ROCK BEING PUSHED INTO THE SOIL, AND THE SOIL PUMPING UP INTO THE ROCK BED.
2. LENGTH TO ENTRANCE SHALL BE A MINIMUM OF 50 FEET. WIDTH SHALL BE A MINIMUM OF 15 FT. OR GREATER IF NECESSARY TO COVER ALL VEHICULAR INGRESS AND EGRESS. PROVIDE AMPLE TURNING RADII.
3. THE ENTRANCE SHALL BE KEPT IN GOOD CONDITION BY OCCASIONAL TOP DRESSING WITH MATERIAL AS SPECIFIED IN NOTE 1.
4. ACCESSSES SHALL BE INSPECTED WEEKLY DURING PERIODS OF HEAVY USAGE, MONTHLY DURING NOMAL USAGE, AND AFTER EACH RAINFALL, WITH MAINTENANCE PROVIDED AS NECESSARY. PERIODIC TOP DRESSING SHALL BE DONE AS NEEDED.

NO.	REVISED	BY	<b>STABILIZED CONSTRUCTION ENTRANCE</b>	APPROVED
				 CITY ENGINEER 58093
DRAWN BY: AJM				DATE: 12-12-06
CHECKED BY: CPB				<b>CITY OF RIPON</b>
SCALE: NONE			STANDARD NO. <b>SWPP-5</b>	

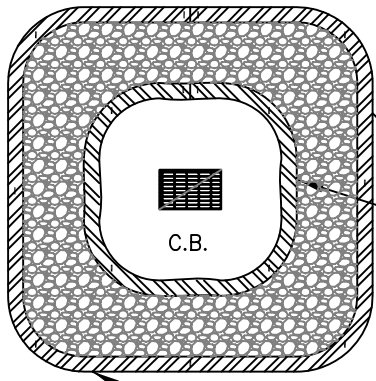

C.B.

FIBER ROLL

NOTES:  
 A SINGLE RING OF PROTECTION  
 USED WHEN CB/DI/INLET OR MANHOLE  
 IS ON AN EXISTING HARD SURFACE, E.G.  
 ROAD , CONCRETE ECT.; A DOUBLE RING  
 OF PROTECTION SHALL BE USED WHEN  
 CB/DI/MANHOLE IS LOCATED AND  
 SURROUNDED BY EXISTING LOOSE  
 GROUND/ EARTH.

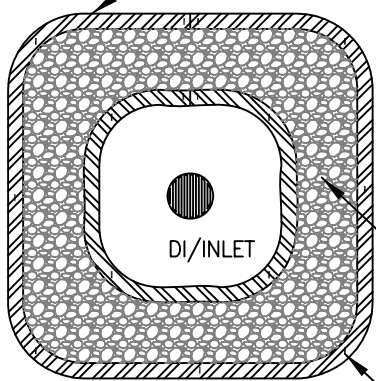

DI/INLET

2" THK 3/4" A.B. (typ.)

SEE NOTES  
 BELOW (TYP.)

STAKES PLACED AT CORNERS  
 AND ENDS TO HOLD IN PLACE  
 ON EXISTING GROUND.

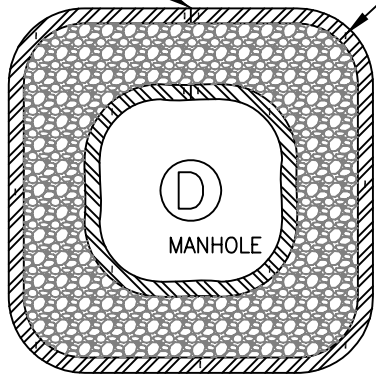

MANHOLE

NOTES: FOLLOW MANUFACTURES SPECS ON JOINING AND APPLYING FIBER ROLLS,  
 OTHERWISE USE THE ABOVE GUIDELINES. ENDS SHALL BE ABUTTED TOGETHER  
 RATHER THEN OVERLAPPED.

SCALE: NONE

NO.	REVISED	BY	<b>FIELD INLET / MANHOLE PROTECTION</b>	APPROVED
				
				CITY ENGINEER 58093
DRAWN BY: AJM				DATE: 12-12-06
CHECKED BY:			<b>CITY OF RIPON</b>	STANDARD NO. <b>SWPP-6</b>
SCALE: NONE				